

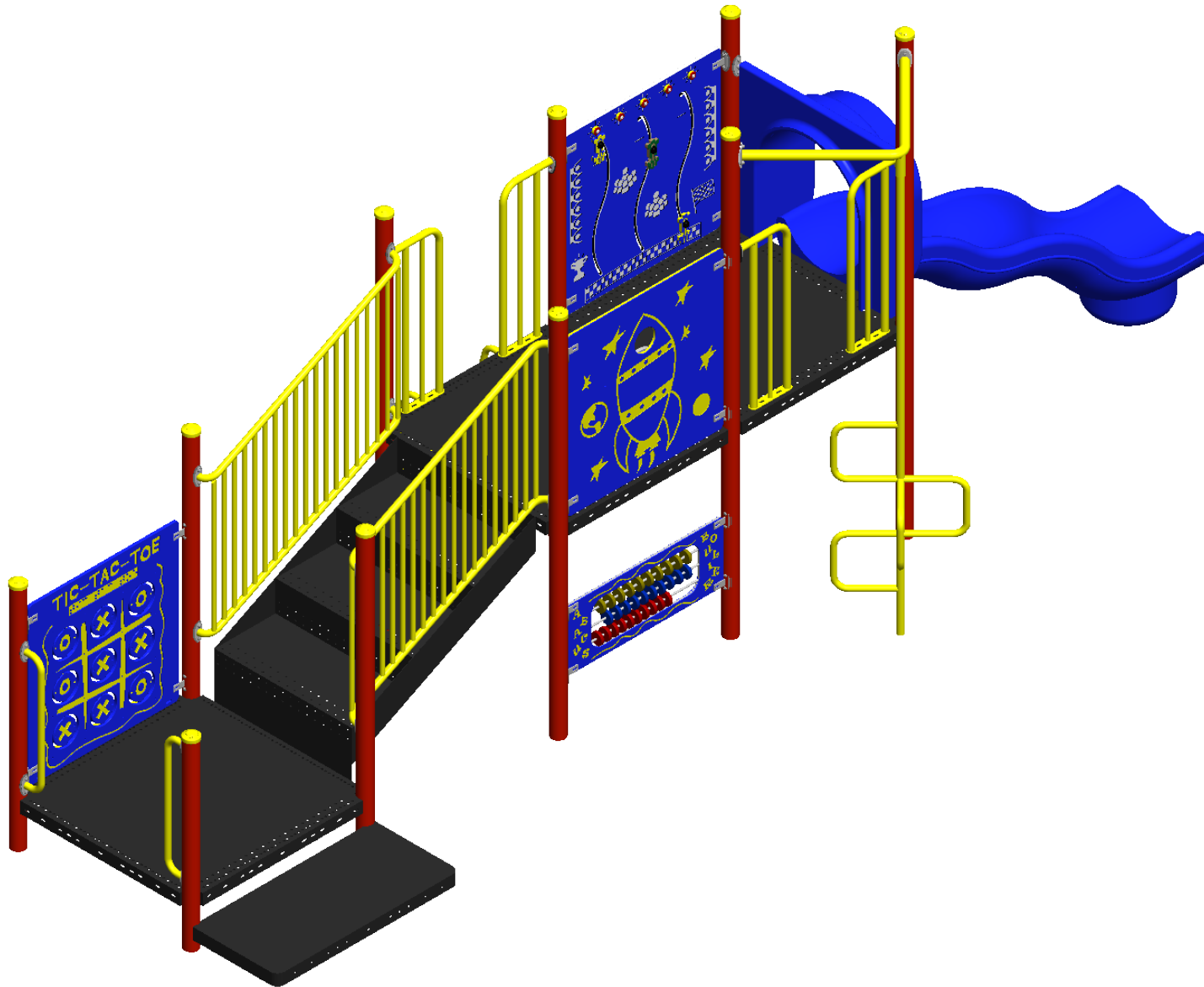

23 ch. Boom Lane, Unit/Unité E Industrial
Park/Parc industriel Atholville, New/Nouveau-
Brunswick Canada, E3N 4E8
Tel/tél. : 1-888-212-1411/Fax/télec. : 1-888-
789-0987 www.kangaroo.com



kroll-187M1

Min. Protective Surface Required / Surface de protection min. requise
10.8 m (35'-6") x 6.0m (19'-9")

Equipment Dimensions / Dimensions de l'équipement :
7.2m (23'-9") x 3.2m (10'-7")

Approval date: 2021-01-12

Rev: 00

CAN/CSA-Z614

Recommended Ages / Âges recommandés :
5Years to 12 Years old / 5 Ans à 12 Ans

Capacity / Peut accueillir : up to 20 children / Jusqu'à 20 enfants

Initial: A.K



23 ch. Boom Lane, Unit/Unité E Industrial
Park/Parc industriel Atholville, New/Nouveau-
Brunswick Canada, E3N 4E8
Tel/tél. : 1-888-212-1411/Fax/télé. : 1-888-
789-0987 www.kangaroo.com



kroll-187M1

Min. Protective Surface Required / Surface de protection min. requise
10.8 m (35'-6") x 6.0m (19'-9")

Equipment Dimensions / Dimensions de l'équipement :
7.2m (23'-9") x 3.2m (10'-7")

Approval date: 2021-01-12

Rev: 00

CAN/CSA-Z614

Recommended Ages / Âges recommandés :
5Years to 12 Years old / 5 Ans à 12 Ans

Capacity / Peut accueillir : up to 20 children / Jusqu'à 20 enfants

Initial: A.K



23 ch. Boom Lane, Unit/Unité E Industrial
 Park/Parc industriel Atholville, New/Nouveau-
 Brunswick Canada, E3N 4E8
 Tel/tél. : 1-888-212-1411/Fax/télé. : 1-888-
 789-0987 www.kangoroo.com

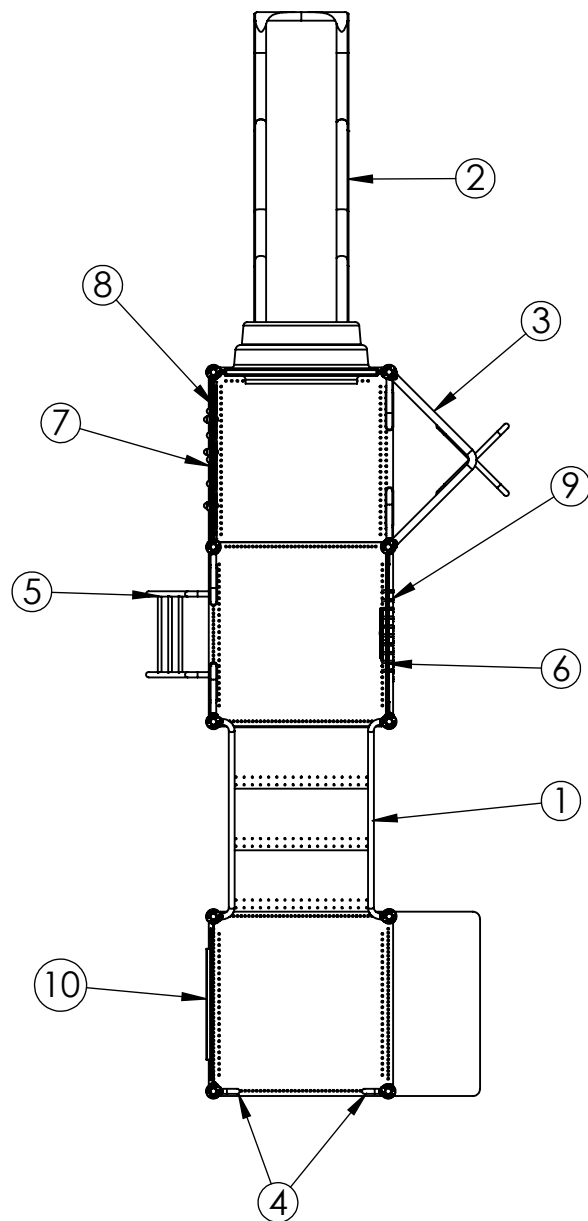

ITEM NO.	PART NUMBER	DESCRIPTION	QTY.
1	TRANST-48	TRANSFER STATION-48	1
2	FS-4DWWS	WAVY DOUBLE SLIDE 48	1
3	FS-CR-SNK-PL-48	CROSS SNAKE POLE 48	1
4	R10P	TRANSFER SUPPORT	2
5	CL-SH-48	INCLINER LADDER 48	1
6	KG-PLT	PILOT PANEL	1
7	KG-F1	KG-F1-W-POST_00	1
8	KG-AGEAR	ACCESSIBLE GEAR PANEL	1
9	KG-AABACUS	ACCESSIBLE AABACUS PANEL	1
10	KG-TTT	TIC-TAK-TOE PANEL	1

kroll-187M1

Min. Protective Surface Required / Surface de protection min. requise
 10.8 m (35'-6") x 6.0m (19'-9")

Equipment Dimensions / Dimensions de l'équipement :
 7.2m (23'-9) x 3.2m (10'-7")

Approval date: 2021-01-12

Rev: 00

Initial: A.K

CAN/CSA-Z614

Recommended Ages / Âges recommandés :
 5Years to 12 Years old / 5 Ans à 12 Ans

Capacity / Peut accueillir : up to 20 children / Jusqu'à 20 enfants





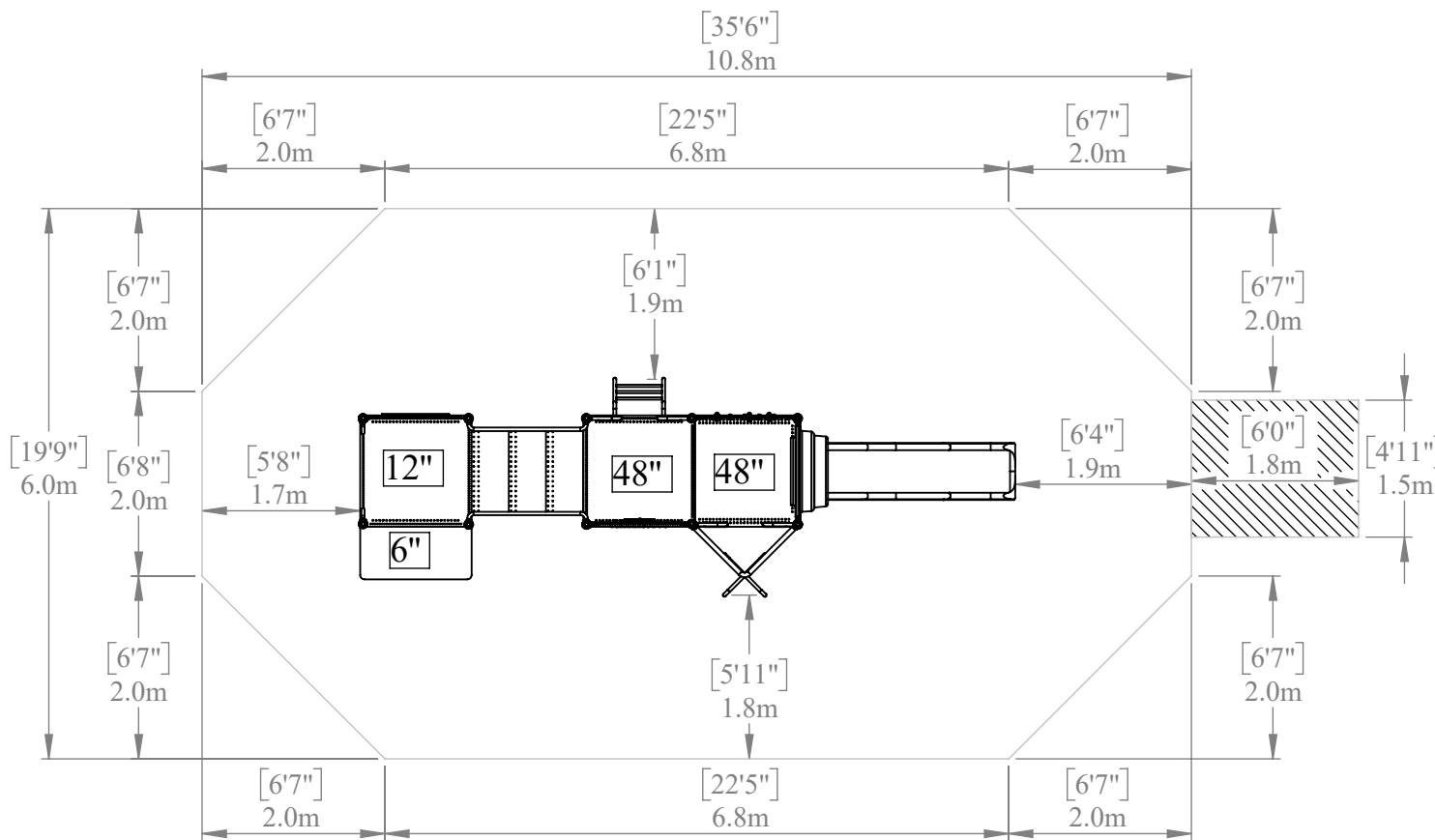

23 ch. Boom Lane, Unit/Unité E Industrial Park/Parc industriel
 Atholville, New/Nouveau-Brunswick Canada, E3N 4E8
 Tel/tél. : 1-888-212-1411/Fax/télé. : 1-888-789-0987
 www.kangoroo.com

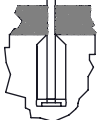

PLATFORM HEIGHTS
 HAUTEURS DE PLATEFORME

12" = 305MM	24" = 609MM
36" = 915MM	48" = 1219MM
60" = 1524MM	72" = 1829MM
84" = 2134MM	96" = 2438MM



<p>ZONE DE PROTECTION: Chaque équipement doit avoir une zone de protection constituée d'une surface sans obstacle qui se prolonge dans toutes les directions à partir du périmètre de l'équipement. Cette zone doit contenir un revêtement de surface (gravillon, sable, etc...) avec une capacité d'amortissement selon les normes CSA-Z614. Sauf avis contraire. Zone de protection minimum requise: 10.8m (35'-6") x 6.0m (22'-7") - Surface: 64.8 sq. m (697.5 sq. ft.) - Perimeter: 33.6 m (110'-2")</p>	<p>PROTECTIVE SURFACING ZONE : Each equipment shall have a protective surfacing zone that consist of obstacle-free surfacing surrounding the equipment. This zone shall contain shock absorbing material (pea gravel, sand, etc...) that comply with CSA-Z614. Unless noted otherwise. Minimum Protective Surfacing Zone required: 10.8m (35'-6") x 6.0m (22'-7") - Surface: 64.8 sq. m (697.5 sq. ft.) - Perimeter: 33.6 m (110'-2")</p>
<p>MÉTHODES D'INSTALLATION ① DANS LE BÉTON: - Quantité de Sonotube de 12" Ø x 12' : 3 Béton : - 1.2m.cu. (1.6vge.cu.)</p> 	<p>INSTALLATION METHODS ① CONCRETE -Quantity of sonotube of 12"Øx12':3 CONCRETE -1.2 cu.m. (1.6cu.yd.)</p> 
<p>② SYSTÈME AUTO-PORTANT: Qté charpentes: 6 Béton : - 0 m. cu. (0 vge cu.)</p> 	<p>② FREE-STANDING SYSTEM: Frame QTY: 6 Concrete: - 0 cu. m. (0 cu. yd.)</p> 
<p>Attention : AIRE DE CIRCULATION LIBRE: Aire dégagée d'obstacle qui se prolonge sur au moins 1.8m (70.87") au delà de la zone de protection. Voir dessin pour les détails.</p> 	<p>Warning: NO-ENCROACHMENT ZONE: Obstacle-free zone extending at least 1.8m (70.87") beyond the protective surfacing zone. See drawing for details.</p> 

<p>KROLL-187M1</p>	<p>Min. Protective Surface Required / Surface de protection min. requise 10.8m (35'-6") x 6.0m (19'-9")</p>	<p>Equipment Dimensions / Dimensions de l'équipement : 7.2 m (23'-9") x 3.2m (10'-7")</p>	<p>Fall Height / Hauteur de chute: 2.29 m (7'-6")</p>	<p>Approval date: 13-01-22 Rev: 00 Initial: AK</p>
<p>CAN/CSA-Z614</p>	<p>Recommended Ages / Âges recommandés : 5 Years to 12 Years old / 5 Ans à 12 Ans</p>	<p>Capacity / Peut accueillir : up to 20 children / Jusqu'à 20 enfants</p>		