

kpan-001

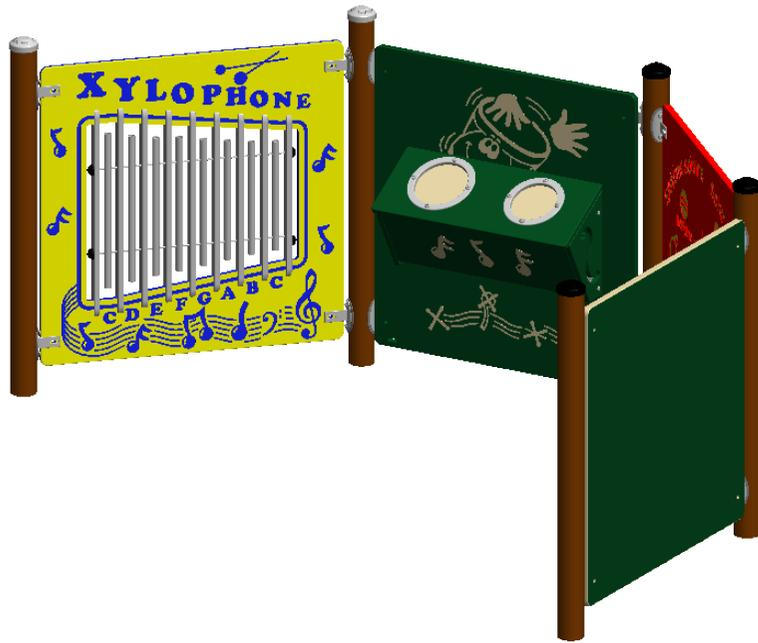

23 ch. Boom Lane, Unit/Unité E Industrial
 Park/Parc industriel Atholville, New/Nouveau-
 Brunswick Canada, E3N 4E8
 Tel/tél. : 1-888-212-1411/Fax/télé. : 1-888-
 789-0987 www.kangoroo.com



kpan-001

CAN/CSA-Z614

Min. Protective Surface Required / Surface de protection min. requise
 . m ("") x .m ("")

Recommended Ages / Âges recommandés :
 18 months to 12 years old / 18 mois à 12 ans

Equipment Dimensions / Dimensions de l'équipement :
 2.78m (9'-1.4") x 1.99m (6'-6.5")

Capacity / Peut accueillir : up to 15-20 children / Jusqu'à 15-20 enfants

Approval date: 2020-12-10

Rev: 00

Initial: S.T

kpan-001



23 ch. Boom Lane, Unit/Unité E Industrial
 Park/Parc industriel Atholville, New/Nouveau-
 Brunswick Canada, E3N 4E8
 Tel/tél. : 1-888-212-1411/Fax/télééc. : 1-888-
 789-0987 www.kangaroo.com

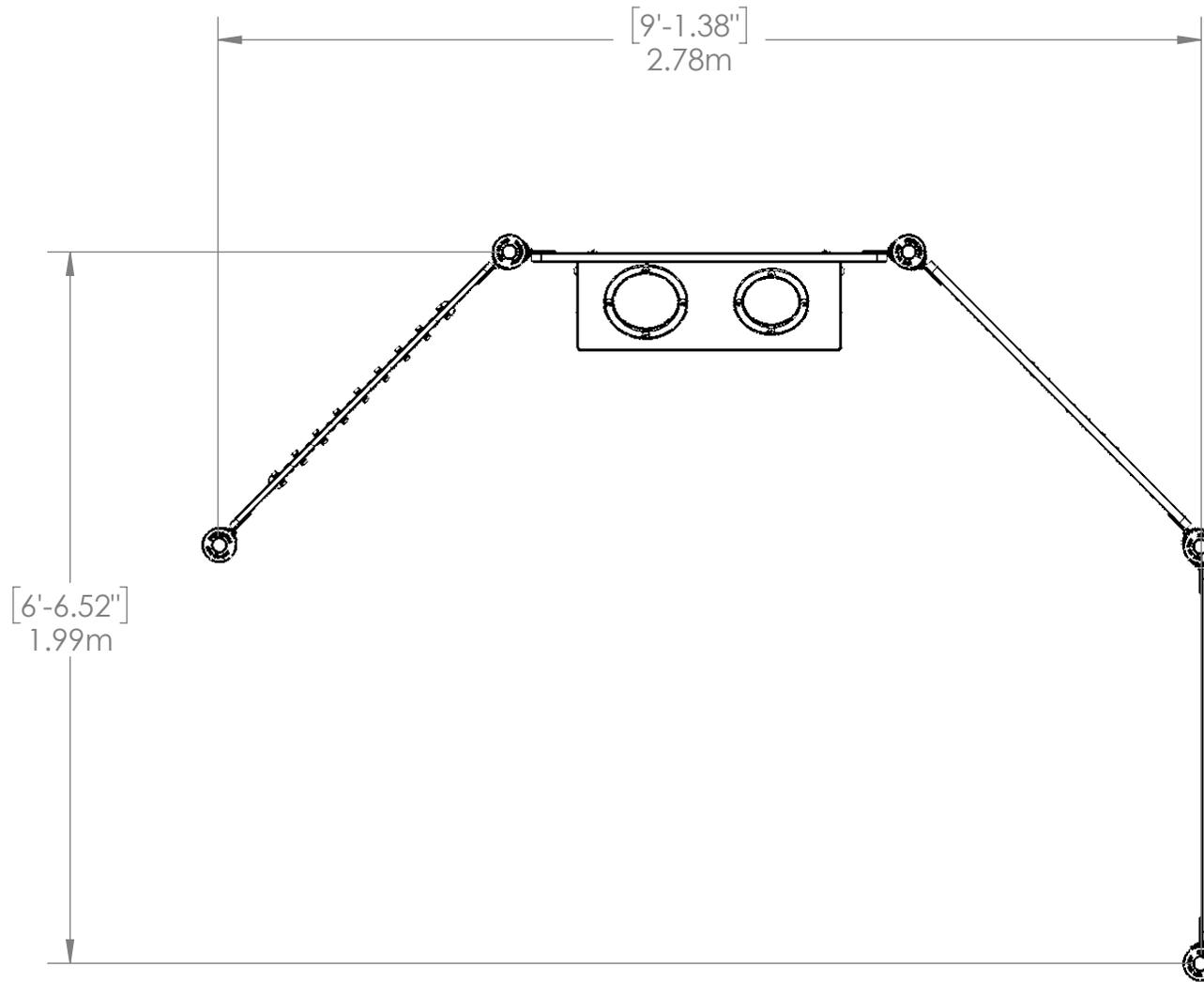

kpan-001	Min. Protective Surface Required / Surface de protection min. requise . m ("") x .m ("")	Equipment Dimensions / Dimensions de l'équipement : 2.78m (9'-1.4") x 1.99m (6'-6.5")	Approval date: 2020-12-10 Rev: 00
CAN/CSA-Z614	Recommended Ages / Âges recommandés : 18 months to 12 years old / 18 mois à 12 ans	Capacity / Peut accueillir : up to 15-20 children / Jusqu'à 15-20 enfants	Initial: S.T