



23 ch. Boom Lane, Unit/Unité E Industrial
 Park/Parc industriel Atholville, New/Nouveau-
 Brunswick Canada, E3N 4E8
 Tel/tél. : 1-888-212-1411/Fax/télec. : 1-888-
 789-0987 www.kangoroo.com



kkids-165

Min. Protective Surface Required / Surface de protection min. requise
 14.1. m (46'-1.6") x 9.3m (30'-7.3")

Equipment Dimensions / Dimensions de l'équipement :
 10.4m (34'-1.6") x 5.7m (18'-7.3")

Approval date: 2023-02-10

Rev: 00

CAN/CSA-Z614

Recommended Ages / Âges recommandés :
 18 months to 12 years old / 18 mois à 12 ans

Capacity / Peut accueillir : up to 30 children / Jusqu'à 30 enfants

Initial: S.T



23 ch. Boom Lane, Unit/Unité E Industrial
 Park/Parc industriel Atholville, New/Nouveau-
 Brunswick Canada, E3N 4E8
 Tel/tél. : 1-888-212-1411/Fax/télééc. : 1-888-
 789-0987 www.kangaroo.com



kkids-165

Min. Protective Surface Required / Surface de protection min. requise
 14.1. m (46'-1.6") x 9.3m (30'-7.3")

Equipment Dimensions / Dimensions de l'équipement :
 10.4m (34'-1.6") x 5.7m (18'-7.3")

Approval date: 2023-02-10

Rev: 00

CAN/CSA-Z614

Recommended Ages / Âges recommandés :
 18 months to 12 years old / 18 mois à 12 ans

Capacity / Peut accueillir : up to 30 children / Jusqu'à 30 enfants

Initial: S.T

23 ch. Boom Lane, Unit/Unité E Industrial Park/Parc industriel
 Atholville, New/Nouveau-Brunswick Canada, E3N 4E8
 Tel/tél. : 1-888-212-1411/Fax/télé. : 1-888-789-0987
 www.kangoroo.com

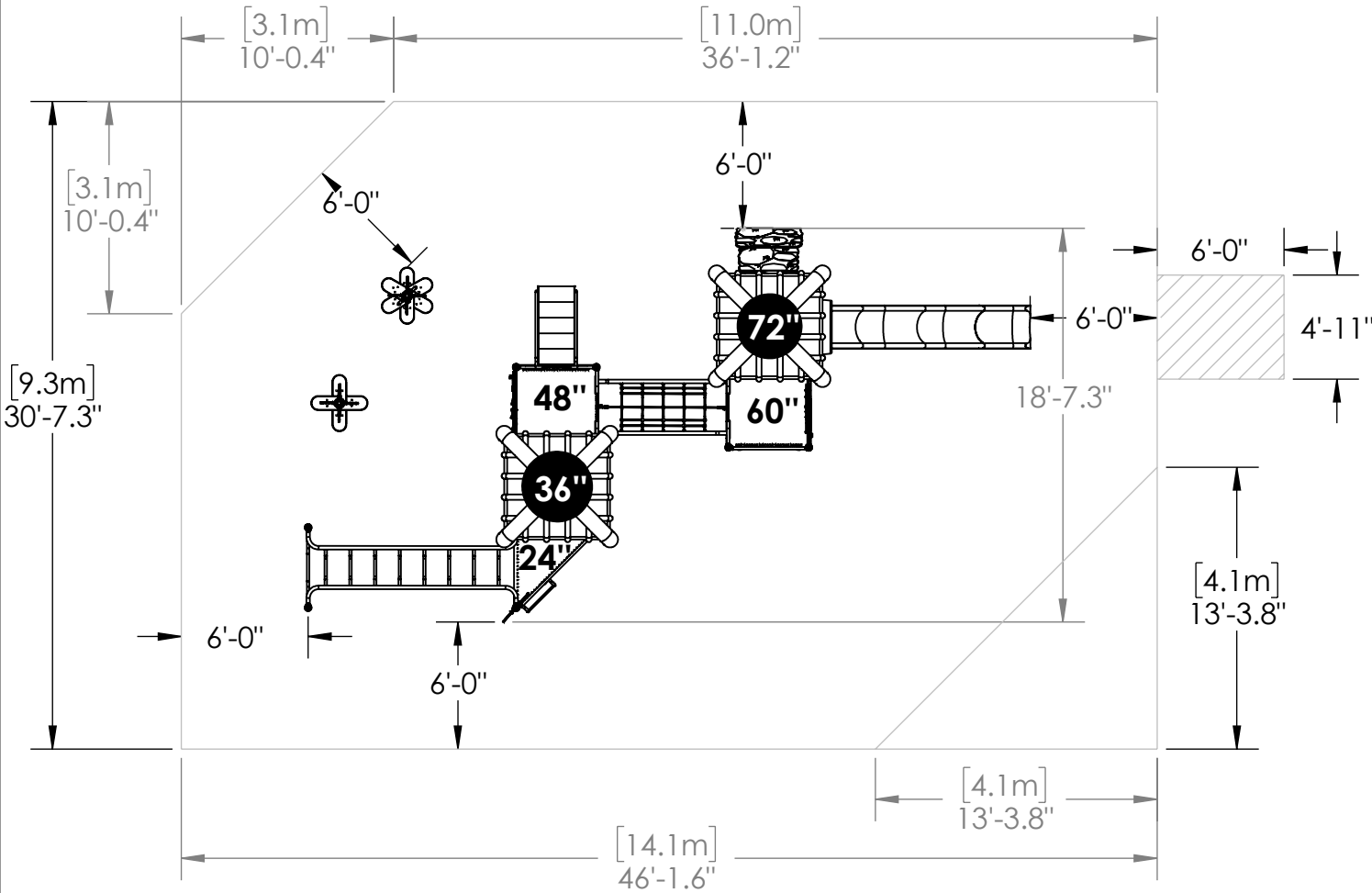

PLATFORM HEIGHTS
 HAUTEURS DE PLATEFORME
 12" = 305MM 24" = 609MM
 36" = 915MM 48" = 1219MM
 60" = 1524MM 72" = 1829MM
 84" = 2134MM 96" = 2438MM

ZONE DE PROTECTION:

Chaque équipement doit avoir une zone de protection constituée d'une surface sans obstacle qui se prolonge dans toutes les directions à partir du périmètre de l'équipement. Cette zone doit contenir un revêtement de surface (gravillon, sable, etc...) avec une capacité d'amortissement selon les normes CSA-Z614. Sauf avis contraire.

Zone de protection minimum requise:

- 14.1 m (46'-1.6") x 9.3 m (30'-7.3")
- Surface: 131.1 sq. m (1411.47 sq. ft.)
- Perimeter: 46.8m (153'-6")

PROTECTIVE SURFACING ZONE :

Each equipment shall have a protective surfacing zone that consist of obstacle-free surfacing surrounding the equipment. This zone shall contain shock absorbing material (pea gravel, sand, etc...) that comply with CSA-Z614. Unless noted otherwise.

Minimum Protective Surfacing Zone required:

- 14.1 m (46'-1.6") x 9.3 m (30'-7.3")
- Surface: 131.1 sq. m (1411.47 sq. ft.)
- Perimeter: 46.8m (153'-6")

MÉTHODES D'INSTALLATION

①

DANS LE BÉTON:

- Quantité de Sonotube de Ø12" x 12' :3

Béton:
 -1.5 m.cu.
 (1.96 vge.cu.)



INSTALLATION METHODS

①

CONCRETE

- Quantity of sonotube of 12"Øx12':3

CONCRETE
 -1.5 cu.m.
 (1.96cu.yd.)



②

SYSTÈME AUTO-PORTANT:

Qté charpentes: 8

Béton :
 - 0.0 m. cu.
 (0.0 vge cu.)



②

FREE-STANDING SYSTEM:

Frame QTY: 8

Concrete:
 -0.0 cu. m.
 -(0.0 cu. yd.)



Attention :

AIRE DE CIRCULATION LIBRE:

Aire dégagée d'obstacle qui se prolonge sur au moins 1.8m (70.87") au delà de la zone de protection. Voir dessin pour les détails.



Warning:

NO-ENCROACHMENT ZONE:

Obstacle-free zone extending at least 1.8m (70.87") beyond the protective surfacing zone. See drawing for details.



<p>kkids-165</p>	<p>Min. Protective Surface Required / Surface de protection min. requise 14.1 m (46'-1.6") x 9.3 m (30'-7.3")</p>	<p>Equipment Dimensions / Dimensions de l'équipement : 10.4 m (34'-1.6") x 5.7 m (18'-7.3")</p>	<p>Fall Height / Hauteur de chute: 2.29 m (7'-6")</p>	<p>Approval date: 2023-02-10 Rev: 00 Initial: S.T</p>
<p>CAN/CSA-Z614</p>	<p>Recommended Ages / Âges recommandés : 18 months to 12 years old / 18 mois à 12 ans</p>	<p>Capacity / Peut accueillir : up to 30 children / Jusqu'à 30 enfants</p>		