

SWING SEATS NOT INCLUDED
SIÈGES DE BALANÇOIRE NON-INCLUS

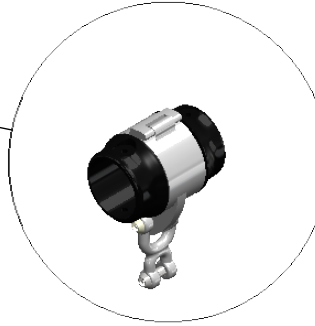

ANTI-WRAP
ANTIDERAPANT

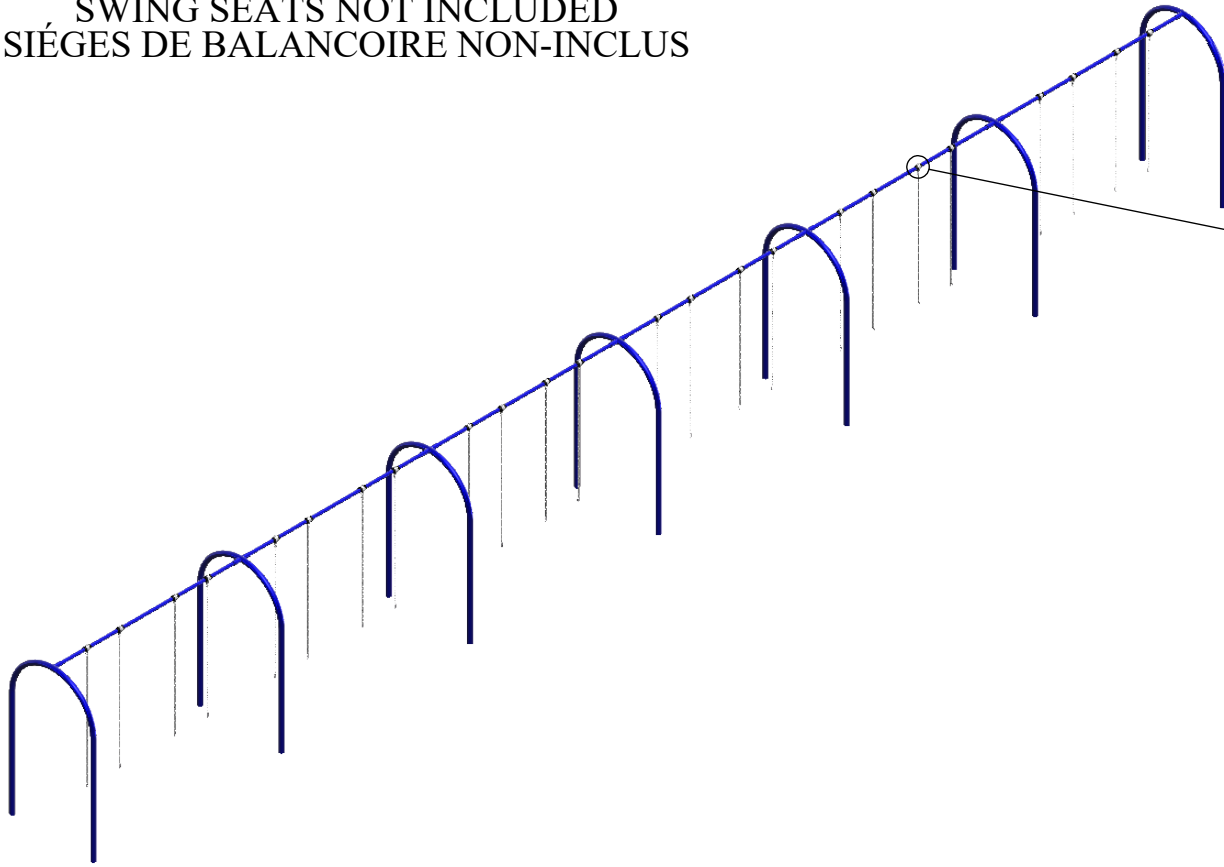

23 ch. Boom Lane, Unit/Unité E Industrial
 Park/Parc industriel Atholville, New/Nouveau-
 Brunswick Canada, E3N 4E8
 Tel/tél. : 1-888-212-1411/Fax/télé. : 1-888-
 789-0987 www.kangaroo.com



ALL STEEL

-ALLIED PRE-GALVINISED
 COVERED WITH A
 POLYESTER POWDER PAINT.

TOUT ACIER

PRÉ-GALVINISÉ "ALLIED"
 COUVERT D'UNE PEINTURE DE
 POUDRE DE POLYESTER.

CHAINS

1/4" GALVINISED CHAINS

CHAINES

CHAINES GALVANISÉES 1/4"

2 3/8" DIA STEEL ROUND TUBING
 TUBAU D'ACIER 2 3/8" DIA

[69'-10"]
 21.3m

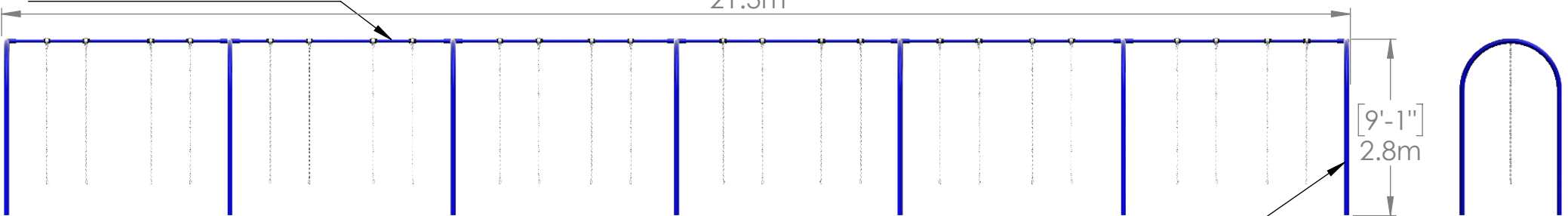

3 1/2" DIA STEEL ROUND TUBING
 TUBAU D'ACIER 3 1/2" DIA

SWARC-12

Min. Protective Surface Required / Surface de protection min. requise
 24.9m (81'-10") x 9.3m (30'-4")

Equipment Dimensions / Dimensions de l'équipement :
 21.3m (69'-10") x 2.8m (9'-1")

Approval date: 14-06-21

Rev: 00

CAN/CSA-Z614

Recommended Ages / Âges recommandés :
 18 months to 12 years old / 18 mois à 12 ans

Capacity / Peut accueillir : up to 12 children / Jusqu'à 12 enfants

Initial: AK





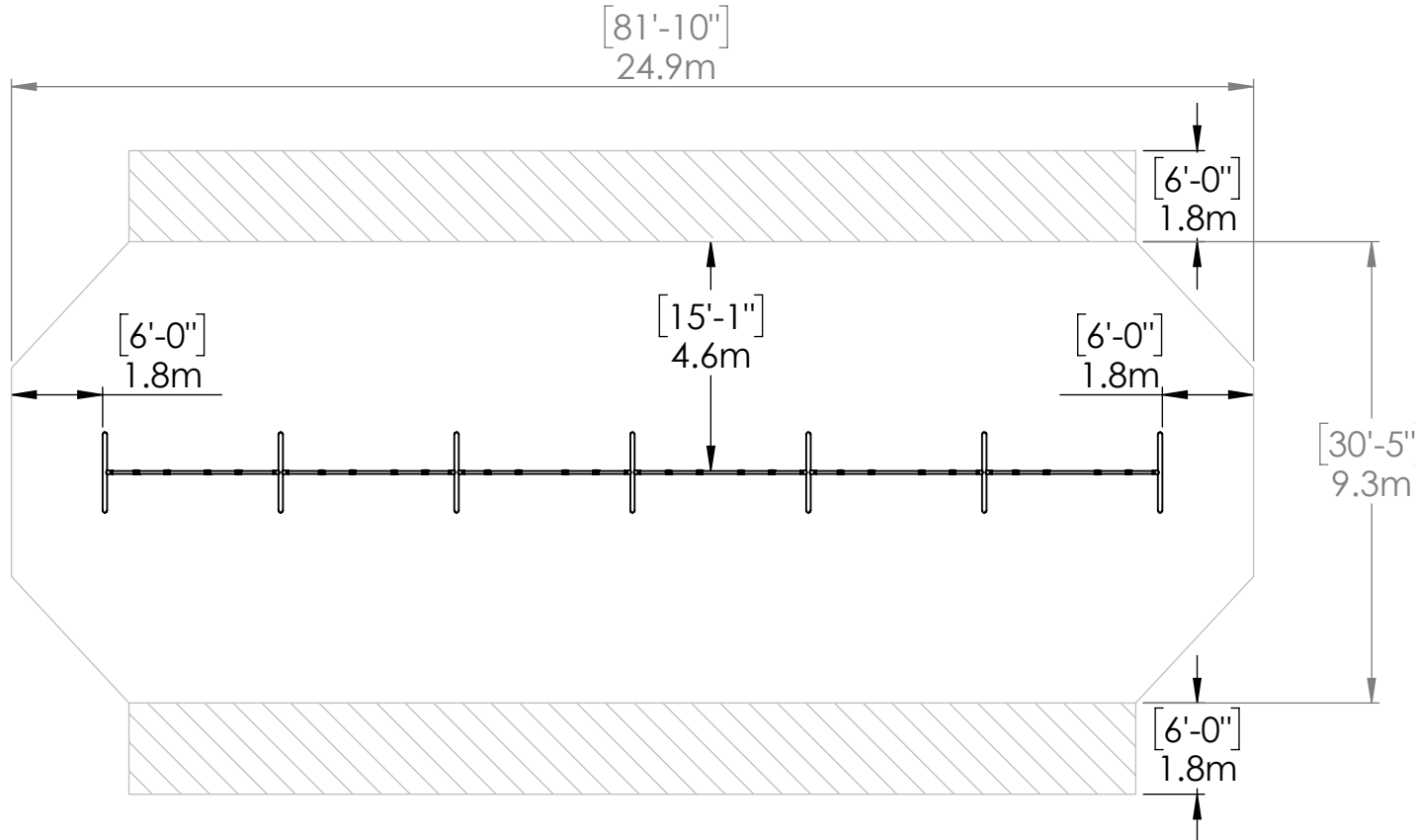



23 ch. Boom Lane, Unit/Unité E Industrial Park/Parc industriel
 Atholville, New/Nouveau-Brunswick Canada, E3N 4E8
 Tel/tél. : 1-888-212-1411/Fax/télé. : 1-888-789-0987
 www.kangoroo.com



PLATFORM HEIGHTS
 HAUTEURS DE PLATEFORME

12" = 305MM	24" = 609MM
36" = 915MM	48" = 1219MM
60" = 1524MM	72" = 1829MM
84" = 2134MM	96" = 2438MM



<p>ZONE DE PROTECTION: Chaque équipement doit avoir une zone de protection constituée d'une surface sans obstacle qui se prolonge dans toutes les directions à partir du périmètre de l'équipement. Cette zone doit contenir un revêtement de surface (gravillon, sable, etc...) avec une capacité d'amortissement selon les normes CSA-Z614. Sauf avis contraire. Zone de protection minimum requise: 24.9m (81'-10") x 9.3m (30'-5") - Surface: 231.57 sq. m (2492.6 sq. ft.) - Perimeter: 68.4 m (224'-4")</p>	<p>PROTECTIVE SURFACING ZONE : Each equipment shall have a protective surfacing zone that consist of obstacle-free surfacing surrounding the equipment. This zone shall contain shock absorbing material (pea gravel, sand, etc...) that comply with CSA-Z614. Unless noted otherwise. Minimum Protective Surfacing Zone required: 24.9m (81'-10") x 9.3m (30'-5") - Surface: 231.57 sq. m (2492.6 sq. ft.) - Perimeter: 68.4 m (224'-4")</p>
<p>MÉTHODES D'INSTALLATION 1 DANS LE BÉTON: - Quantité de Sonotube de 12" Ø x 12' :4 Béton: -1.4.cu. (1.8ge.cu.)</p> 	<p>INSTALLATION METHODS 1 CONCRETE -Quantity of sonotube of 12"Øx12':4 CONCRETE -1.4 cu.m. (1.8cu.yd.)</p> 
<p>2 SYSTÈME AUTO-PORTANT: Qté charpentes: 0 Béton : - 1.4 m. cu. (1.8 vge cu.)</p> 	<p>2 FREE-STANDING SYSTEM: Frame QTY: 0 Concrete: -1.4 cu. m. (-1.8 cu. yd.)</p> 
<p>Attention : AIRE DE CIRCULATION LIBRE: Aire dégagée d'obstacle qui se prolonge sur au moins 1.8m (70.87") au delà de la zone de protection. Voir dessin pour les détails.</p> 	<p>Warning: NO-ENCROACHMENT ZONE: Obstacle-free zone extending at least 1.8m (70.87") beyond the protective surfacing zone. See drawing for details.</p> 

<p>SWARC-12</p>	<p>Min. Protective Surface Required / Surface de protection min. requise 24.9m (81'-10") x 9.3m (30'-5")</p>	<p>Equipment Dimensions / Dimensions de l'équipement : 21.3m (69'-10") x 2.8m (9'-1")</p>	<p>Fall Height / Hauteur de chute: 2.8 m (9'-1")</p>	<p>Approval date: 14-06-21 Rev: 00 Initial: AK</p>
<p>CAN/CSA-Z614</p>	<p>Recommended Ages / Âges recommandés : 18 months to 12 years old / 18 mois à 12 ans</p>	<p>Capacity / Peut accueillir : up to 12 children / Jusqu'à 12 enfants</p>		