

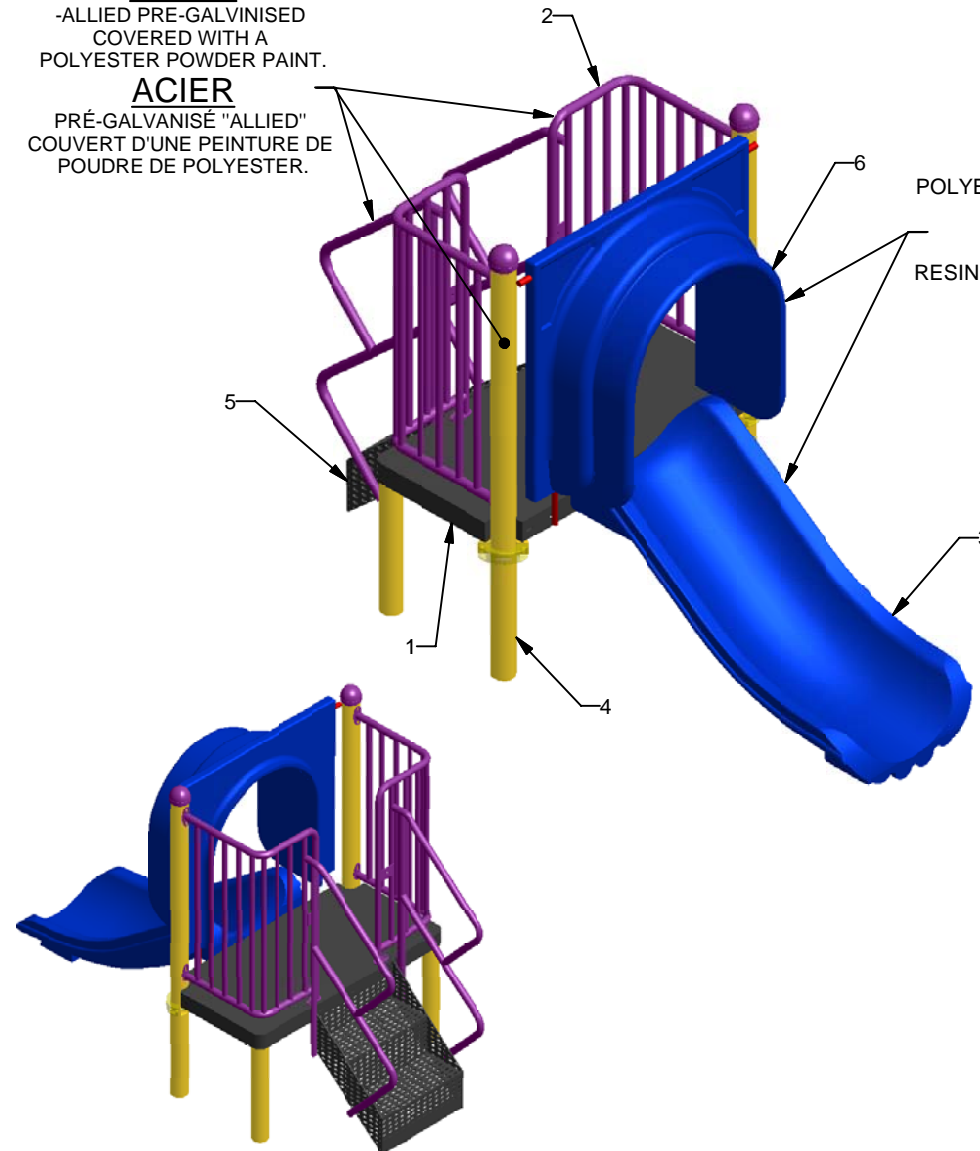

STEEL
 -ALLIED PRE-GALVANISED
 COVERED WITH A
 POLYESTER POWDER PAINT.
ACIER
 PRÉ-GALVANISÉ "ALLIED"
 COUVERT D'UNE PEINTURE DE
 POUDRE DE POLYESTER.

PLASTIC
 POLYETHYLENE RESIN WITH UV
 STABILIZER
PLASTIQUE
 RESIN DE POLYETHYLENE AVEC
 STABILISATEUR UV

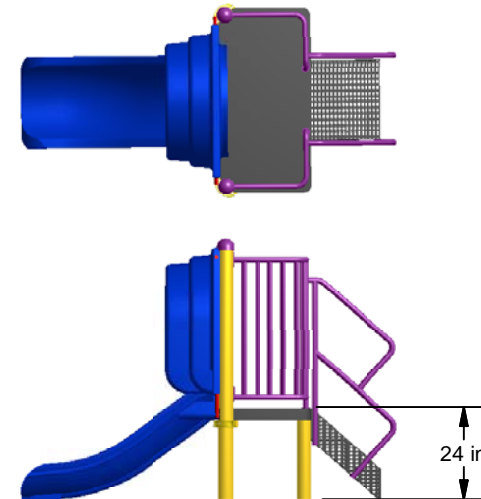

Legend / Légende	
#	Description
1	2' x 4' Platform / Plateforme 2' x 4'
2	Safety Rail / Barrière de protection
3	Double Wall Slide 24" / Glissoire simple 24"
4	3 1/2"Dia. Post / Poteau 3 1/2"Dia.
5	Stairs / Escalier
6	Slide Hood / Dispositif de glissoire



ST-207DM1	Min. Protective Surface Required / Surface de protection min. requise : 6.1 m (20'-2") x 4.9 m (16'-3")	Equipment Dimensions / Dimensions de l'équipement : 2.5 m (8'-2") x 1.3 m (4'-3")	Approval date: 2009-11-04 Rev: 00 Initial: TLG
CAN/CSA-Z614-07	Recommended Ages / Âges recommandés : 18 months to 5 years old / 18 mois à 5 ans	Capacity / Peut accueillir : up to 3 children / Jusqu'à 3 enfants	

PLATFORM HEIGHTS
HAUTEURS DE PLATEFORME

12" = 305MM	60" = 1524MM
24" = 609MM	72" = 1829MM
36" = 915MM	84" = 2134MM
48" = 1219MM	96" = 2438MM

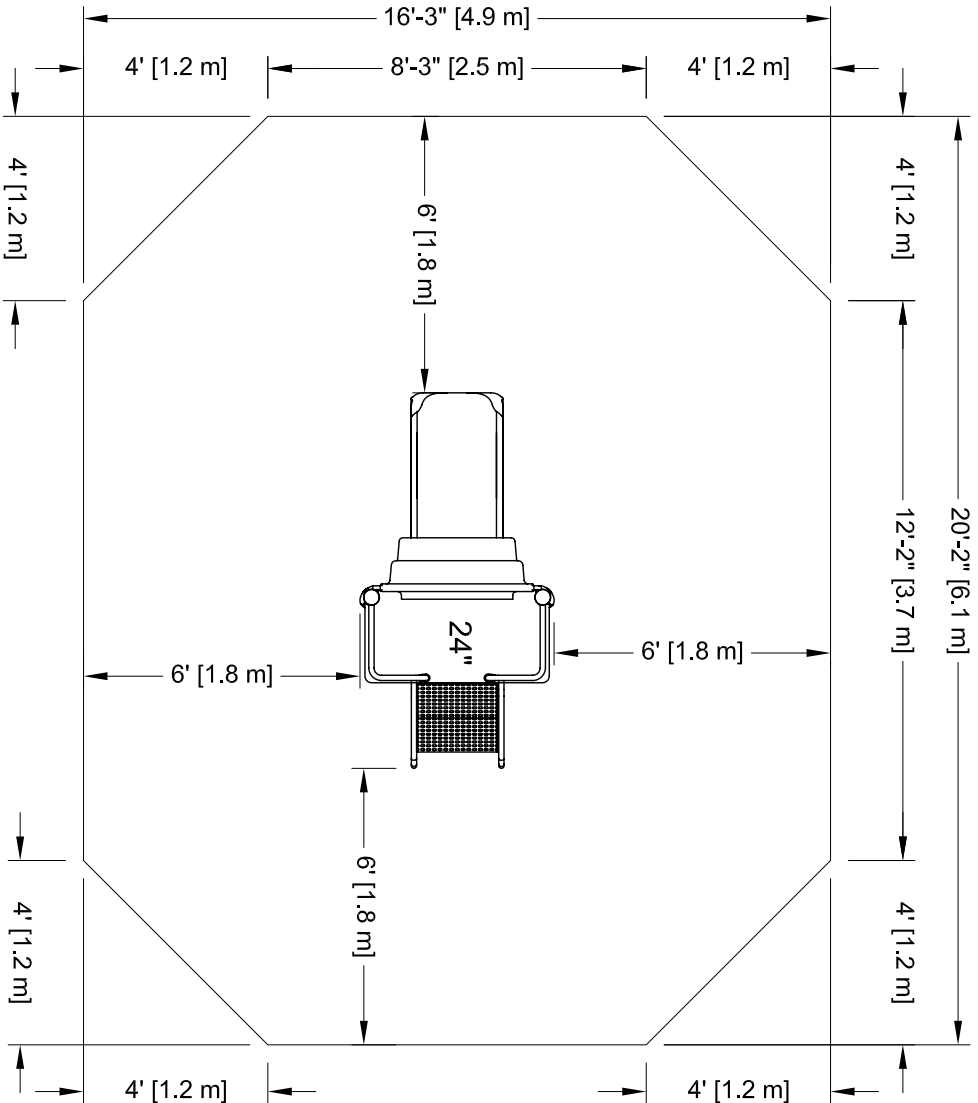

ST-207DM1

CAN/CSA-Z614-07

Min. Protective Surface Required / Surface de protection min. requise :

Equipment Dimensions / Dimensions de l'équipement :

6.1 m (20'-2") x 4.9 m (16'-3")

2.5 m (8'-2") x 1.3 m (4'-3")

Recommended Ages / Âges recommandés :

Capacity / Peut accueillir :

18 months to 5 years old / 18 mois à 5 ans

up to 3 children / Jusqu'à 3 enfants



23 ch. Boom Lane, Unit/Unité E
Industrial Park/Parc Industriel
Ahnsville, New/Neuveau-Brunswick
Canada, E3N 4E8
Tel/tel. : 1-888-212-1411/Fax/télé. : 1-888-789-0987
go@kangaroo.com / www.kangaroo.com

SURFACE DE PROTECTION

Attention :
Une aire de protection est requise dessous et autour de la structure de jeu.

Légende :
Aire de protection

Aire de circulation libre



Aire de protection recommandée :

- Aire : 27.37 m ca. (294.58 pi. ca.)

- Quantité : 10.92 vge cu, (8.35 m cu.) pour 305 mm (12") d'épaisseur.

Sonotube de 12" Ø x 12' :
- Quantité : 1

Ciment :
- 0.2 vge cu.

PROTECTIVE SURFACE

Warning:
A protective area is required under and around the play structure.

Legend:
Protective Surface

No-Encroachment Zone



Recommended Protective Surface:

- Surface: 27.37 sq. m (294.58 sq. ft.)

- Quantity: 10.92 cu. yd, (8.35 cu. m) for 305 mm (12") thickness.

Sonotube of 12" Ø x 12':
- Quantity: 1

Concrete:
- 0.2 cu. yd.

Approval date: 04-11-2009
Rev: 00
Initial: TLG

