

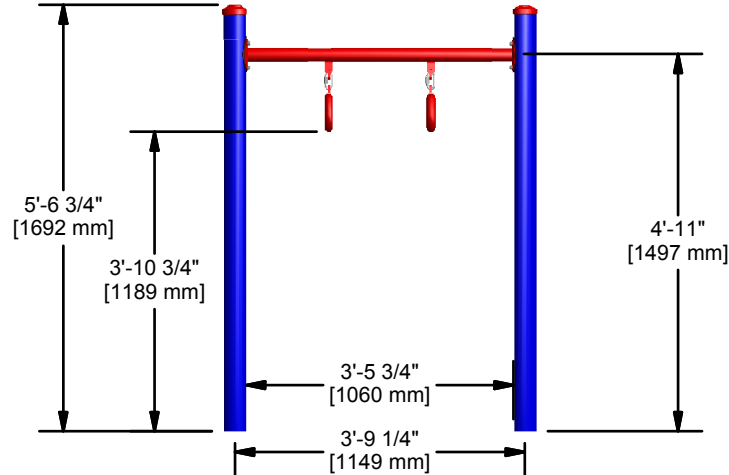

23 ch. Boom Lane, Unit/Unité E  
 Industrial Park/Parc industriel  
 Atholville, New/Nouveau-Brunswick  
 Canada, E3N 4E8  
 Tel/tél. : 1-888-212-1411/Fax/télec. : 1-888-789-0987  
 contact@kangoroo.com / www.kangoroo.com

**Colors / Couleurs**

Post / Poteaux: Blue/Bleu

Accent Color / Couleur complémentaire:  
 Red/Rouge



<p><b>SS-452</b></p>	<p>Min. Protective Surface Required / Surface de protection min. requise :          4.9 m (16'-1") x 3.9 m (12'-9")</p>	<p>Equipment Dimensions / Dimensions de l'équipement :          1.2 m (4'-1") x 0.2 m (0'-9")</p>	<p>Approval date: 05/02/2014          Rev: 00          Initial: TLG</p>
<p>CAN/CSA-Z614-xx          xx: Last Edition Published/          Dernière édition publiée</p>	<p>Recommended Ages / Âges recommandés :          5 to 12 years old / 5 à 12 ans</p>	<p>Capacity / Peut accueillir :          up to 1 children / Jusqu'à 1 enfants</p>	

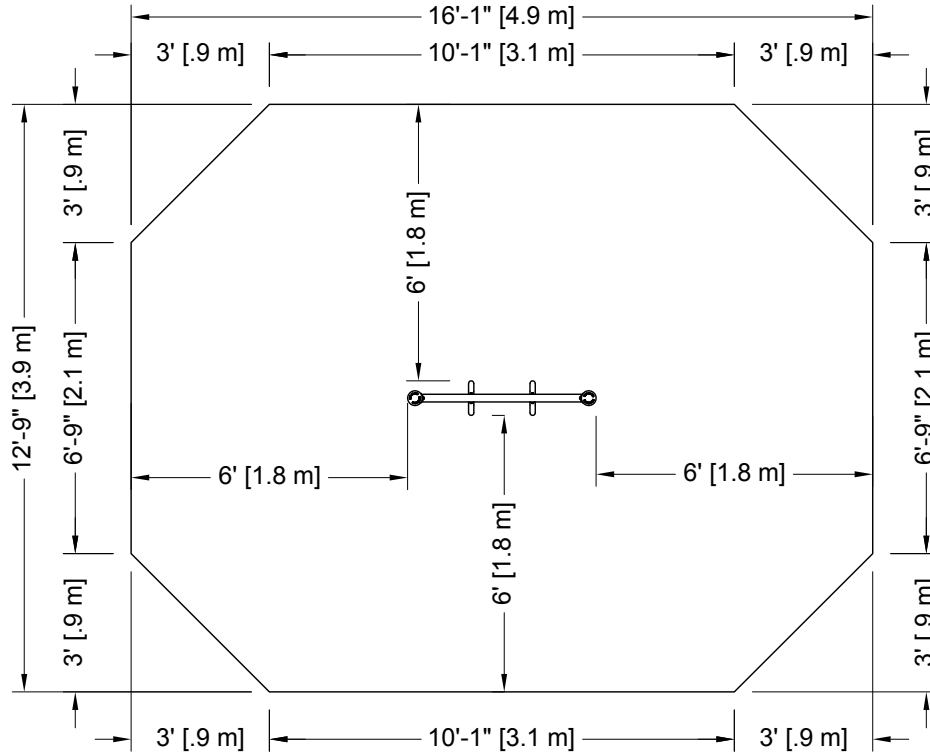

23 ch. Boom Lane, Unit/Unité E, Industrial Park/Parc industriel  
 Atholville, New/Nouveau-Brunswick  
 Canada, E3N 4E8  
 Tel/tél. : 1-888-212-1411 - Fax/télééc. : 1-888-789-0987  
 contact@kangoroo.com / www.kangoroo.com

**ZONE DE PROTECTION:**

Chaque équipement doit avoir une zone de protection constituée d'une surface sans obstacle qui se prolonge dans toutes les directions à partir du périmètre de l'équipement. Cette zone doit contenir un revêtement de surface (gravillon, sable, etc...) avec une capacité d'amortissement selon les normes CSA-Z614. Sauf avis contraire.

**Zone de protection minimum requise:**

4.9 m (16'-1")  
 x  
 3.9 m (12'-9")

- Aire : 17.39 m ca. (187.15 pi. ca.)
- Périmètre : 15.55 m (51'-0")

**PROTECTIVE SURFACING ZONE :**

Each equipment shall have a protective surfacing zone that consist of obstacle-free surfacing surrounding the equipment. This zone shall contain shock absorbing materi: (pea gravel, sand, etc...) that comply with CSA-Z614. Unless noted otherwise.

**Minimum**

**Protective Surfacing Zone required:**

4.9 m (16'-1")  
 x  
 3.9 m (12'-9")

- Surface: 17.39 sq. m (187.15 sq. ft.)
- Perimeter: 15.55 m (51'-0")

**MÉTHODES D'INSTALLATION**

1

**DANS LE BÉTON:**

- Quantité de Sonotube de 12" Ø x 12" : 1

Béton :  
 - 0.2 m. cu. (0.2 vge cu.)



1

**CONCRETE:**

- Quantity of Sonotube of 12" Ø x 12": 1

Concrete:  
 - 0.2 cu. m. (0.2 cu. yd.)

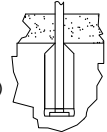

2

**SYSTÈME AUTO-PORTANT:**

Qté charpentes: 0  
 Béton :  
 - 0.2 m. cu. (0.2 vge cu.)



2

**FREE-STANDING SYSTEM**

Frame QTY: 0  
 Concrete:  
 - 0.2 cu. m. (0.2 cu. yd.)



**Attention :**

**AIRE DE CIRCULATION LIBRE:**

Aire dégagée d'obstacle qui se prolonge sur au moins 1.8m (70.87") au delà de la zone de protection. Voir dessin pour les détails.

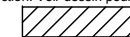

**Warning:**

**NO-ENCROACHMENT ZONE**

Obstacle-free zone extending at least 1.8r (70.87") beyond the protective surfacing zor See drawing for details.



**SS-452**

Equipment Dimensions / Dimensions de l'équipement :  
 1.2 m (4'-1") x 0.2 m (0'-9")

Recommended Ages / Âges recommandés :

5 to 12 years old  
 58 à 12 ans

Fall Height /  
 Hauteur de chute:  
 1.50 m (4'-11")

Approval date: 05-02-2014

Rev: 00  
 Initial: TLG



CAN/CSA-Z614-xx  
 xx: Last Edition Published /  
 Dernière édition publiée

Capacity / Peut accueillir :  
 up to 1 children / Jusqu'à 1 enfants