

SS-351

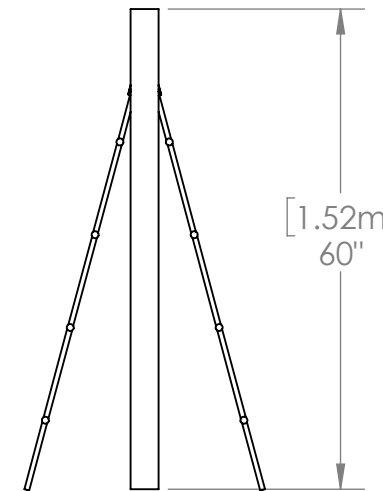

23 ch. Boom Lane, Unit/Unité E Industrial
 Park/Parc industriel Atholville, New/Nouveau-
 Brunswick Canada, E3N 4E8
 Tel/tél. : 1-888-212-1411/Fax/télé. : 1-888-
 789-0987 www.kangaroo.com

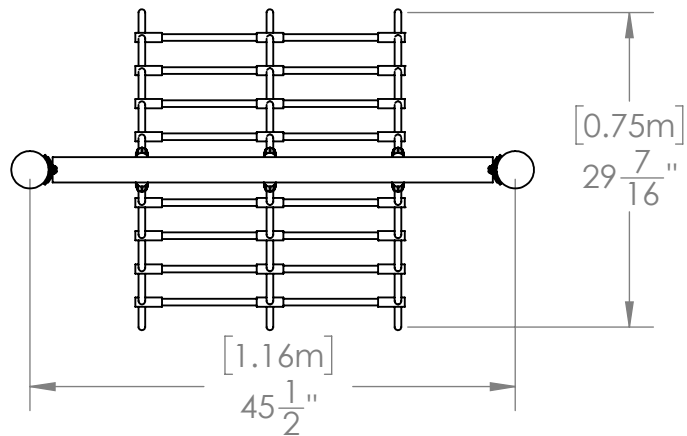
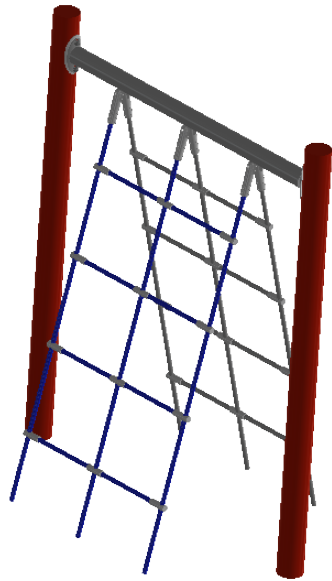

ss-351

Min. Protective Surface Required / Surface de protection min. requise
 . m (-") x .m (-")

Equipment Dimensions / Dimensions de l'équipement :
 1.16m (3'-9.5") x 0.75m (2'-5.5")

Approval date: 2021-04-22

Rev: 00

CAN/CSA-Z614

Recommended Ages / Âges recommandés :
 months to years old / mois à ans

Capacity / Peut accueillir : up to x children / Jusqu'à x enfants

Initial: S.T