

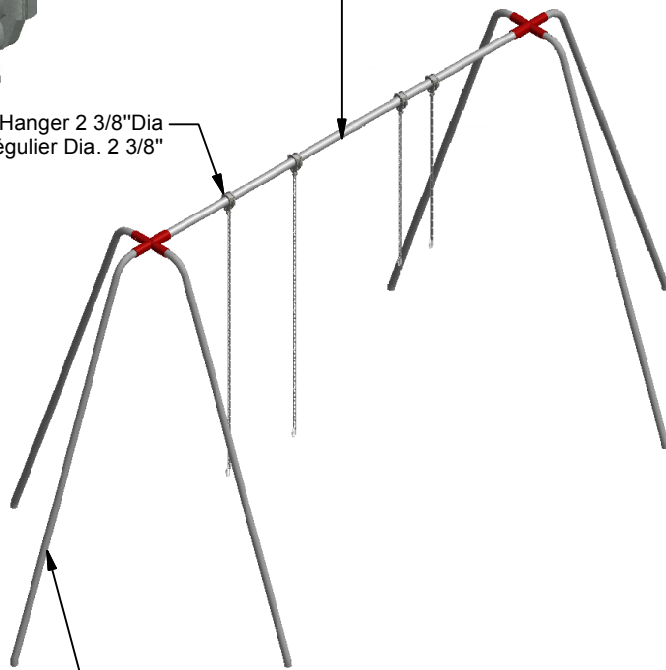

2 3/8"Dia. Galv. Beam
Traverse galv 2 3/8"Dia

Regular Galv. Swing Hanger 2 3/8"Dia
Joint porteur galv. régulier Dia. 2 3/8"



2"Dia Galv. Legs
Pattes galv. 2"Dia



23 ch. Boom Lane, Unit/Unité E
Industrial Park/Parc industriel
Atholville, New/Novveau-Brunswick
Canada, E3N 4E8
Tel/tél. : 1-888-212-1411/Fax/télééc. : 1-888-789-0987
www.kangoroo.com

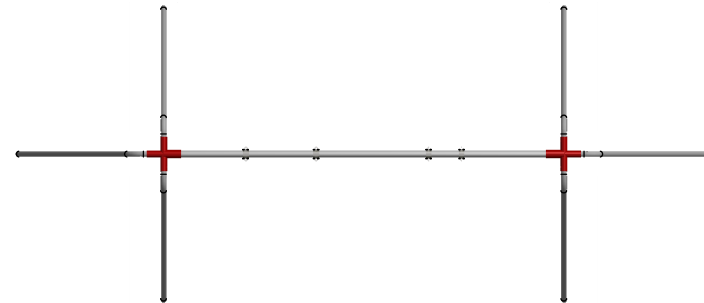
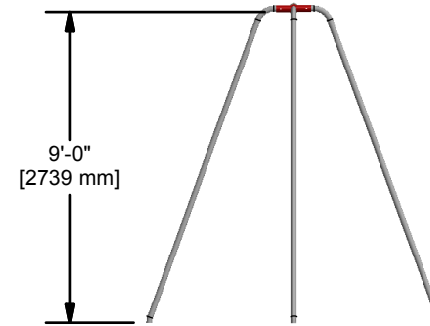

STEEL

BRACKETS ARE COVERED WITH A
POLYESTER POWDER PAINT.

ACIER

LES SUPPORTS DE PATTES SONT
COUVERT D'UNE PEINTURE DE
POUDRE DE POLYESTER.

REGSW-2	Min. Protective Surface Required / Surface de protection min. requise : 7.2 m (23'-9") x 9.3 m (30'-8")	Equipment Dimensions / Dimensions de l'équipement : 6.1 m (20'-2") x 2.6 m (8'-7")	Approval date: 13/07/2017 Rev: 02 Initial: TLG
CAN/CSA-Z614-xx xx: Last Edition Published/ Dernière édition publiée	Recommended Ages / Âges recommandés : 18 mois à 12 ans / 18 months to 12 years old	Capacity / Peut accueillir : up to 2 children / Jusqu'à 2 enfants	



23 ch. Boom Lane, Unit/Unité E, Industrial Park/Parc industriel
 Atholville, New/Nouveau-Brunswick
 Canada, E3N 4E8
 Tel/tél. : 1-888-212-1411 - Fax/télééc. : 1-888-789-0987
 contact@kangoroo.com / www.kangoroo.com

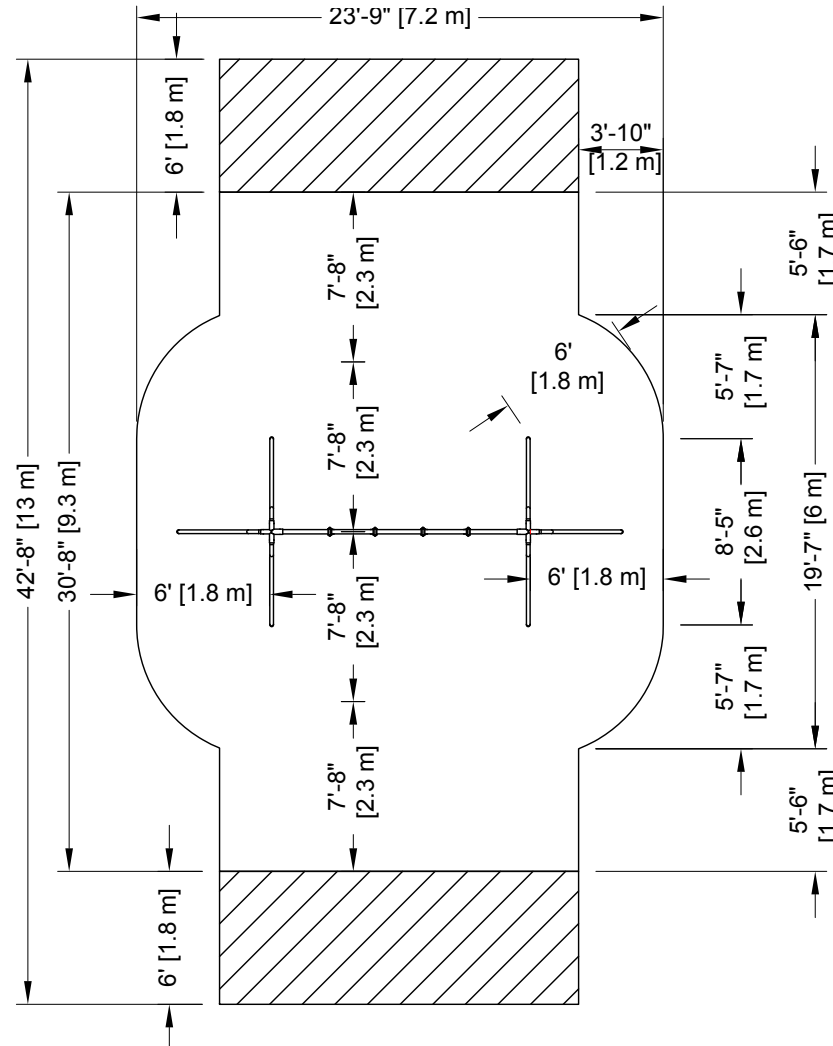

ZONE DE PROTECTION:

Chaque équipement doit avoir une zone de protection constituée d'une surface sans obstacle qui se prolonge dans toutes les directions à partir du périmètre de l'équipement. Cette zone doit contenir un revêtement de surface (gravillon, sable, etc...) avec une capacité d'amortissement selon les normes CSA-Z614. Sauf avis contraire.

Zone de protection minimum requise:

7.2 m (23'-9")
 x
 9.3 m (30'-8")

- Aire : 57.78 m ca. (621.94 pi. ca.)
- Périmètre : 30.79 m (101'-0")

PROTECTIVE SURFACING ZONE :

Each equipment shall have a protective surfacing zone that consist of obstacle-free surfacing surrounding the equipment. This zone shall contain shock absorbing material (pea gravel, sand, etc...) that comply with CSA-Z614. Unless noted otherwise.

Minimum

Protective Surfacing Zone required:

7.2 m (23'-9")
 x
 9.3 m (30'-8")

- Surface: 57.78 sq. m (621.94 sq. ft.)
- Perimeter: 30.79 m (101'-0")

MÉTHODES D'INSTALLATION

1

DANS LE BÉTON:

- Quantité de Sonotube de 12" Ø x 12" : 2

Béton :
 - 0.46 m. cu.
 (0.6 vge cu.)



1

CONCRETE:

- Quantity of Sonotube of 12" Ø x 12": 2

Concrete:
 - 0.46 cu. m.
 (0.6 cu. yd.)

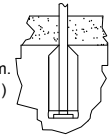

2

SYSTÈME AUTO-PORTANT:

Qté charpentes: **NA**

Béton :
 - NA m. cu.
 (NA vge cu.)



2

FREE-STANDING SYSTEM

Frame QTY: **NA**

Concrete:
 - NA cu. m.
 (NA cu. yd.)

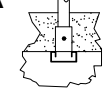

Attention :

AIRE DE CIRCULATION LIBRE:

Aire dégagée d'obstacle qui se prolonge sur au moins 1.8m (70.87") au delà de la zone de protection. Voir dessin pour les détails.



Warning:

NO-ENCROACHMENT ZONE

Obstacle-free zone extending at least 1.8m (70.87") beyond the protective surfacing zone. See drawing for details.



REGSW-2

Equipment Dimensions / Dimensions de l'équipement :
 6.1 m (20'-2") x 2.6 m (8'-7")

Recommended Ages / Âges recommandés :
 18 months to 12 years old
 18 mois à 12 ans

Fall Height /
 Hauteur de chute:
 2.74 m (9'-0")

Approval date: 13-07-2017
 Rev: 02
 Initial: TLG



CAN/CSA-Z614-xx
 xx: Last Edition Published /
 Dernière édition publiée

Capacity / Peut accueillir :
 up to 2 children / Jusqu'à 2 enfants