

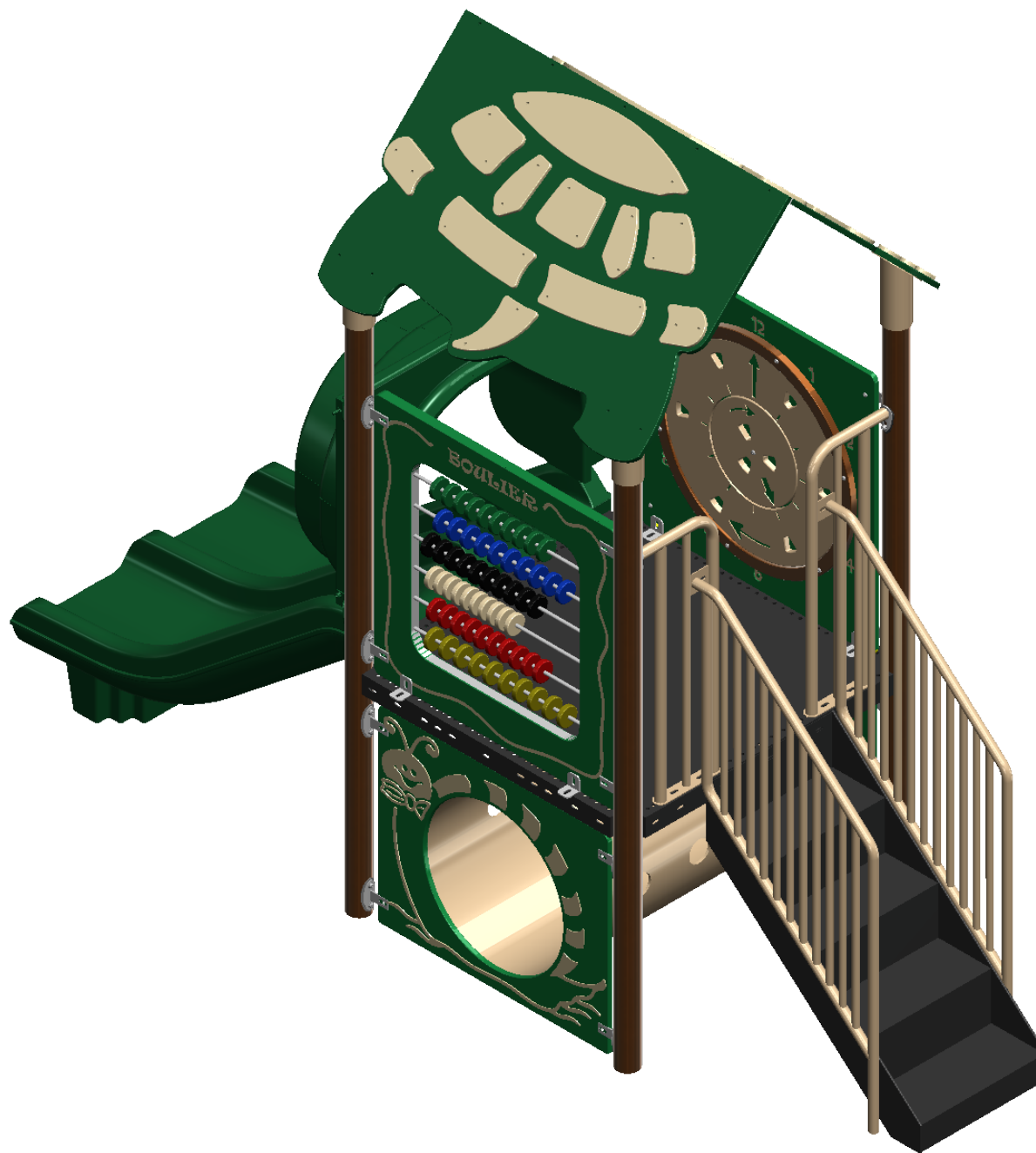

23 ch. Boom Lane, Unit/Unité E Industrial
Park/Parc industriel Atholville, New/Nouveau-
Brunswick Canada, E3N 4E8
Tel/tél. : 1-888-212-1411/Fax/téloc. : 1-888-
789-0987 www.kangoroo.com



KTODD-138M2

Min. Protective Surface Required / Surface de protection min. requise
5.2 m (17'-1") x 7.3 m (24'-0")

Equipment Dimensions / Dimensions de l'équipement :
1.6m (5'-1") x 3.7m (12'-0")

Approval date: 16-03-21

Rev: 00

Initial: AK

CAN/CSA-Z614

Recommended Ages / Âges recommandés :
18 months to 5 years old / 18 mois à 5 ans

Capacity / Peut accueillir : up to 15 children / Jusqu'à 15 enfants



23 ch. Boom Lane, Unit/Unité E Industrial
Park/Parc industriel Atholville, New/Nouveau-
Brunswick Canada, E3N 4E8
Tel/tél. : 1-888-212-1411/Fax/télé. : 1-888-
789-0987 www.kangoroo.com



KTODD-138M2

Min. Protective Surface Required / Surface de protection min. requise
5.2 m (17'-1") x 7.3 m (24'-0")

Equipment Dimensions / Dimensions de l'équipement :
1.6m (5'-1") x 3.7m (12'-0")

Approval date: 16-03-21

Rev: 00

Initial: AK

CAN/CSA-Z614

Recommended Ages / Âges recommandés :
18 months to 5 years old / 18 mois à 5 ans

Capacity / Peut accueillir : up to 15 children / Jusqu'à 15 enfants



23 ch. Boom Lane, Unit/Unité E Industrial
 Park/Parc industriel Atholville, New/Nouveau-
 Brunswick Canada, E3N 4E8
 Tel/tél. : 1-888-212-1411/Fax/télé. : 1-888-
 789-0987 www.kangoroo.com

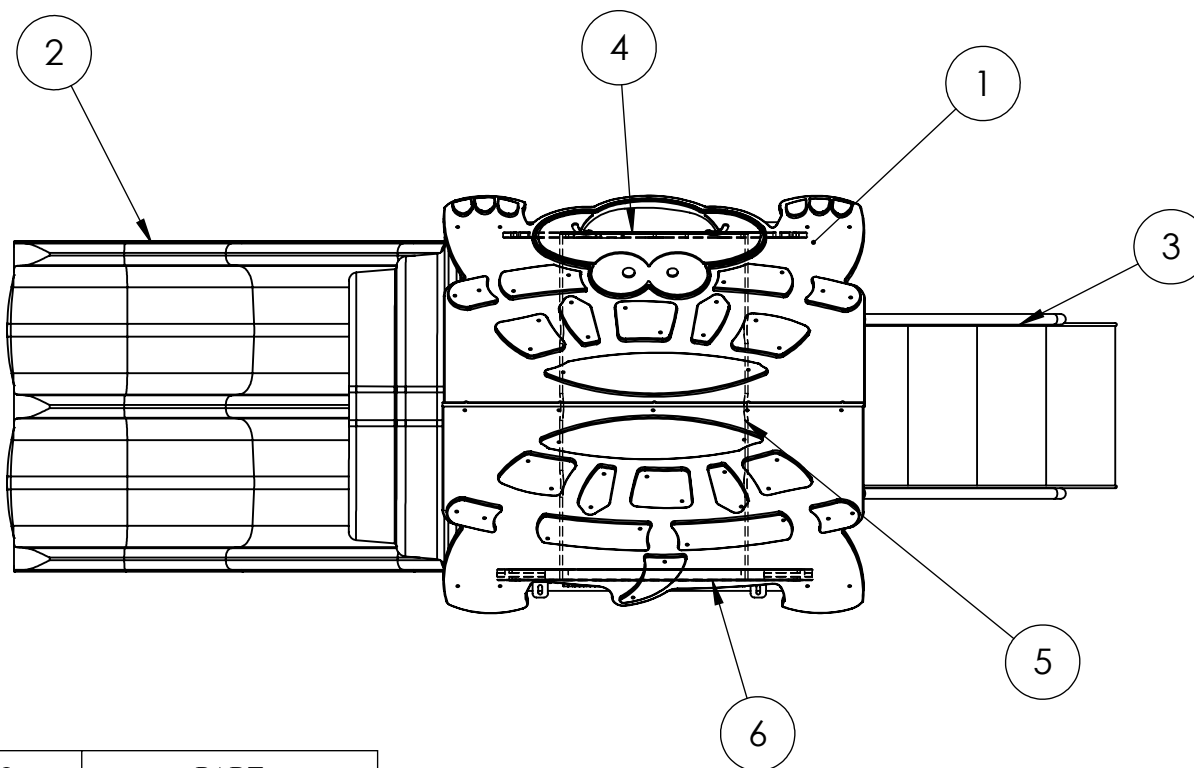

ITEM	QTY	DESCRIPTION	PART
1	1	HDPE TURTLE ROOF/TOIT HDPE TORTUE	HDPE-TRTL-RF
2	1	TRIPLE RAIL SLIDE 36"/GLISSORIE DOUBLE 36"	FS-3TRS
3	1	Full Hand Rail Stairs 36"/Escaliers a main courante pleine 36"	FS-STAIR-36"
4	1	KG-clock/Panneau Clock	KG-CLOCK
5	1	Post to Post Tunnel 24Dia X 45.5l/Tunnel 24Dia x 45.5L, poteax a poteaux	PTP-TUN-24Dia-45L
6	1	KG Abacus/ Boulrier KG	KG-Abacus

KTODD-138M2

Min. Protective Surface Required / Surface de protection min. requise
 5.2 m (17'-1") x 7.3 m (24'-0")

Equipment Dimensions / Dimensions de l'équipement :
 1.6m (5'-1") x 3.7m (12'-0")

Approval date: 16-03-21

Rev: 00

Initial: AK

CAN/CSA-Z614

Recommended Ages / Âges recommandés :
 18 months to 5 years old / 18 mois à 5 ans

Capacity / Peut accueillir : up to 15 children / Jusqu'à 15 enfants



23 ch. Boom Lane, Unit/Unité E Industrial Park/Parc industriel
 Atholville, New/Nouveau-Brunswick Canada, E3N 4E8
 Tel/tél. : 1-888-212-1411/Fax/télé. : 1-888-789-0987
 www.kangoroo.com

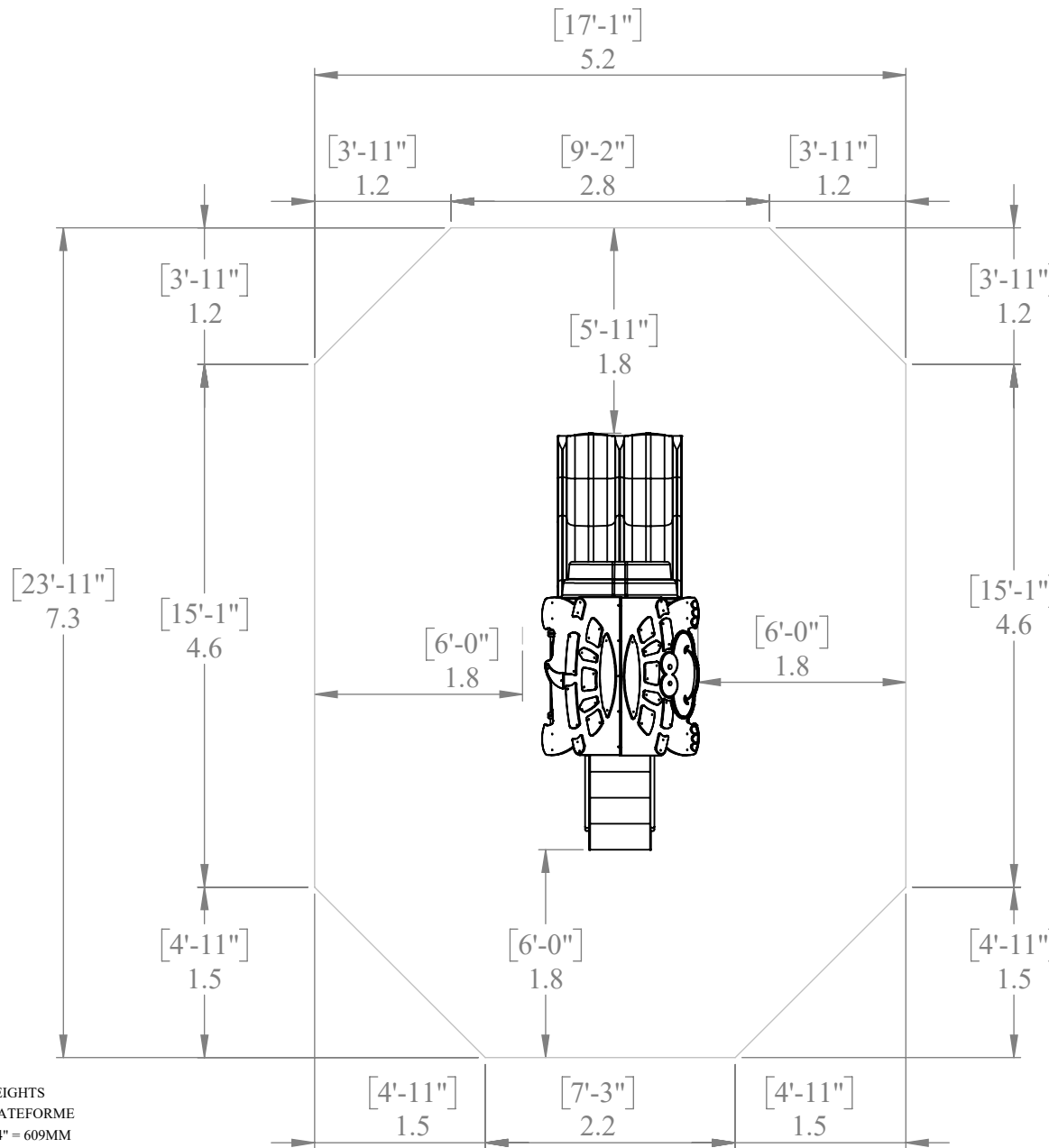

PLATFORM HEIGHTS
HAUTEURS DE PLATEFORME
 12" = 305MM 24" = 609MM
 36" = 915MM 48" = 1219MM
 60" = 1524MM 72" = 1829MM
 84" = 2134MM 96" = 2438MM



ZONE DE PROTECTION:

Chaque équipement doit avoir une zone de protection constituée d'une surface sans obstacle qui se prolonge dans toutes les directions à partir du périmètre de l'équipement. Cette zone doit contenir un revêtement de surface (gravillon, sable, etc...) avec une capacité d'amortissement selon les normes CSA-Z614.
 Sauf avis contraire.

Zone de protection minimum requise:
 5.2 m (17'-1")
 x
 7.3 m (24'-0")
 - Surface: 34.36 sq. m (369.81 sq. ft.)
 - Perimeter: 21.95 m (72'-0")

PROTECTIVE SURFACING ZONE :

Each equipment shall have a protective surfacing zone that consist of obstacle-free surfacing surrounding the equipment. This zone shall contain shock absorbing material (pea gravel, sand, etc...) that comply with CSA-Z614. Unless noted otherwise.

Minimum Protective Surfacing Zone required:
 5.2 m (17'-1")
 x
 7.3 m (24'-0")
 - Surface: 34.36 sq. m (369.81 sq. ft.)
 - Perimeter: 21.95 m (72'-0")

MÉTHODES D'INSTALLATION

①

DANS LE BÉTON:

- Quantité de Sonotube de 12" Ø x 12' :3

Béton:
 -1.1m.cu.
 (1.4vge.cu.)



INSTALLATION METHODS

①

CONCRETE

-Quantity of sonotube of 12"Øx12':3

CONCRETE
 -1.1 cu.m.
 (1.4cu.yd.)



②

SYSTÈME AUTO-PORTANT:

Qté charpentes: 2

Béton :
 - 1.1 m. cu.
 (1.4 vge cu.)

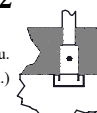

②

FREE-STANDING SYSTEM:

Frame QTY: 2

Concrete:
 -0.3 cu. m.
 -(0.3 cu. yd.)



Attention :

AIRE DE CIRCULATION LIBRE:
 Aire dégagée d'obstacle qui se prolonge sur au moins 1.8m (70.87") au delà de la zone de protection. Voir dessin pour les détails.



Warning:

NO-ENCROACHMENT ZONE :
 Obstacle-free zone extending at least 1.8m (70.87") beyond the protective surfacing zone. See drawing for details.



KTODD-138M1

Min. Protective Surface Required / Surface de protection min. requise
 5.2 m (17'-1") x 7.3 m (24'-0")

Equipment Dimensions / Dimensions de l'équipement : 1.6 m (5'-1") x 3.7 m (12'-0")

Fall Height / Hauteur de chute:
 1.98 m (6'-6")

Approval date: 16-03-21

CAN/CSA-Z614

Recommended Ages / Âges recommandés :
 18 months to 5 years old / 18 mois à 5 ans

Capacity / Peut accueillir : up to 15 children / Jusqu'à 15 enfants

Rev: 00

Initial: AK