



23 ch. Boom Lane, Unit/Unité E
 Industrial Park/Parc industriel
 Atholville, New/Nouveau-Brunswick
 Canada, E3N 4E8
 Tel/tél. : 1-888-212-1411/Fax/télec. : 1-888-789-0987
 go@kangoroo.com / www.kangoroo.com

Colors / Couleurs

Post / Poteaux: Blue/Bleu

Accent Color / Couleur complémentaire:
 Yellow/Jaune

1 Color panel / Panneaux 1 couleur: Red/Rouge

2 colors panel / Panneaux 2 couleurs :
 Red & White/Rouge et blanc

Slide / Glissoire: Spring Green/Vert printanier

Plastic Climbers / Grimpeur Plastique:
 NA

Cable / Cable : NA

Roof / Toît : Spring Green/Vert printanier

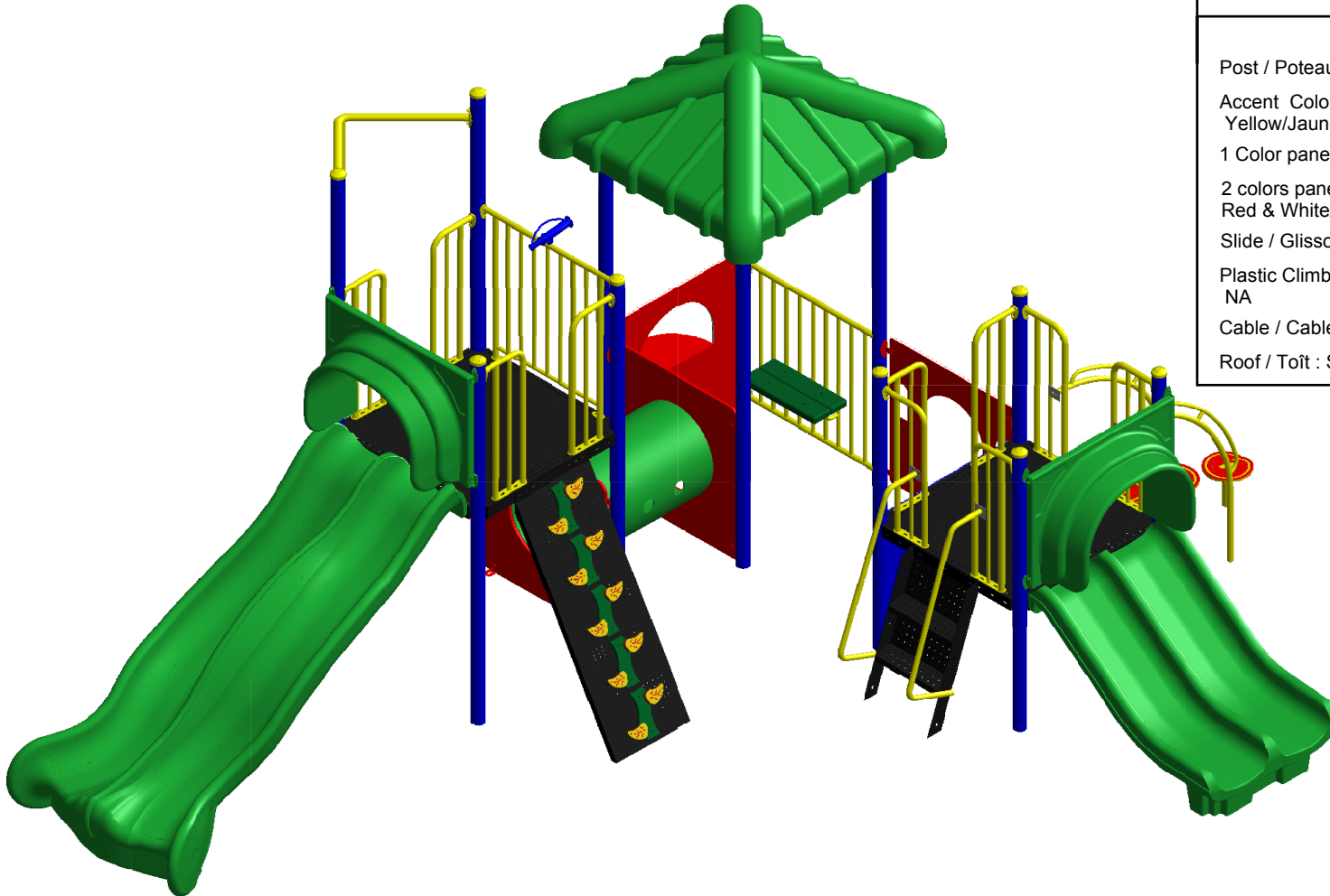

Ktodd-127

Min. Protective Surface Required / Surface de protection min. requise :
 11.0 m (36'-1") x 9.3 m (30'-7")

Equipment Dimensions / Dimensions de l'équipement :
 7.3 m (24'-1") x 5.7 m (18'-7")

Approval date: 16/10/2014

Rev: 00

Initial: TLG

CAN/CSA-Z614-xx
 xx: Last Edition Published/
 Dernière édition publiée

Recommended Ages / Âges recommandés :
 18 months to 5 years old / 18 mois à 5 ans

Capacity / Peut accueillir :
 up to 40 children / Jusqu'à 40 enfants





23 ch. Boom Lane, Unit/Unité E
 Industrial Park/Parc industriel
 Atholville, New/Nouveau-Brunswick
 Canada, E3N 4E8
 Tel/tél. : 1-888-212-1411/Fax/télééc. : 1-888-789-0987
 go@kangaroo.com / www.kangaroo.com



Ktodd-127	Min. Protective Surface Required / Surface de protection min. requise : 11.0 m (36'-1") x 9.3 m (30'-7")	Equipment Dimensions / Dimensions de l'équipement : 7.3 m (24'-1") x 5.7 m (18'-7")	Approval date: 16/10/2014 Rev: 00 Initial: TLG
CAN/CSA-Z614-xx xx: Last Edition Published/ Dernière édition publiée	Recommended Ages / Âges recommandés : 18 months to 5 years old / 18 mois à 5 ans	Capacity / Peut accueillir : up to 40 children / Jusqu'à 40 enfants	



23 ch. Boom Lane, Unit/Unité E
 Industrial Park/Parc industriel
 Atholville, New/Nouveau-Brunswick
 Canada, E3N 4E8
 Tel/tél. : 1-888-212-1411/Fax/télééc. : 1-888-789-0987
 go@kangaroo.com / www.kangaroo.com

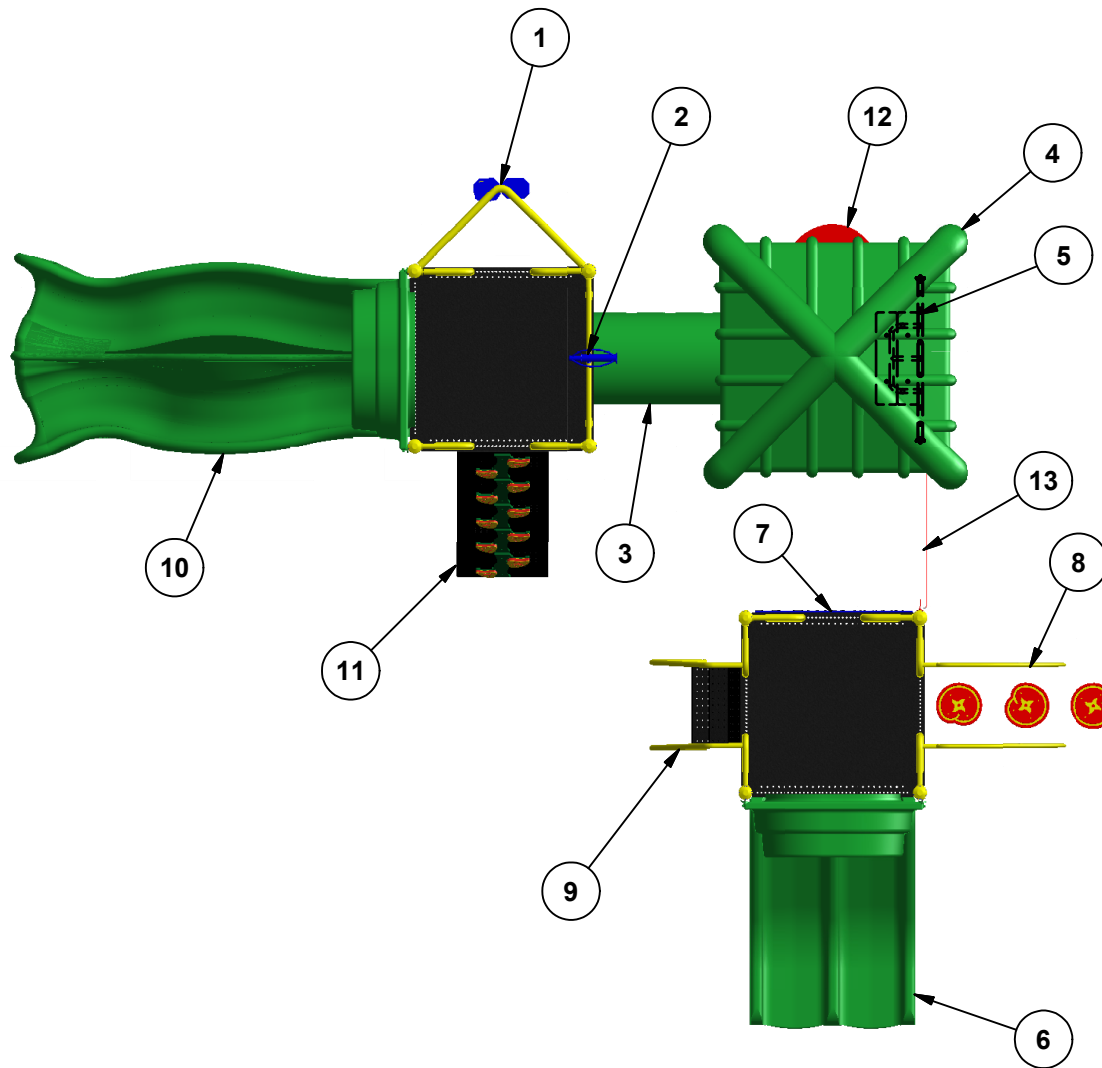

Legend / Légende

ITEM	QTY	Description	PART # / # PIECE
1	1	Bean Climber 60"/ Échelle haricots 60"	FS-BN-CL-60
2	1	Telescope Panel / Panneau télescope	AC-TSCOPE
3	1	Tunnel / Tunnel	DTD-TUN-24Dia
4	1	Double Wall Pyramid Roof/Toit pyramide a double paroi	PYRA-RF
5	1	Bench / Banc	AC-BENCH
6	1	Triple Rail Slide 36"/Glissoire double 36"	3TRS
7	1	Ice Climber 36"/ Escaladeur de glace 36"	ICE-CL-36
8	1	LillyPad Climber 36" / Grimpeur nénuphars 36"	FS-LILYPAD-36
9	1	Enclosed Step Ladder 36"/Échelle à marches fermées 36"	FS-STP-36
10	1	Duo-Slide 60"/Glissoire double "Duo-Slide" 60"	5TRS
11	1	BeanStalk Hike 60"/Haricot magique 60"	BNST-HK-60
12	1	KG Ice Cream Shop/ Comptoir crème glacée KG	KG-ICE-CRMSHP
13	1	KG House Entrance / Entrée de maisonnette KG	KG-HOUSE

Ktodd-127

Min. Protective Surface Required / Surface de protection min. requise :
 11.0 m (36'-1") x 9.3 m (30'-7")

Equipment Dimensions / Dimensions de l'équipement :
 7.3 m (24'-1") x 5.7 m (18'-7")

Approval date: 16/10/2014

Rev: 00

Initial: TLG

CAN/CSA-Z614-xx
 xx: Last Edition Published/
 Dernière édition publiée

Recommended Ages / Âges recommandés :
 18 months to 5 years old / 18 mois à 5 ans

Capacity / Peut accueillir :
 up to 40 children / Jusqu'à 40 enfants





23 ch. Boom Lane, Unit/Unité E, Industrial Park/Parc industriel
 Atholville, New/Nouveau-Brunswick
 Canada, E3N 4E8
 Tel/tél. : 1-888-212-1411 - Fax/télééc. : 1-888-789-0987
 contact@kangoroo.com / www.kangoroo.com

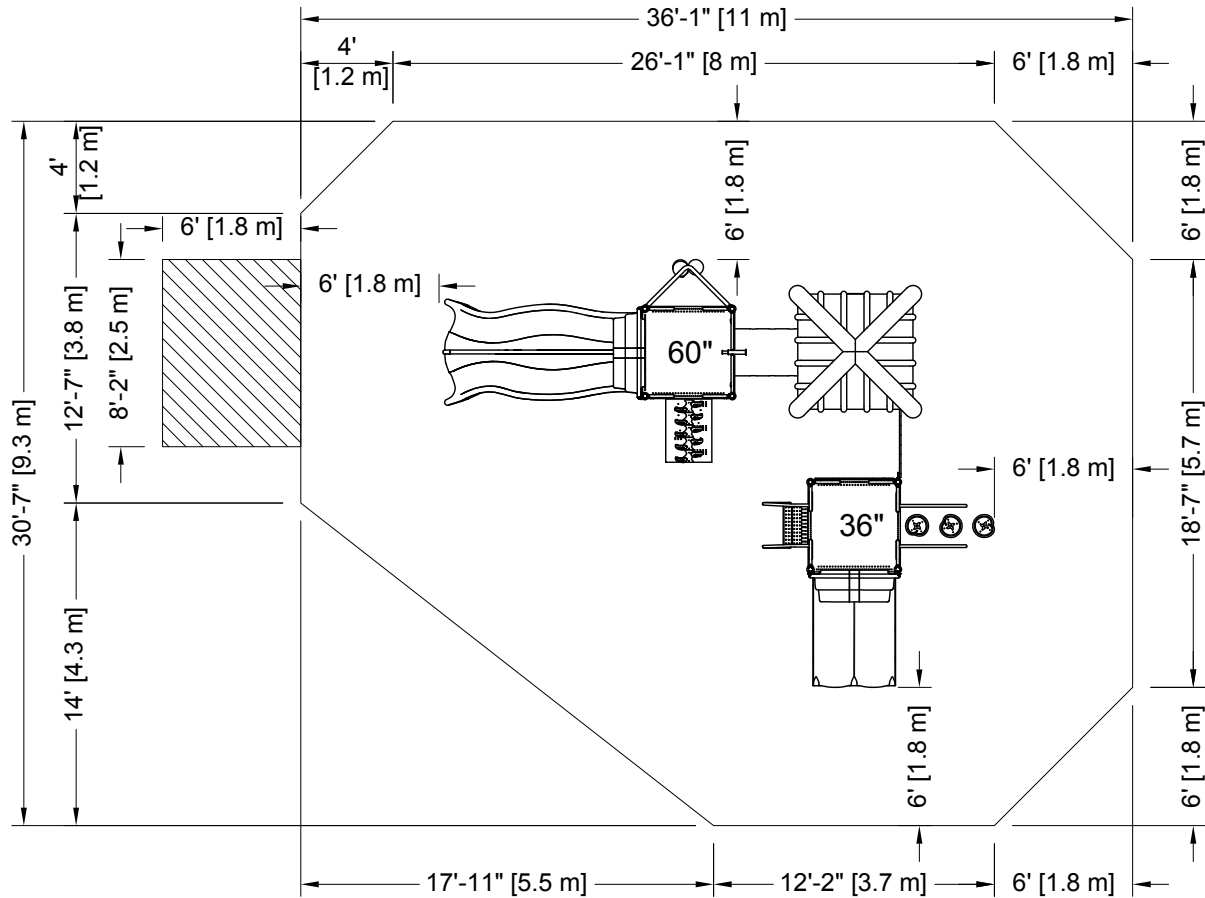

PLATFORM HEIGHTS
 HAUTEURS DE PLATEFORME

12" = 305MM	60" = 1524MM
24" = 609MM	72" = 1829MM
36" = 915MM	84" = 2134MM
48" = 1219MM	96" = 2438MM

ZONE DE PROTECTION:

Chaque équipement doit avoir une zone de protection constituée d'une surface sans obstacle qui se prolonge dans toutes les directions à partir du périmètre de l'équipement. Cette zone doit contenir un revêtement de surface (gravillon, sable, etc...) avec une capacité d'amortissement selon les normes CSA-Z614. Sauf avis contraire.

Zone de protection minimum requise:

11.0 m (36'-1")
 x
 9.3 m (30'-7")

- Aire : 86.79 m ca. (934.22 pi. ca.)
- Périmètre : 35.06 m (115'-0")

PROTECTIVE SURFACING ZONE :

Each equipment shall have a protective surfacing zone that consist of obstacle-free surfacing surrounding the equipment. This zone shall contain shock absorbing material (pea gravel, sand, etc...) that comply with CSA-Z614. Unless noted otherwise.

Minimum Protective Surfacing Zone required:

11.0 m (36'-1")
 x
 9.3 m (30'-7")

- Surface: 86.79 sq. m (934.22 sq. ft.)
- Perimeter: 35.06 m (115'-0")

MÉTHODES D'INSTALLATION

INSTALLATION METHODES

1

DANS LE BÉTON:

- Quantité de Sonotube de 12" Ø x 12' : 3

Béton :
 - 0.92 m. cu. (1.2 vge cu.)



1

CONCRETE:

- Quantity of Sonotube of 12" Ø x 12': 3

Concrete:
 - 0.92 cu. m. (1.2 cu. yd.)

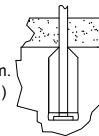

2

SYSTÈME AUTO-PORTANT:

Qté charpentes: 7
 Béton :
 - 0 m. cu. (0 vge cu.)



2

FREE-STANDING SYSTEM

Frame QTY: 7
 Concrete:
 - 0 cu. m. (0 cu. yd.)



Attention :

AIRE DE CIRCULATION LIBRE:

Aire dégagée d'obstacle qui se prolonge sur au moins 1.8m (70.87") au delà de la zone de protection. Voir dessin pour les détails.

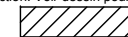

Warning:

NO-ENCROACHMENT ZONE

Obstacle-free zone extending at least 1.8m (70.87") beyond the protective surfacing zone. See drawing for details.



Ktodd-127

CAN/CSA-Z614-xx
 xx: Last Edition Published /
 Dernière édition publiée

Equipment Dimensions / Dimensions de l'équipement :
 7.3 m (24'-1") x 5.7 m (18'-7")

Capacity / Peut accueillir :
 up to 40 children / Jusqu'à 40 enfants

Recommended Ages / Âges recommandés :
 18 months to 5 years old
 18 mois à 5 ans

Fall Height /
 Hauteur de chute:
 2.59m (8'-6")

Approval date: 16-10-2014
 Rev: 00
 Initial: TLG

