

23 ch. Boom Lane, Unit/Unité E  
 Industrial Park/Parc industriel  
 Atholville, New/Nouveau-Brunswick  
 Canada, E3N 4E8  
 Tel/tél. : 1-888-212-1411/Fax/télec. : 1-888-789-0987  
 contact@kangoroo.com / www.kangoroo.com

### Colors / Couleurs

Post / Poteaux: Yellow/Jaune

Accent Color / Couleur complémentaire:  
 Spring Green/Vert printanier

1 Color panel / Panneaux 1 couleur: NA

2 colors panel / Panneaux 2 couleurs :  
 Red & White/Rouge et blanc

Slide / Glissoire: Spring Green/Vert printanier

Plastic Climbers / Grimpeur Plastique:  
 Spring Green/Vert printanier

Cable / Cable : NA

Roof / Toît : Red/Rouge

### Ktodd-126

Min. Protective Surface Required / Surface de protection min. requise :  
 6.9 m (22'-9") x 7.5 m (24'-7")

Equipment Dimensions / Dimensions de l'équipement :  
 3.3 m (10'-9") x 3.8 m (12'-7")

Approval date: 17/07/2014

Rev: 00

Initial: TLG

CAN/CSA-Z614-xx  
 xx: Last Edition Published/  
 Dernière édition publiée

Recommended Ages / Âges recommandés :  
 18 months to 5 years old / 18 mois à 5 ans

Capacity / Peut accueillir :  
 up to 20 children / Jusqu'à 20 enfants





23 ch. Boom Lane, Unit/Unité E  
 Industrial Park/Parc industriel  
 Atholville, New/Novveau-Brunswick  
 Canada, E3N 4E8  
 Tel/tél. : 1-888-212-1411/Fax/télééc. : 1-888-789-0987  
 go@kangoroo.com / www.kangoroo.com



<b>Ktodd-126</b>	Min. Protective Surface Required / Surface de protection min. requise : 6.9 m (22'-9") x 7.5 m (24'-7")	Equipment Dimensions / Dimensions de l'équipement : 3.3 m (10'-9") x 3.8 m (12'-7")	Approval date: 17/07/2014 Rev: 00 Initial: TLG
CAN/CSA-Z614-xx xx: Last Edition Published/ Dernière édition publiée	Recommended Ages / Âges recommandés : 18 months to 5 years old / 18 mois à 5 ans	Capacity / Peut accueillir : up to 20 children / Jusqu'à 20 enfants	



23 ch. Boom Lane, Unit/Unité E  
 Industrial Park/Parc industriel  
 Atholville, New/Novéau-Brunswick  
 Canada, E3N 4E8  
 Tel/tél. : 1-888-212-1411/Fax/télééc. : 1-888-789-0987  
 go@kangaroo.com / www.kangaroo.com

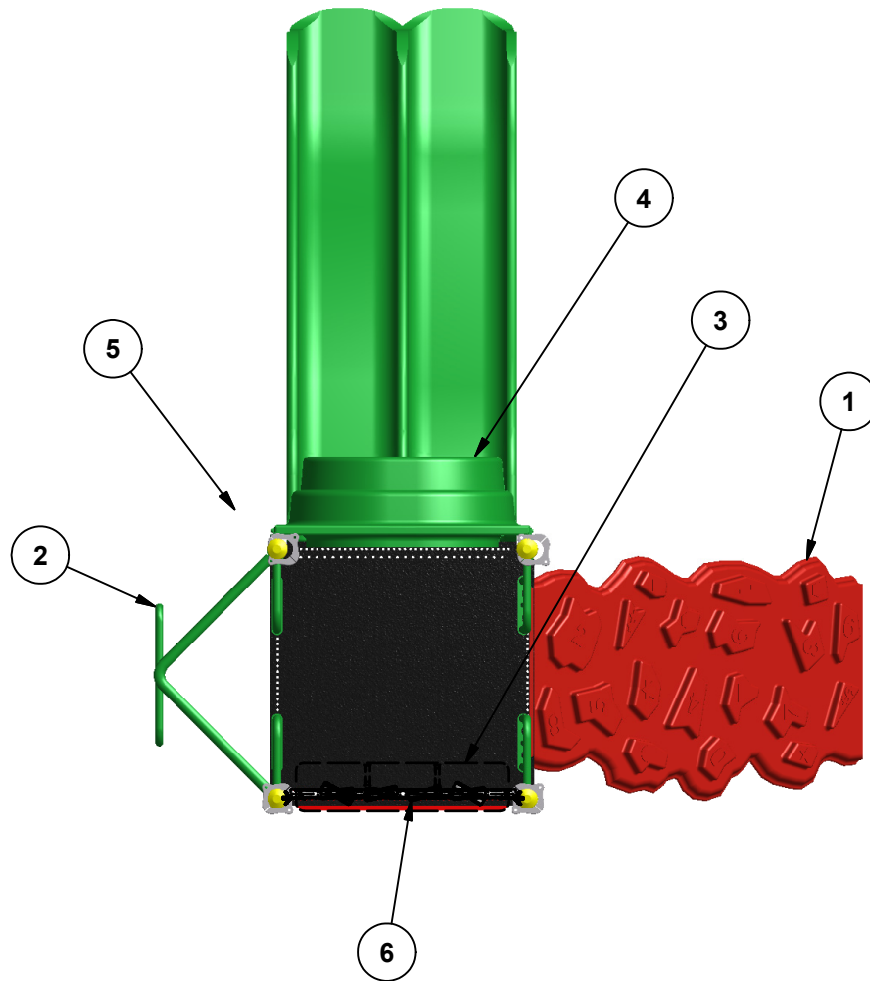

Legend / Légende

ITEM	QTY	Description	PART # / # PIECE
1	1	Fredrock Climber 48"/ Mur à grimper fredrock 48"	FS-FRC-48
2	1	Snake Pole 48"/ Échelle Serpentine 48"	SNK-PL-48
3	1	KG Counter Panel/Panneau comptoir KG	KG-COUNTER
4	1	Triple Rail Slide 48" / Glissoire double 48"	4TRS
5	1	Gable Roof / Toit à pignon	GABLEROOF
6	1	Kg Memory Game / Jeux de mémoire Kg	KG-MEMORY

**Ktodd-126**

CAN/CSA-Z614-xx  
 xx: Last Edition Published/  
 Dernière édition publiée

Min. Protective Surface Required / Surface de protection min. requise :  
 6.9 m (22'-9") x 7.5 m (24'-7")

Recommended Ages / Âges recommandés :  
 18 months to 5 years old / 18 mois à 5 ans

Equipment Dimensions / Dimensions de l'équipement :  
 3.3 m (10'-9") x 3.8 m (12'-7")

Capacity / Peut accueillir :  
 up to 20 children / Jusqu'à 20 enfants

Approval date: 17/07/2014  
 Rev: 00  
 Initial: TLG





23 ch. Boom Lane, Unit/Unité E, Industrial Park/Parc industriel  
 Atholville, New/Nouveau-Brunswick  
 Canada, E3N 4E8  
 Tel/tél. : 1-888-212-1411 - Fax/télééc. : 1-888-789-0987  
 contact@kangoroo.com / www.kangoroo.com

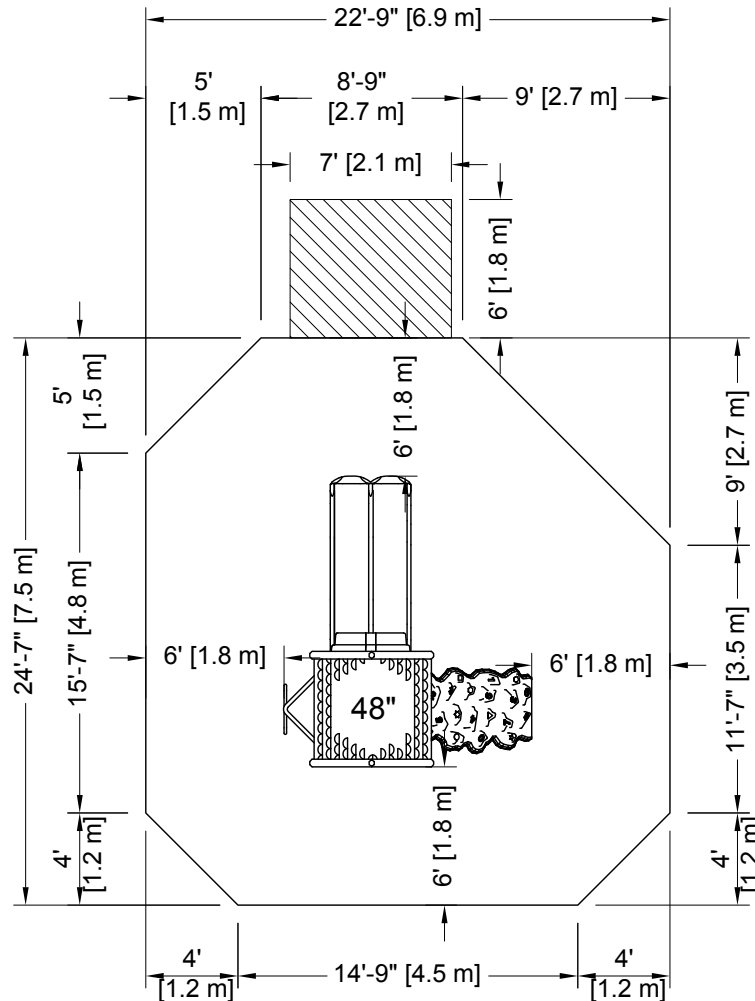

**PLATFORM HEIGHTS**  
**HAUTEURS DE PLATEFORME**

12" = 305MM	60" = 1524MM
24" = 609MM	72" = 1829MM
36" = 915MM	84" = 2134MM
48" = 1219MM	96" = 2438MM

**ZONE DE PROTECTION:**

Chaque équipement doit avoir une zone de protection constituée d'une surface sans obstacle qui se prolonge dans toutes les directions à partir du périmètre de l'équipement. Cette zone doit contenir un revêtement de surface (gravillon, sable, etc...) avec une capacité d'amortissement selon les normes CSA-Z614. Sauf avis contraire.

**Zone de protection minimum requise:**

6.9 m (22'-9")  
 x  
 7.5 m (24'-7")

- Aire : 45.62 m ca. (491.06 pi. ca.)
- Périmètre : 25.0 m (82'-0")

**PROTECTIVE SURFACING ZONE :**

Each equipment shall have a protective surfacing zone that consist of obstacle-free surfacing surrounding the equipment. This zone shall contain shock absorbing material (pea gravel, sand, etc...) that comply with CSA-Z614. Unless noted otherwise.

**Minimum Protective Surfacing Zone required:**

6.9 m (22'-9")  
 x  
 7.5 m (24'-7")

- Surface: 45.62 sq. m (491.06 sq. ft.)
- Perimeter: 25.0 m (82'-0")

**MÉTHODES D'INSTALLATION**

1

**DANS LE BÉTON:**

- Quantité de Sonotube de 12" Ø x 12" : 1

Béton :  
 - 0.31 m. cu. (0.4 vge cu.)



1

**CONCRETE:**

- Quantity of Sonotube of 12" Ø x 12": 1

Concrete:  
 - 0.31 cu. m. (0.4 cu. yd.)

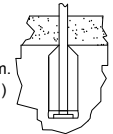

2

**SYSTÈME AUTO-PORTANT:**

Qté charpentes: 2  
 Béton :  
 - 0 m. cu. (0 vge cu.)

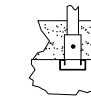

2

**FREE-STANDING SYSTEM**

Frame QTY: 2  
 Concrete:  
 - 0 cu. m. (0 cu. yd.)

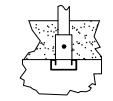

**Attention :**

**AIRE DE CIRCULATION LIBRE:**

Aire dégagée d'obstacle qui se prolonge sur au moins 1.8m (70.87") au delà de la zone de protection. Voir dessin pour les détails.

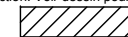

**Warning:**

**NO-ENCROACHMENT ZONE**

Obstacle-free zone extending at least 1.8m (70.87") beyond the protective surfacing zone. See drawing for details.



**Ktodd-126**

CAN/CSA-Z614-xx  
 xx: Last Edition Published /  
 Dernière édition publiée

Equipment Dimensions / Dimensions de l'équipement :  
 3.3 m (10'-9") x 3.8 m (12'-7")

Capacity / Peut accueillir :  
 up to 20 children / Jusqu'à 20 enfants

Recommended Ages / Âges recommandés :  
 18 months to 5 years old  
 18 mois à 5 ans

Fall Height /  
 Hauteur de chute:  
 2.29 m (7'-6")

Approval date: 17-07-2014  
 Rev: 00  
 Initial: TLG

