



23 ch. Boom Lane, Unit/Unité E
 Industrial Park/Parc industriel
 Atholville, New/Nouveau-Brunswick
 Canada, E3N 4E8
 Tel/tél. : 1-888-212-1411/Fax/télec. : 1-888-789-0987
 contact@kangoroo.com / www.kangoroo.com

Colors / Couleurs

Post / Poteaux: White/Blanc

Accent Color / Couleur complémentaire:
 Purple/Violet

1 Color panel / Panneaux 1 couleur: NA

2 colors panel / Panneaux 2 couleurs :
 Green & Tan/Vert et beige

Slide / Glissoire: Spring Green/Vert printanier

Plastic Climbers / Grimpeur Plastique:
 Spring Green/Vert printanier

Cable / Cable : NA

Roof / Toît : Purple/Violet

Ktodd-110M3

Min. Protective Surface Required / Surface de protection min. requise :
 9.3 m (30'-6") x 7.6 m (24'-11")

Equipment Dimensions / Dimensions de l'équipement :
 5.6 m (18'-6") x 3.9 m (12'-11")

Approval date: 16/01/2014

Rev: 00

Initial: TLG

CAN/CSA-Z614-xx
 xx: Last Edition Published/
 Dernière édition publiée

Recommended Ages / Âges recommandés :
 18 months to 5 years old / 18 mois à 5 ans

Capacity / Peut accueillir :
 up to 25 children / Jusqu'à 25 enfants





23 ch. Boom Lane, Unit/Unité E
 Industrial Park/Parc industriel
 Atholville, New/Nouveau-Brunswick
 Canada, E3N 4E8
 Tel/tél. : 1-888-212-1411/Fax/télééc. : 1-888-789-0987
 go@kangaroo.com / www.kangaroo.com



Ktodd-110M3	Min. Protective Surface Required / Surface de protection min. requise : 9.3 m (30'-6") x 7.6 m (24'-11")	Equipment Dimensions / Dimensions de l'équipement : 5.6 m (18'-6") x 3.9 m (12'-11")	Approval date: 16/01/2014 Rev: 00 Initial: TLG
CAN/CSA-Z614-xx xx: Last Edition Published/ Dernière édition publiée	Recommended Ages / Âges recommandés : 18 months to 5 years old / 18 mois à 5 ans	Capacity / Peut accueillir : up to 25 children / Jusqu'à 25 enfants	



23 ch. Boom Lane, Unit/Unité E
 Industrial Park/Parc industriel
 Atholville, New/Nouveau-Brunswick
 Canada, E3N 4E8
 Tel/tél. : 1-888-212-1411/Fax/télééc. : 1-888-789-0987
 go@kangoroo.com / www.kangoroo.com

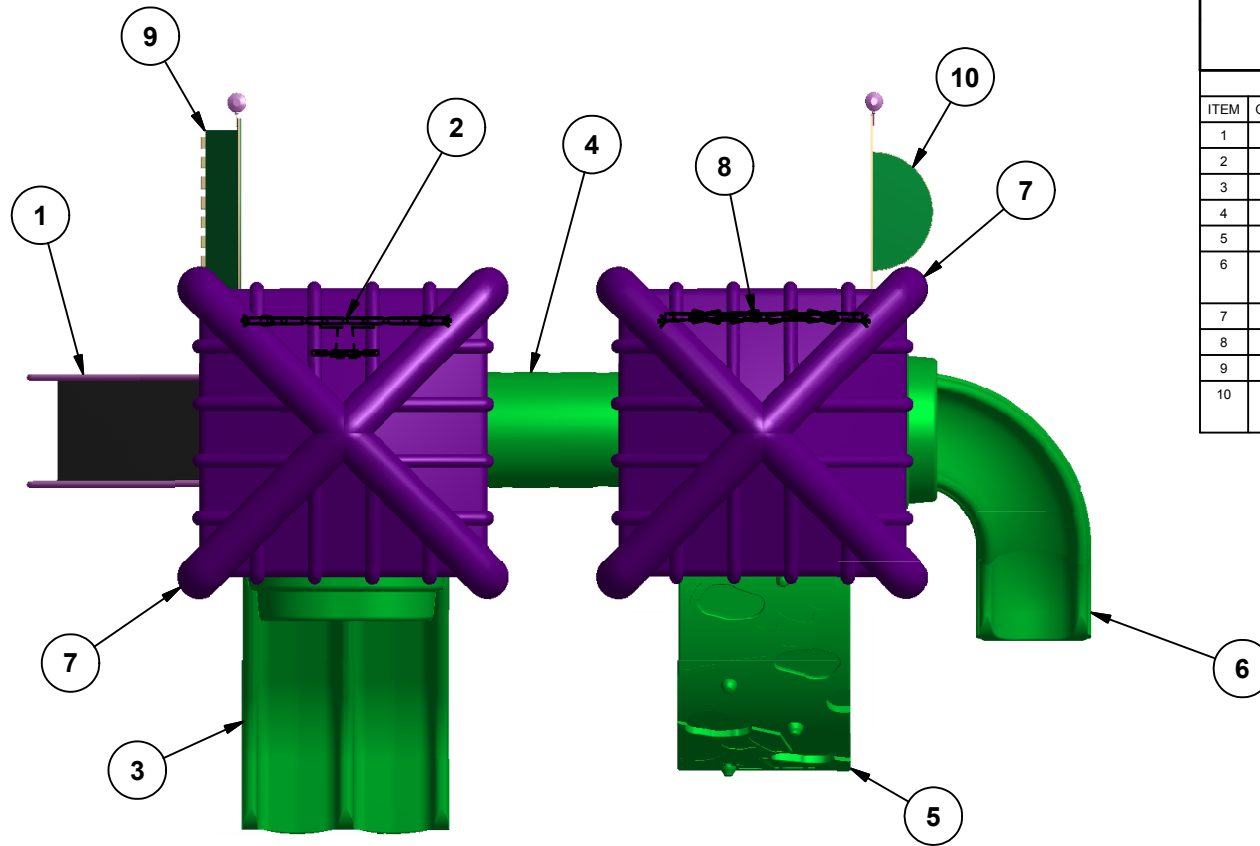

Legend / Légende

ITEM	QTY	Description	PART # / # PIECE
1	1	Stairs 36"/Escalier 36"	STAIR-36
2	1	Car Panel / Panneau Auto	AC-STW
3	1	Triple Rail Slide 36"/Glissoire double 36"	3TRS
4	1	Tunnel / Tunnel	DTD-TUN-24Dia
5	1	Bedrock Climber / Mur à grimper bedrock	BRC
6	1	90° Curved slide 36"/ Glissoire courbée 90°, 36"	3CURVED,N
7	2	Pyramid Roof/Toit pyramide	PYRA-RF
8	1	Kg Memory Game / Jeux de mémoire Kg	KG-MEMORY
9	1	Kg Piano Panel / Kg Piano	KG-PIANO
10	1	KG Ice Cream Shop/ Comptoir crème glacée KG	KG-ICE-CRMSHP

Ktodd-110M3

Min. Protective Surface Required / Surface de protection min. requise :
 9.3 m (30'-6") x 7.6 m (24'-11")

Equipment Dimensions / Dimensions de l'équipement :
 5.6 m (18'-6") x 3.9 m (12'-11")

Approval date: 16/01/2014

Rev: 00

Initial: TLG

CAN/CSA-Z614-xx
 xx: Last Edition Published/
 Dernière édition publiée

Recommended Ages / Âges recommandés :
 18 months to 5 years old / 18 mois à 5 ans

Capacity / Peut accueillir :
 up to 25 children / Jusqu'à 25 enfants





23 ch. Boom Lane, Unit/Unité E, Industrial Park/Parc industriel
 Atholville, New/Nouveau-Brunswick
 Canada, E3N 4E8
 Tel/tél. : 1-888-212-1411 - Fax/télééc. : 1-888-789-0987
 contact@kangoroo.com / www.kangoroo.com

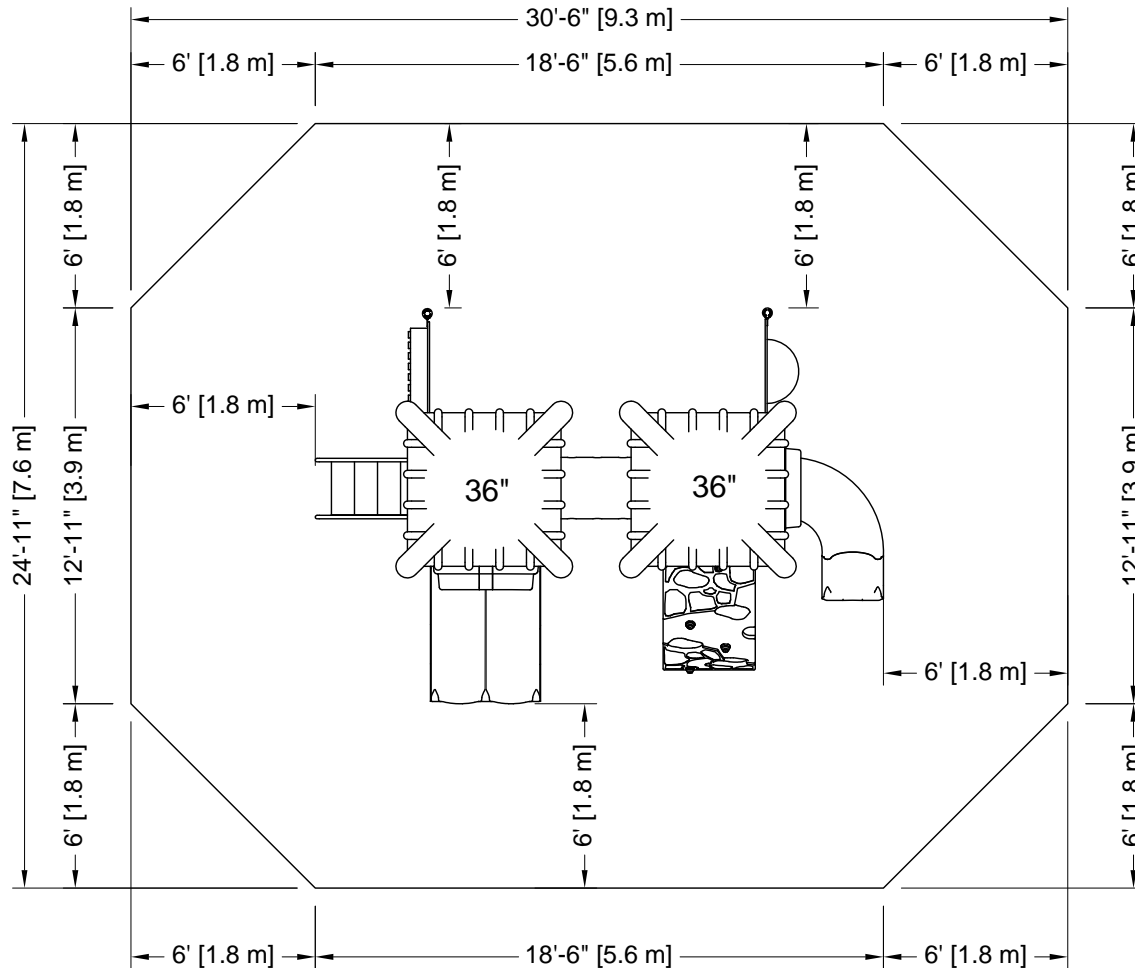

PLATFORM HEIGHTS
 HAUTEURS DE PLATEFORME

12" = 305MM	60" = 1524MM
24" = 609MM	72" = 1829MM
36" = 915MM	84" = 2134MM
48" = 1219MM	96" = 2438MM

ZONE DE PROTECTION:

Chaque équipement doit avoir une zone de protection constituée d'une surface sans obstacle qui se prolonge dans toutes les directions à partir du périmètre de l'équipement. Cette zone doit contenir un revêtement de surface (gravillon, sable, etc...) avec une capacité d'amortissement selon les normes CSA-Z614. Sauf avis contraire.

Zone de protection minimum requise:

9.3 m (30'-6")
 x
 7.6 m (24'-11")

- Aire : 63.79 m ca. (686.67 pi. ca.)
- Périmètre : 29.56 m (97'-0")

PROTECTIVE SURFACING ZONE :

Each equipment shall have a protective surfacing zone that consist of obstacle-free surfacing surrounding the equipment. This zone shall contain shock absorbing materi: (pea gravel, sand, etc...) that comply with CSA-Z614. Unless noted otherwise.

Minimum Protective Surfacing Zone required:

9.3 m (30'-6")
 x
 7.6 m (24'-11")

- Surface: 63.79 sq. m (686.67 sq. ft.)
- Perimeter: 29.56 m (97'-0")

MÉTHODES D'INSTALLATION

1

DANS LE BÉTON:

- Quantité de Sonotube de 12" Ø x 12" : 2

Béton :
 - 0.76 m. cu.
 (1.0 vge cu.)



1

CONCRETE:

- Quantity of Sonotube of 12" Ø x 12": 2

Concrete:
 - 0.76 cu. m.
 (1.0 cu. yd.)

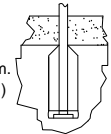

2

SYSTÈME AUTO-PORTANT:

Qté charpentes: 4

Béton :
 - 0.15 m. cu.
 (0.2 vge cu.)

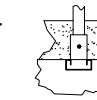

2

FREE-STANDING SYSTEM

Frame QTY: 4

Concrete:
 - 0.15 cu. m.
 (0.2 cu. yd.)

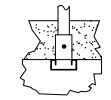

**Attention :
 AIRE DE CIRCULATION LIBRE:**

Aire dégagée d'obstacle qui se prolonge sur au moins 1.8m (70.87") au delà de la zone de protection. Voir dessin pour les détails.

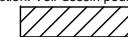

Warning:

NO-ENCROACHMENT ZONE

Obstacle-free zone extending at least 1.8m (70.87") beyond the protective surfacing zone. See drawing for details.



Ktodd-110M3

CAN/CSA-Z614-xx
 xx: Last Edition Published /
 Dernière édition publiée

Equipment Dimensions / Dimensions de l'équipement :
 5.6 m (18'-6") x 3.9 m (12'-11")

Capacity / Peut accueillir :
 up to 25 children / Jusqu'à 25 enfants

Recommended Ages / Âges recommandés :
 18 months to 5 years old
 18 mois à 5 ans

Fall Height /
 Hauteur de chute:
 1.98 m (6'-6")

Approval date: 16-01-2014
 Rev: 00
 Initial: TLG

