



23 ch. Boom Lane, Unit/Unité E Industrial
 Park/Parc industriel Atholville, New/Nouveau-
 Brunswick Canada, E3N 4E8
 Tel/tél. : 1-888-212-1411/Fax/télé. : 1-888-
 789-0987 www.kangaroo.com



KTH-111FN	Min. Protective Surface Required / Surface de protection min. requise 14.1m (46'-3") x 14.4m (47'-4")	Equipment Dimensions / Dimensions de l'équipement : 10.7m (35'-2") x 10.4m (34'-3")	Approval date: 10-06-21 Rev: 00
CAN/CSA-Z614	Recommended Ages / Âges recommandés : 18 months to 12 years old / 18 mois à 12 ans	Capacity / Peut accueillir : up to 30 children / Jusqu'à 30 enfants	Initial: AK



23 ch. Boom Lane, Unit/Unité E Industrial
Park/Parc industriel Atholville, New/Nouveau-
Brunswick Canada, E3N 4E8
Tel/tél. : 1-888-212-1411/Fax/télé. : 1-888-
789-0987 www.kangaroo.com



KTH-111FN

Min. Protective Surface Required / Surface de protection min. requise
14.1m (46'-3") x 14.4m (47'-4")

Equipment Dimensions / Dimensions de l'équipement :
10.7m (35'-2") x 10.4m (34'-3")

Approval date: 10-06-21

Rev: 00

Initial: AK

CAN/CSA-Z614

Recommended Ages / Âges recommandés :
18 months to 12 years old / 18 mois à 12 ans

Capacity / Peut accueillir : up to 30 children / Jusqu'à 30 enfants



23 ch. Boom Lane, Unit/Unité E Industrial
 Park/Parc industriel Atholville, New/Nouveau-
 Brunswick Canada, E3N 4E8
 Tel/tél. : 1-888-212-1411/Fax/télé. : 1-888-
 789-0987 www.kangoroo.com

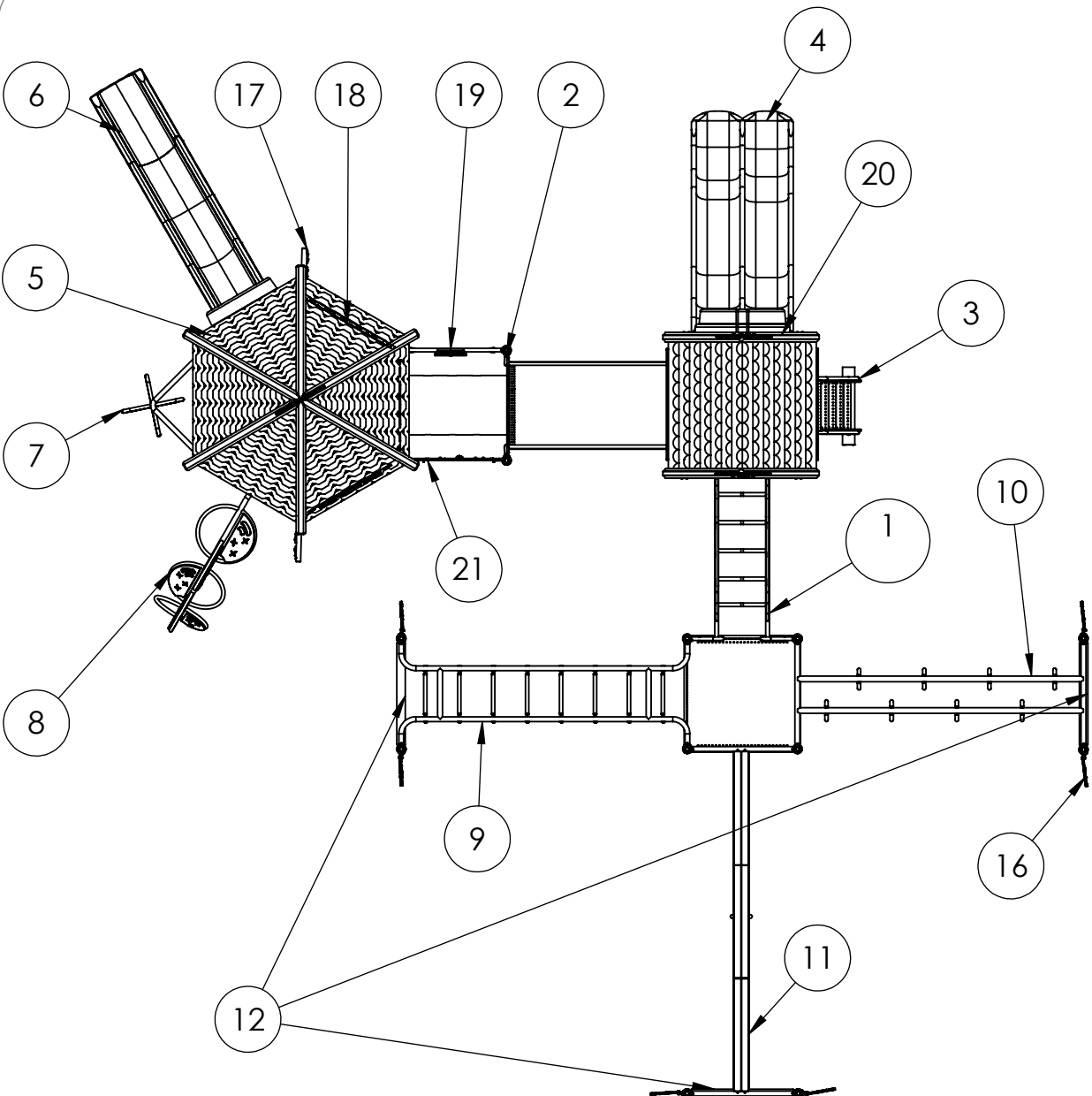

ITEM NO.	PART NUMBER	DESCRIPTION	QTY.
1	CAT-CL-DTD-36Hx72L_00	Catterpillar climber-36"	1
2	ARCH BRIDGE	Bri-Arch-48"	1
3	STEP LADDER-enclosed-48	PF-LA-GD-48"	1
4	TRIPLE RAIL SLIDE 48	SLD-2-003-48"	1
5	HEX ROOF	Hexagon Roof	1
6	WAVY DOUBLE WALL SLIDE 60	Wavy Double Wall Slide 60" / Glissoire simple en vague 60"	1
7	CROSS SNAKE POLE 60	CL-CR-SNK-PL-60"	1
8	ORION-LINK-60	CL-LK-ARC-60"	1
9	SS-305_00	Suspended Ladder	1
10	SS-306	Upper Double Ring Ladder	1
11	SS-309_00	Upper Track Ride	1
12	PFS-3x41_00.0036	Deck	3
13	tunnel-PTP-24-45.5L-hdpe	tunnel- Ø24"	1
14	KG-TTT	Tic-Tak-Toe	1
15	RISSER	Risser-12"	1
16	Feather-deco-post-ass_00.ipt		6
17	Dream-catcher-deco		2
18	KG-MEMORY-NATURE_01.0002	KG-Memory Pannel	1
19	WHEEL		1
20	Gable-Roof-spi		1
21	KG-AGEAR-W-bracket		1
35	Hex-Roof-Fn-Deco_00	Roof Side Decoration/Décoration	8
36	Hex-Roof-fn-2sides_00	Rev: 00	3
37	Eagle-Ass-right_00	Initial: AK	2
38	Eagle-Ass-lft_00		2

KTH-111FN

Min. Protective Surface Required / Surface de protection min. requise
 14.1m (46'-3") x 14.4m (47'-4")

Equipment Dimensions / Dimensions de l'équipement :
 10.7m (35'-2") x 10.4m (34'-3")

CAN/CSA-Z614

Recommended Ages / Âges recommandés :
 18 months to 12 years old / 18 mois à 12 ans

Capacity / Peut accueillir : up to 50 children / jusqu'à 50 enfants

Approval date: 10-06-21

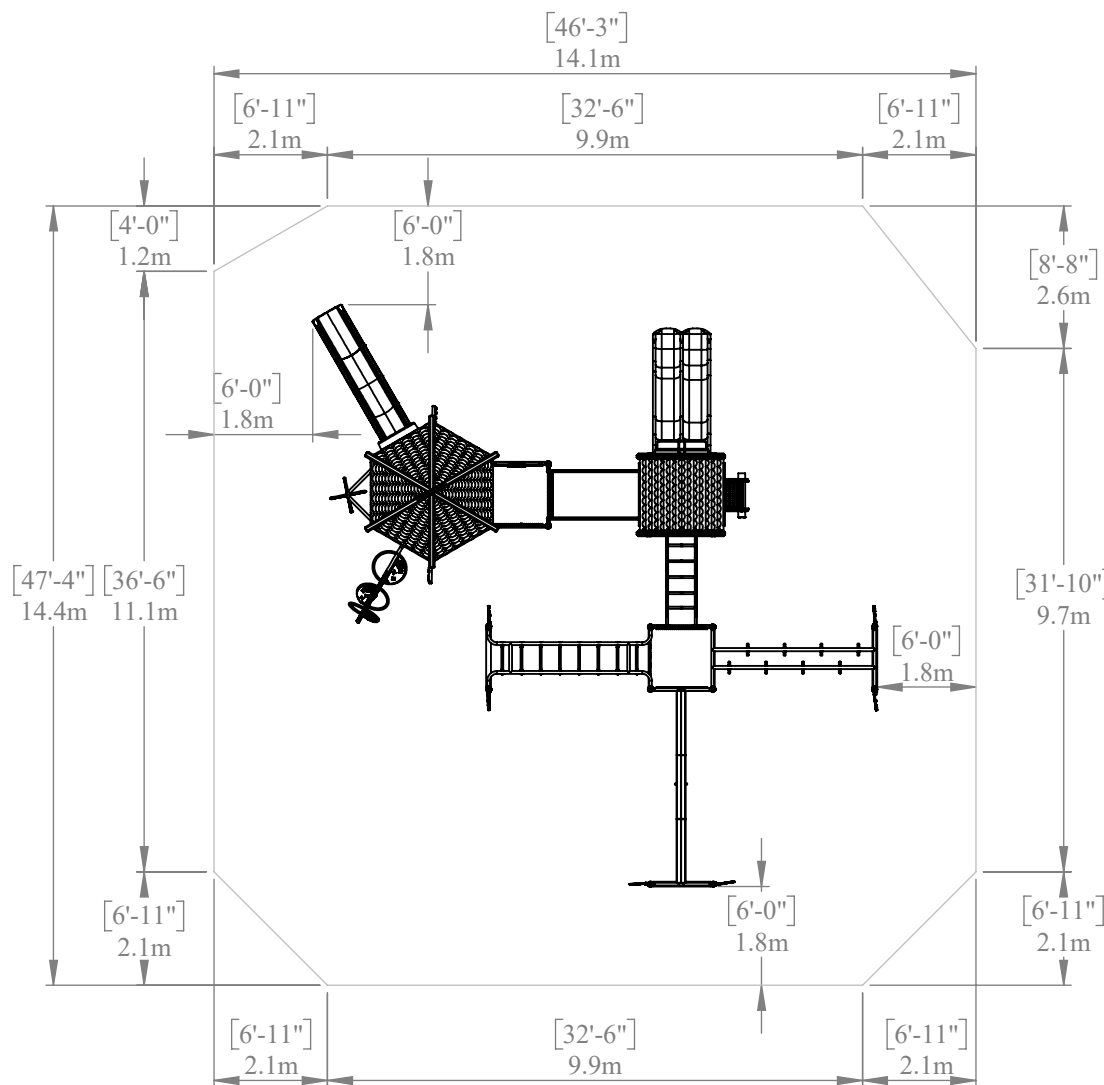

PLATFORM HEIGHTS
 HAUTEURS DE PLATEFORME

12" = 305MM	24" = 609MM
36" = 915MM	48" = 1219MM
60" = 1524MM	72" = 1829MM
84" = 2134MM	96" = 2438MM



ZONE DE PROTECTION:

Chaque équipement doit avoir une zone de protection constituée d'une surface sans obstacle qui se prolonge dans toutes les directions à partir du périmètre de l'équipement. Cette zone doit contenir un revêtement de surface (gravillon, sable, etc...) avec une capacité d'amortissement selon les normes CSA-Z614. Sauf avis contraire.

Zone de protection **minimum** requise:
 14.1m (46'-3")
 x
 14.4m (47'-4")
 - Surface: 203.04 sq. m (2185.5 sq. ft.)
 - Perimeter: 57m (187'-0")

PROTECTIVE SURFACING ZONE :

Each equipment shall have a protective surfacing zone that consist of obstacle-free surfacing surrounding the equipment. This zone shall contain shock absorbing material (pea gravel, sand, etc...) that comply with CSA-Z614. Unless noted otherwise.

Minimum Protective Surfacing Zone required:
 14.1m (46'-3")
 x
 14.4m (47'-4")
 - Surface: 203.04 sq. m (2185.5 sq. ft.)
 - Perimeter: 57m (187'-0")

MÉTHODES D'INSTALLATION

①

DANS LE BÉTON:

- Quantité de Sonotube de 12" Ø x 12' :5

Béton:
 -2.35m.cu.
 (3.07vge.cu.)



INSTALLATION METHODS

①

CONCRETE

-Quantity of sonotube of 12"Øx12':5

CONCRETE
 -2.35 cu.m.
 (3.074 cu.yd.)



②

SYSTÈME AUTO-PORTANT:

Qté charpentes: 12

Béton :
 - 0.05 m. cu.
 (0.07vge cu.)



②

FREE-STANDING SYSTEM:

Frame QTY: 12

Concrete:
 - 0.05 cu. m.
 -(0.07 cu. yd.)



Attention :

AIRE DE CIRCULATION LIBRE:

Aire dégagée d'obstacle qui se prolonge sur au moins 1.8m (70.87") au delà de la zone de protection. Voir dessin pour les détails.



Warning:

NO-ENCROACHMENT ZONE:

Obstacle-free zone extending at least 1.8m (70.87") beyond the protective surfacing zone. See drawing for details.



KTH-111FN

Min. Protective Surface Required / Surface de protection min. requise
 14.1m (46'-3") x 14.4m (47'-4")

Equipment Dimensions / Dimensions de l'équipement : 10.7m (35'-2") x 10.4m (34'-3")

Fall Height / Hauteur de chute:
 2.86 m (9'-4")

Approval date: 10-06-21
 Rev: 00
 Initial: AK

CAN/CSA-Z614

Recommended Ages / Âges recommandés :
 18 months to 12 years old / 18 mois à 12 ans

Capacity / Peut accueillir : up to 30 children / Jusqu'à 30 enfants