

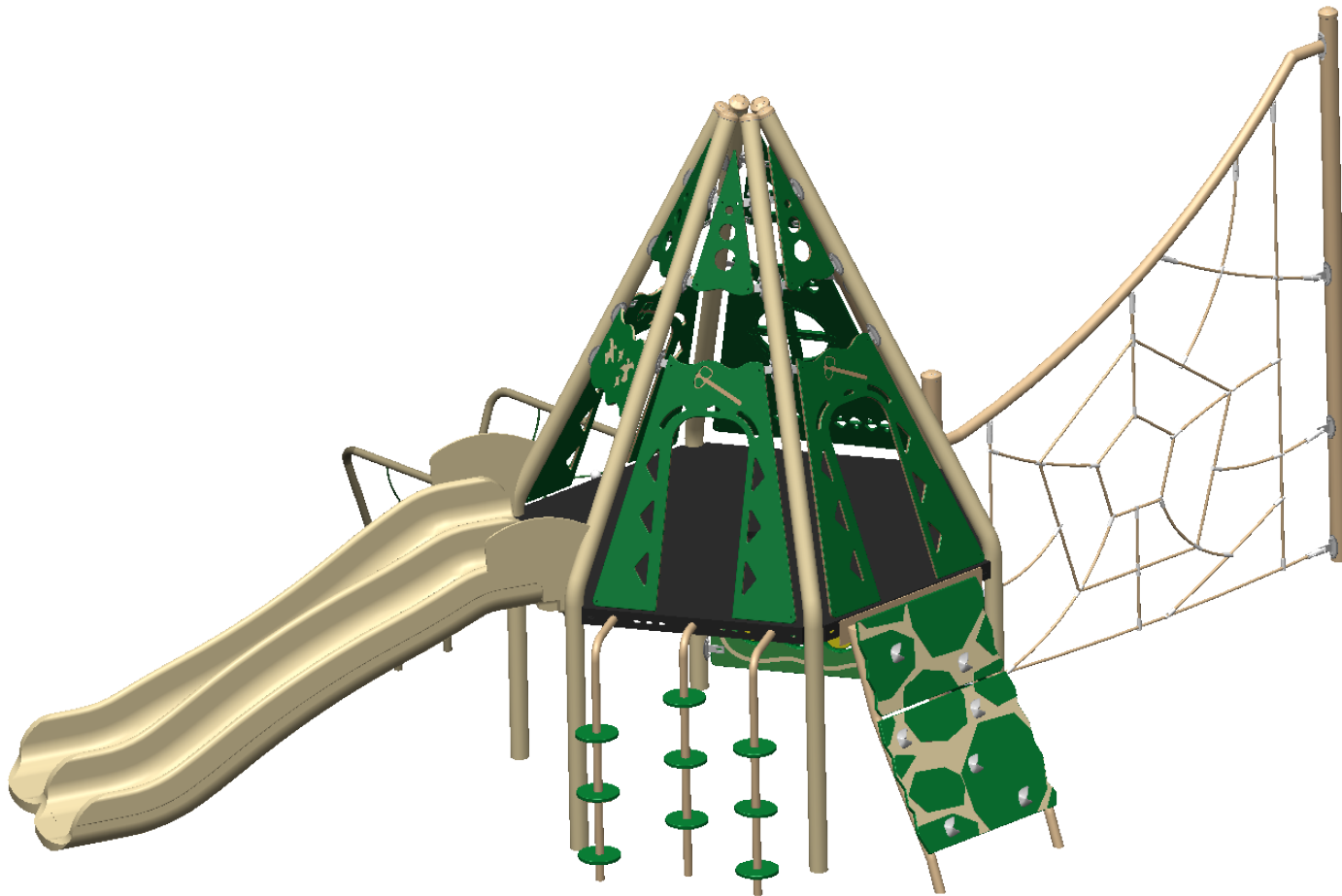

23 ch. Boom Lane, Unit/Unité E Industrial Park/Parc  
 industriel Atholville, New/Nouveau-Brunswick  
 Canada, E3N 4E8  
 Tel/tél. : 1-888-212-1411/Fax/télé. : 1-888-789-0987  
 www.kangoroo.com



**Spider web peak ropes will be replaced with chains**

**Ktheme-108 Fn M2**

Min. Protective Surface Required / Surface de protection min. requise  
 7.0 m (22'-10") x 3.9 m (12'-9")

Equipment Dimensions / Dimensions de l'équipement :  
 7.0 m (22'-10") x 3.9 m (12'-9")

Approval date:

Rev: 01

CAN/CSA-Z614

Recommended Ages / Âges recommandés :  
 up to 25 children / Jusqu'à 25 enfants

Capacity / Peut accueillir : up to 30 children / Jusqu'à 30 enfants

Initial:



23 ch. Boom Lane, Unit/Unité E Industrial Park/Parc  
 industriel Atholville, New/Nouveau-Brunswick  
 Canada, E3N 4E8  
 Tel/tél. : 1-888-212-1411/Fax/télé. : 1-888-789-0987  
 www.kangaroo.com

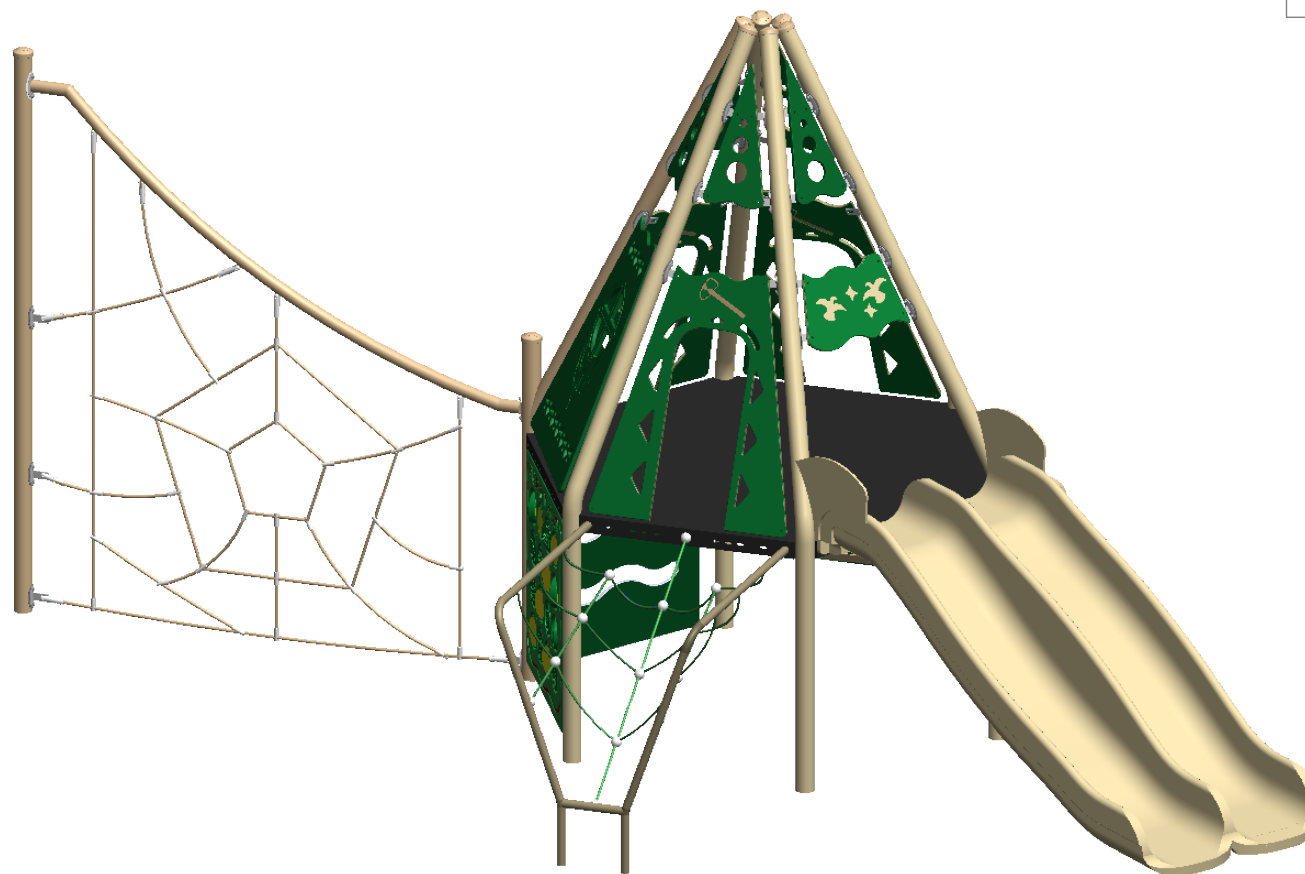

**Ktheme-108 Fn M2**

Min. Protective Surface Required / Surface de protection min. requise  
 7.0 m (22'-10") x 3.9 m (12'-9")

Equipment Dimensions / Dimensions de l'équipement :  
 7.0 m (22'-10") x 3.9 m (12'-9")

Approval date:

Rev: 01

CAN/CSA-Z614

Recommended Ages / Âges recommandés :  
 up to 25 children / Jusqu'à 25 enfants

Capacity / Peut accueillir : up to 30 children / Jusqu'à 30 enfants

Initial:



23 ch. Boom Lane, Unit/Unité E Industrial Park/Parc  
industriel Atholville, New/Nouveau-Brunswick  
Canada, E3N 4E8  
Tel/tél. : 1-888-212-1411/Fax/télé. : 1-888-789-0987  
www.kangaroo.com

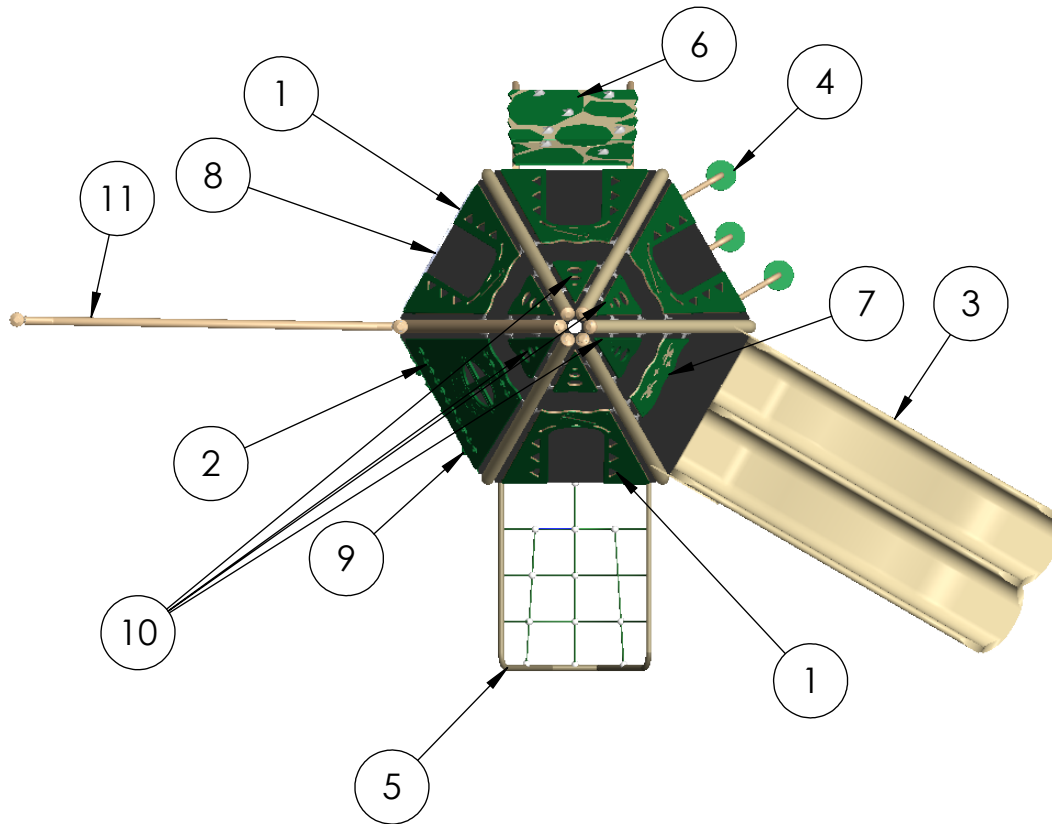

| ITEM NO | QTY | DESCRIPTION  | PART / PIECE  |
|---------|-----|--|---------------|
| 1       | 1   | Fn Component Door Panel / Panneau d'entrée de composantes Fn | Kth-FN-WALL   |
| 2       | 4   | Fn Dream Catcher Wall Panel / Panneau capteur de rêves Fn    | Kth-FN-DOOR   |
| 3       | 1   | Triple Rail Slide 48" / Glissoire double 48"                 | 4TRS          |
| 4       | 1   | Pommel Climber 48" / Grimpeur a pommeaux 48"                 | POM-CL-48     |
| 5       | 1   | Funnel climbing Net 48" / Fillet entenoir 48"                | CL-FUN-48     |
| 6       | 2   | Rock Challenge Climber 48" / Cap de roche 48"                | KTHEME-FN-TOP |
| 7       | 1   | Fn Slide device / Dispositif de glissoire Fn                 | FN-LP-48      |
| 8       | 1   | Fn Ladder Panel / Panneau échelle Fn                         | SS-454        |
| 9       | 1   | KG memory game / Jeux de mémoire KG                          | AC-TTT        |
| 10      | 6   | Roof DEco Fn / Décoration de toit Fn                         | FS-STP-48     |
| 11      | 1   | Spider Web Peak/Toile d'araignée en pointe                   | FS-RCK-CH-48  |

### Kthème-108 Fn M2

Min. Protective Surface Required / Surface de protection min. requise  
7.0 m (22'-10") x 3.9 m (12'-9")

Equipment Dimensions / Dimensions de l'équipement :  
7.0 m (22'-10") x 3.9 m (12'-9")

Approval date:  
Rev: 01  
Initial:

CAN/CSA-Z614

Recommended Ages / Âges recommandés :  
up to 25 children / Jusqu'à 25 enfants





Capacity / Peut accueillir : up to 30 children / Jusqu'à 30 enfants

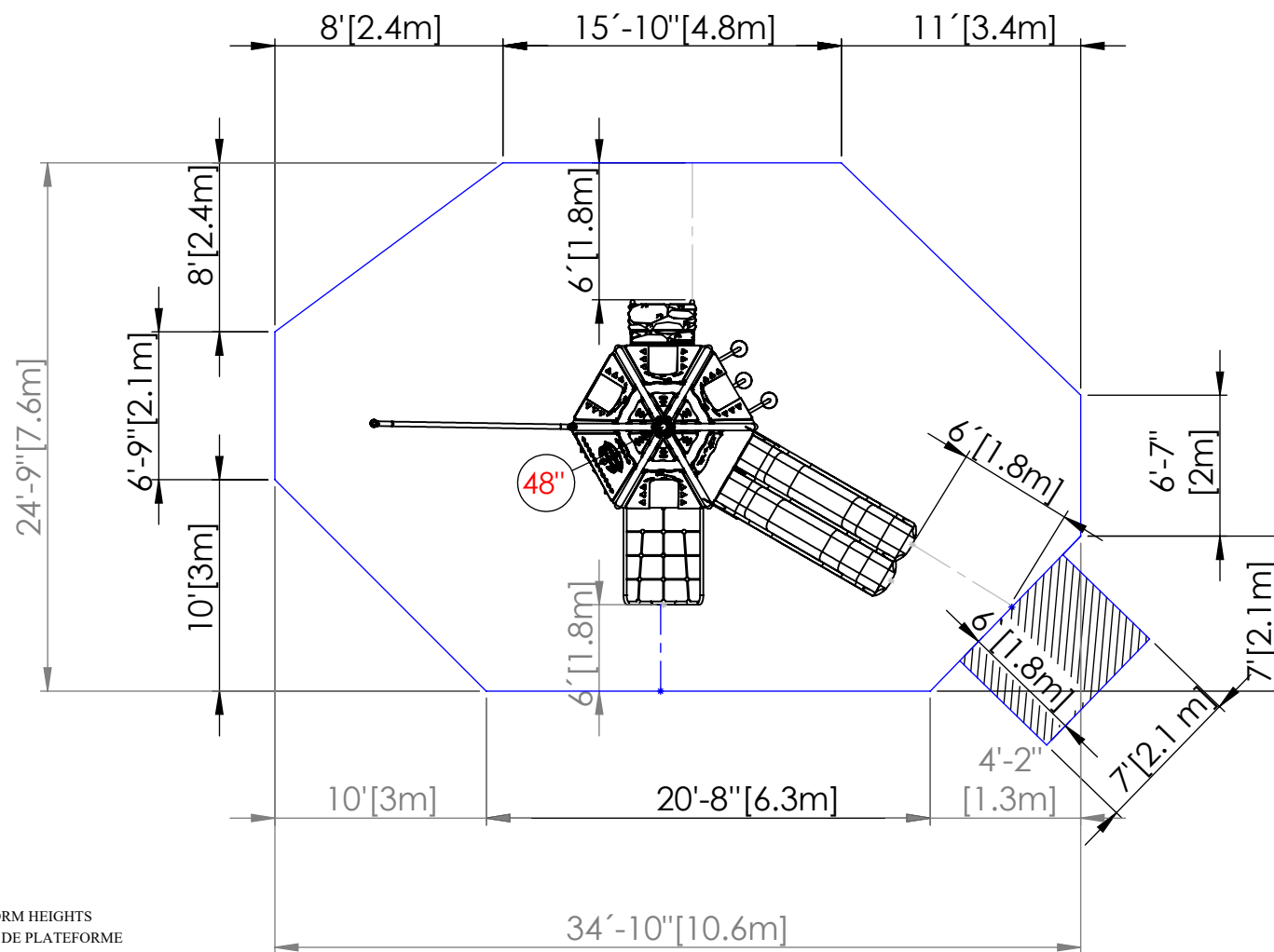

23 ch. Boom Lane, Unit/Unité E Industrial Park/Parc industriel  
 Atholville, New/Nouveau-Brunswick Canada, E3N 4E8  
 Tel/tél. : 1-888-212-1411/Fax/télé. : 1-888-789-0987  
 www.kangoroo.com

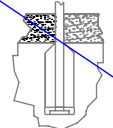
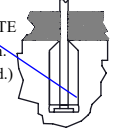

PLATFORM HEIGHTS  
 HAUTEURS DE PLATEFORME  
 12" = 305MM 24" = 609MM  
 36" = 915MM 48" = 1219MM  
 60" = 1524MM 72" = 1829MM  
 84" = 2134MM 96" = 2438MM

|  |  |
|--|--|
| <p><b>ZONE DE PROTECTION:</b><br/>         Chaque équipement doit avoir une zone de protection constituée d'une surface sans obstacle qui se prolonge dans toutes les directions à partir du périmètre de l'équipement. Cette zone doit contenir un revêtement de surface (gravillon, sable, etc...) avec une capacité d'amortissement selon les normes CSA-Z614.<br/>         Sauf avis contraire.<br/>         Zone de protection <u>minimum</u> requise:<br/>         14.1 m (46'-1.6")<br/>         x<br/>         9.0 m (29'-7.5")<br/>         - Surface: 126.9 sq. m (1365.9 sq. ft.)<br/>         - Perimeter: 46.2m (151'-6")</p> | <p><b>PROTECTIVE SURFACING ZONE:</b><br/>         Each equipment shall have a protective surfacing zone that consist of obstacle-free surfacing surrounding the equipment. This zone shall contain shock absorbing material (pea gravel, sand, etc...) that comply with CSA-Z614. Unless noted otherwise.<br/>         Minimum<br/>         Protective Surfacing Zone required:<br/>         14.1 m (46'-1.6")<br/>         x<br/>         9.0 m (29'-7.5")<br/>         - Surface: 126.9 sq. m (1365.9 sq. ft.)<br/>         - Perimeter: 46.2m (151'-6")</p> |
| <p><b>MÉTHODES D'INSTALLATION</b><br/> <del>1</del><br/> <b>DANS LE BÉTON:</b><br/>         - Quantité de Sonotube de 12" Ø x 12' : 3<br/>         Béton:<br/>         -1.5 m.cu. (1.96 vge.cu.)</p>    | <p><b>INSTALLATION METHODS</b><br/> <del>1</del><br/> <b>CONCRETE</b><br/>         -Quantity of sonotube of 12"Øx12':3<br/>         CONCRETE<br/>         -1.5 cu.m. (1.96cu.yd.)</p>   |
| <p><b>2</b><br/> <b>SYSTÈME AUTO-PORTANT:</b><br/>         Qté charpentes: <b>4</b><br/>         Béton :<br/>         - 0.0 m. cu. (0.0 vge cu.)</p>    | <p><b>2</b><br/> <b>FREE-STANDING SYSTEM:</b><br/>         Frame QTY: <b>4</b><br/>         Concrete:<br/>         - 0.0 cu. m. (-0.0 cu. yd.)</p>    |
| <p><b>Attention :</b><br/> <b>AIRE DE CIRCULATION LIBRE:</b><br/>         Aire dégagée d'obstacle qui se prolonge sur au moins 1.8m (70.87") au delà de la zone de protection. Voir dessin pour les détails.</p>    | <p><b>Warning:</b><br/> <b>NO-ENCROACHMENT ZONE:</b><br/>         Obstacle-free zone extending at least 1.8m (70.87") beyond the protective surfacing zone. See drawing for details.</p>    |

|                                |   |  |   |  |
|--------------------------------|---|--|---|--|
| <p><b>Kthème-108 Fn M2</b></p> | <p>Min. Protective Surface Required / Surface de protection min. requise</p>                  | <p>Equipment Dimensions / Dimensions de l'équipement :</p>                 | <p>Fall Height / Hauteur de chute:<br/>2.29 m (7'-6")</p> | <p>Approval date: 26-08-20<br/>Rev: 01<br/>Initial: AK</p> |
| <p>CAN/CSA-Z614</p>            | <p>Recommended Ages / Âges recommandés :<br/>18 months to 12 years old / 18 mois à 12 ans</p> | <p>Capacity / Peut accueillir : up to 30 children / Jusqu'à 30 enfants</p> |   |  |