

23 ch. Boom Lane, Unit/Unité E, Industrial Park/Parc industriel  
 Atholville, New-Brunswick, Canada, E3N 4E8  
 Tel/tél. : 1-888-212-1411, Fax. : 1-888-789-0987  
 contact@kangoroo.com / www.kangoroo.com



### Colors / Couleurs

Post / Poteaux: White/Blanc

Accent Color / Couleur complémentaire:  
 Blue & Red/Rouge et bleu

1 Color panel / Panneaux 1 couleur: Red/rouge

2 colors panel / Panneaux 2 couleurs :  
 Blue & White/Rouge et blanc

Slide / Glissoire: Red/Rouge

Plastic Climbers / Grimpeur Plastique:  
 NA

Cable / Cable : NA

Roof / Toit : NA

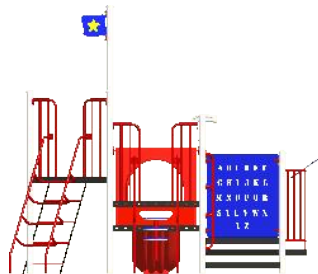

### Ktheme-105BtM2

Min. Protective Surface Required / Surface de protection min. requise :  
 9.3 m (30'-7") x 8.6 m (28'-3")

Equipment Dimensions / Dimensions de l'équipement :  
 4.9 m (16'-3") x 5.7 m (18'-7")

Approval date: 13/04/2017

Rev: 00

Initial: AMR

CAN/CSA-Z614-xx  
 xx: Last Edition Published/  
 Dernière édition publiée

Recommended Ages / Âges recommandés :  
 18 months to 5 years old / 18 mois à 5 ans

Capacity / Peut accueillir :  
 up to 25 children / Jusqu'à 25 enfants





23 ch. Boom Lane, Unit/Unité E  
 Industrial Park/Parc industriel  
 Atholville, New/Nouveau-Brunswick  
 Canada, E3N 4E8  
 Tel/tél. : 1-888-212-1411/Fax/télééc. : 1-888-789-0987  
 www.kangoroo.com

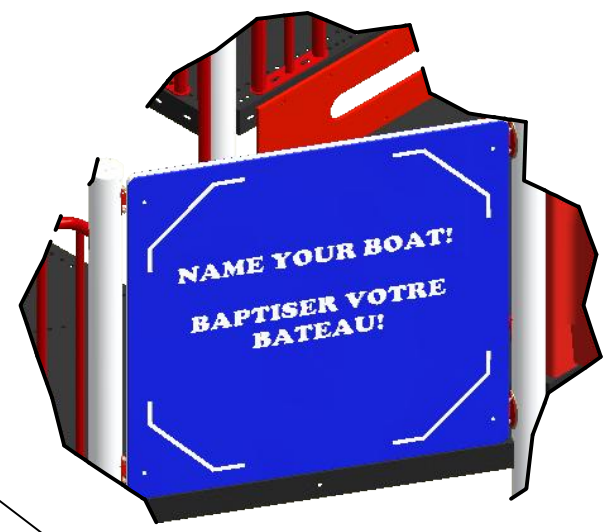

DETAIL A

<b>Kthème-105BtM2</b>	Min. Protective Surface Required / Surface de protection min. requise : 9.3 m (30'-7") x 8.6 m (28'-3")	Equipment Dimensions / Dimensions de l'équipement : 4.9 m (16'-3") x 5.7 m (18'-7")	Approval date: 13/04/2017 Rev: 00 Initial: AMR
CAN/CSA-Z614-xx xx: Last Edition Published/ Dernière édition publiée	Recommended Ages / Âges recommandés : 18 months to 5 years old / 18 mois à 5 ans	Capacity / Peut accueillir : up to 25 children / Jusqu'à 25 enfants	



23 ch. Boom Lane, Unit/Unité E  
 Industrial Park/Parc industriel  
 Atholville, New/Nouveau-Brunswick  
 Canada, E3N 4E8  
 Tel/tél. : 1-888-212-1411/Fax/télééc. : 1-888-789-0987  
 www.kangoroo.com

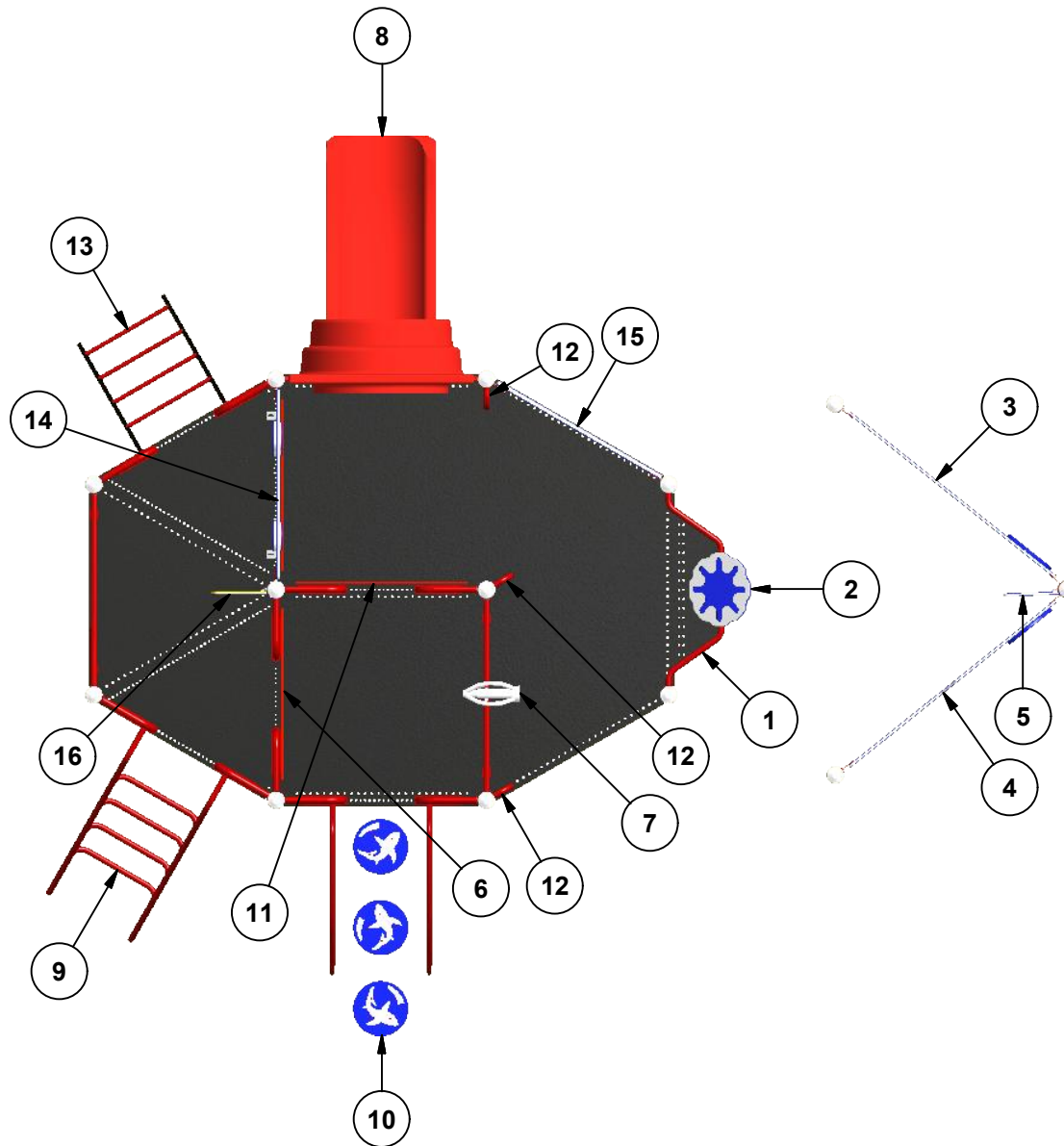

Legend / Légende

ITEM	QTY	Description	PART # / # PIECE
1	1	Balcony Deck / Balcon	PF-BD
2	1	Small Ship Wheel / Petit gouvernail	SHIP-WHEEL
3	1	KG Right Boat Bow/Coque de bateau droite KG	KG-RGHT-BT-BOW
4	1	KG Left Boat Bow/Coque de bateau gauche KG	KG-LFT-BT-BOW
5	1	Nautica Flague / Drapeau nautique	FLAGUE
6	2	Riser 12"/contre-marche 12"	Riser-12
7	1	Telescope Panel / Panneau télescope	AC-TELE
8	1	Double Wall Slide 24" / Glissoire simple 24"	FS-2DWFS
9	1	Inclined Half Loop Climber 48" / Grimpeur à demi-boucles incliné 48"	FS-IHLO-CL-48
10	1	Shark Pod Climber 36" / Grimpeur Requin 36"	FS-SHRK-PD-36
11	1	Security Panel/Panneau de sécurité	Riser-24
12	3	Transfer support / Support de transfert	R10P
13	1	Ship Ladder 48"/Échelle de bateau 48"	FS-SHIP-LA-48
14	1	KG Weather Station / Panneau météo KG	KG-WTHR
15	1	KG Alphabet Panel (CUSTOM WRITTING)/ Panneau alphabet KG (PERSONNALISÉ)	KG-Alpha-C
16	1	Star Flague / Drapeau étoile	FLAGUE-ST

**Ktheme-105BtM2**

Min. Protective Surface Required / Surface de protection min. requise :  
 9.3 m (30'-7") x 8.6 m (28'-3")

Equipment Dimensions / Dimensions de l'équipement :  
 4.9 m (16'-3") x 5.7 m (18'-7")

Approval date: 13/04/2017

Rev: 00

Initial: AMR

CAN/CSA-Z614-xx  
 xx: Last Edition Published/  
 Dernière édition publiée

Recommended Ages / Âges recommandés :  
 18 months to 5 years old / 18 mois à 5 ans

Capacity / Peut accueillir :  
 up to 25 children / Jusqu'à 25 enfants





23 ch. Boom Lane, Unit/Unité E, Industrial Park/Parc industriel  
Atholville, New/Nouveau-Brunswick  
Canada, E3N 4E8

Tel/tél. : 1-888-212-1411 - Fax/télé. : 1-888-789-0987  
contact@kangoroo.com / www.kangoroo.com

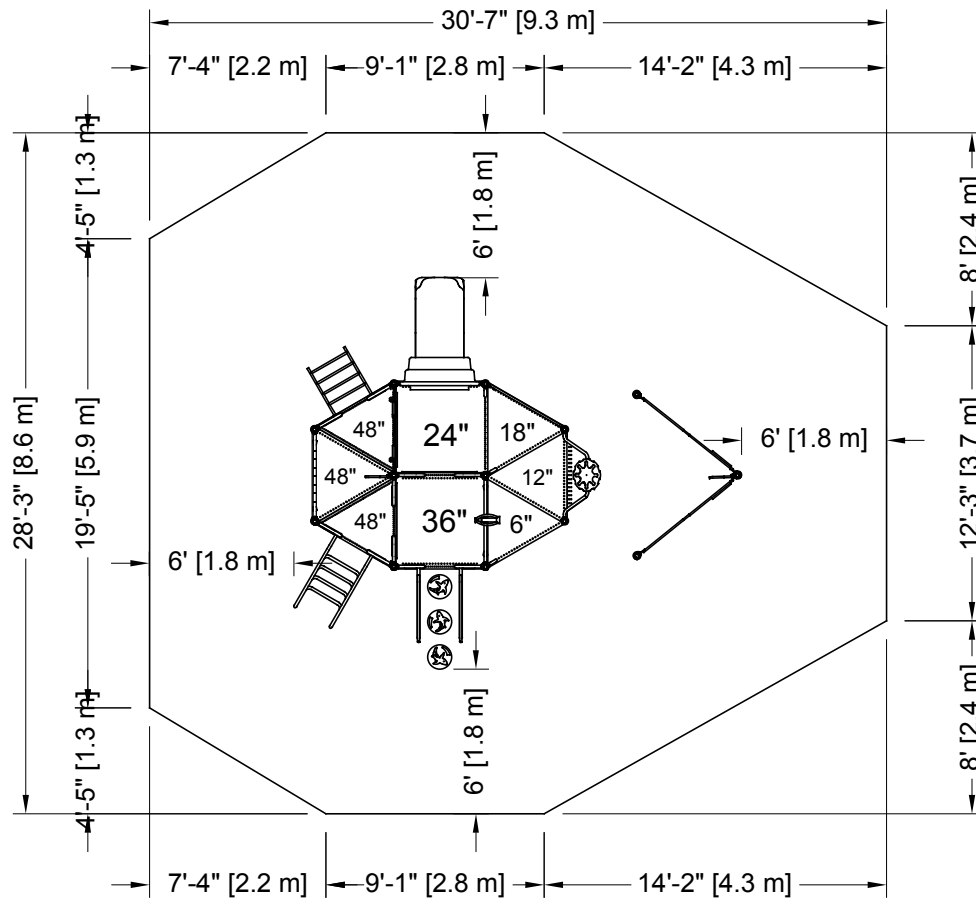

PLATFORM HEIGHTS  
HAUTEURS DE PLATEFORME

6" = 152MM	60" = 1524MM
12" = 305MM	72" = 1829MM
18" = 457MM	84" = 2134MM
24" = 609MM	96" = 2438MM
36" = 915MM	
48" = 1219MM	



**ZONE DE PROTECTION:**

Chaque équipement doit avoir une zone de protection constituée d'une surface sans obstacle qui se prolonge dans toutes les directions à partir du périmètre de l'équipement. Cette zone doit contenir un revêtement de surface (gravillon, sable, etc...) avec une capacité d'amortissement selon les normes CSA-Z614. Sauf avis contraire.

**Zone de protection minimum requise:**

9.3 m (30'-7")  
x  
8.6 m (28'-3")

- Aire : 66.58 m ca. (716.64 pi. ca.)
- Périmètre : 30.30 m (99'-5")

**PROTECTIVE SURFACING ZONE:**

Each equipment shall have a protective surfacing zone that consist of obstacle-free surfacing surrounding the equipment. This zone shall contain shock absorbing material (pea gravel, sand, etc...) that comply with CSA-Z614. Unless noted otherwise.

**Minimum Protective Surfacing Zone required:**

9.3 m (30'-7")  
x  
8.6 m (28'-3")

- Surface: 66.58 sq. m (716.64 sq. ft.)
- Perimeter: 30.30 m (99'-5")

**MÉTHODES D'INSTALLATION**

1

**DANS LE BÉTON:**

- Quantité de Sonotube de 12" Ø x 12' :3

Béton :  
- 0.99 m. cu.  
( 1.3 vge cu.)



2

**SYSTÈME AUTO-PORTANT:**

Qté charpentes: 5

Béton :  
- 0.31 m. cu.  
(0.4 vge cu.)



**INSTALLATION METHODES**

1

**CONCRETE:**

- Quantity of Sonotube of 12" Ø x 12':3

Concrete:  
- 0.99 cu. m.  
(1.3 cu. yd.)

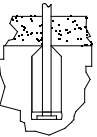

2

**FREE-STANDING SYSTEM:**

Frame QTY: 5

Concrete:  
- 0.31 cu. m.  
(0.4 cu. yd.)



**Attention :**  
**AIRE DE CIRCULATION LIBRE:**  
Aire dégagée d'obstacle qui se prolonge sur au moins 1.8m (70.87") au delà de la zone de protection. Voir dessin pour les détails.

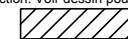

**Warning:**  
**NO-ENCROACHMENT ZONE :**  
Obstacle-free zone extending at least 1.8m (70.87") beyond the protective surfacing zone. See drawing for details.



**Kthème-105BtM2**

Equipment Dimensions / Dimensions de l'équipement :  
4.9 m (16'-3") x 5.7 m (18'-7")

Recommended Ages / Âges recommandés :  
18 months to 5 years old  
18 mois à 5 ans

CAN/CSA-Z614-xx  
xx: Last Edition Published /  
Dernière édition publiée

Capacity / Peut accueillir :  
up to 25 children / Jusqu'à 25 enfants

Fall Height /  
Hauteur de chute:  
2.29 m (7'-6")

Approval date: 13-04-2017  
Rev: 00  
Initial: AMR

