



23 ch. Boom Lane, Unit/Unité E
 Industrial Park/Parc industriel
 Atholville, New/Nouveau-Brunswick
 Canada, E3N 4E8
 Tel/tél. : 1-888-212-1411/Fax/télec. : 1-888-789-0987
 contact@kangaroo.com / www.kangaroo.com

Colors / Couleurs

Post / Poteaux: White & Red/Blanc et Rouge

Accent Color / Couleur complémentaire:
 Blue,Red,White

1 Color panel / Panneaux 1 couleur: Red/Rouge

2 colors panel / Panneaux 2 couleurs :
 Blue,Red,White
 Bleu,rouge,blanc,jaune

Slide / Glissoire: Red/Rouge

Plastic Climbers / Grimpeur Plastique:
 NA

Cable / Cable : NA

Roof / Toit : NA

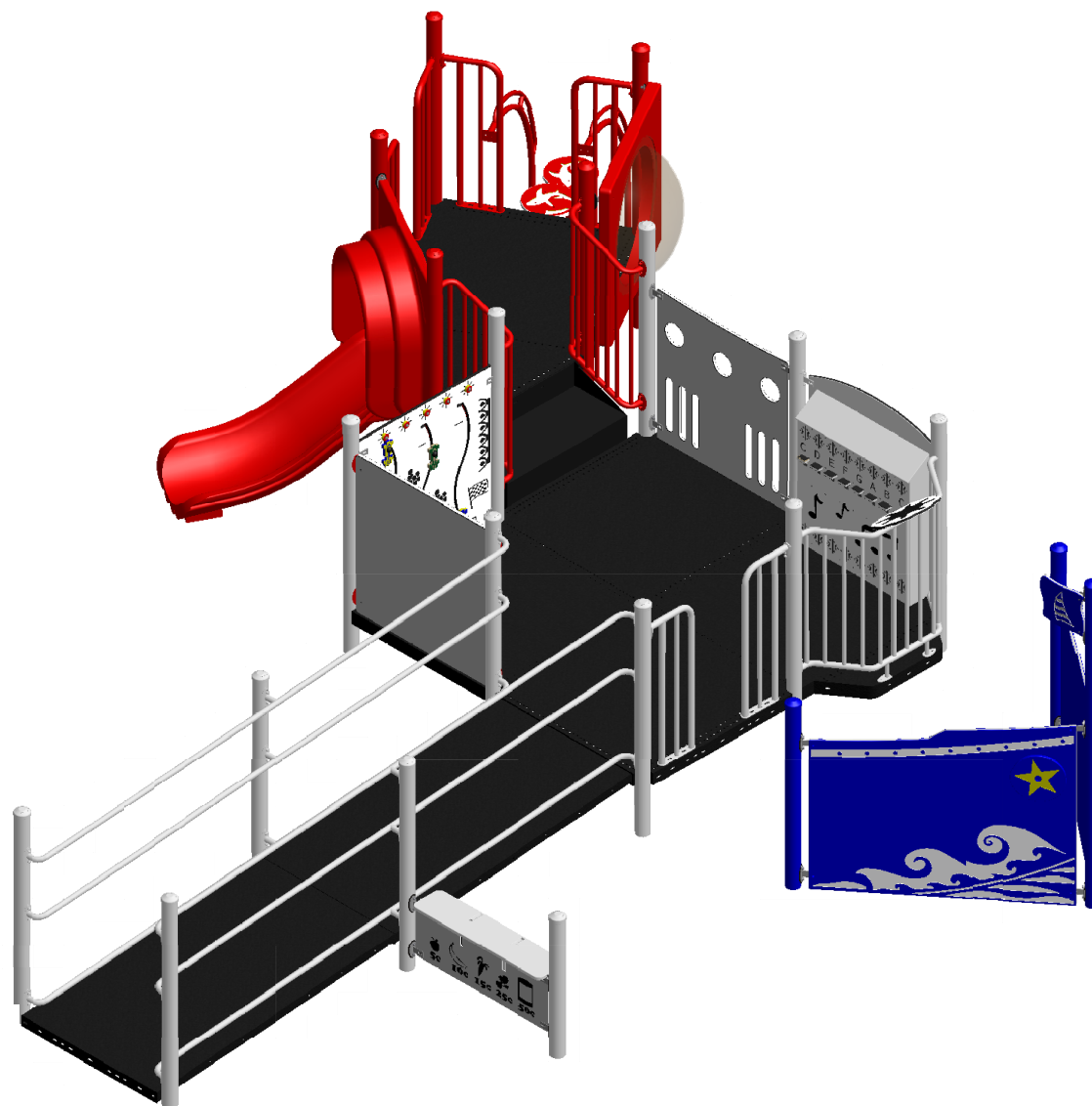

Ktheme-103BtM2

Min. Protective Surface Required / Surface de protection min. requise :
 9.5 m (31'-0") x 10.5 m (34'-6")

Equipment Dimensions / Dimensions de l'équipement :
 7.6 m (25'-0") x 6.8 m (22'-6")

Approval date: 19/11/2015

Rev: 00

Initial: TLG

CAN/CSA-Z614-xx
 xx: Last Edition Published/
 Dernière édition publiée

Recommended Ages / Âges recommandés :
 18 months to 5 years old / 18 mois à 5 ans

Capacity / Peut accueillir :
 up to 30 children / Jusqu'à 30 enfants





23 ch. Boom Lane, Unit/Unité E
 Industrial Park/Parc industriel
 Atholville, New/Novveau-Brunswick
 Canada, E3N 4E8
 Tel/tél. : 1-888-212-1411/Fax/télééc. : 1-888-789-0987
 www.kangaroo.com

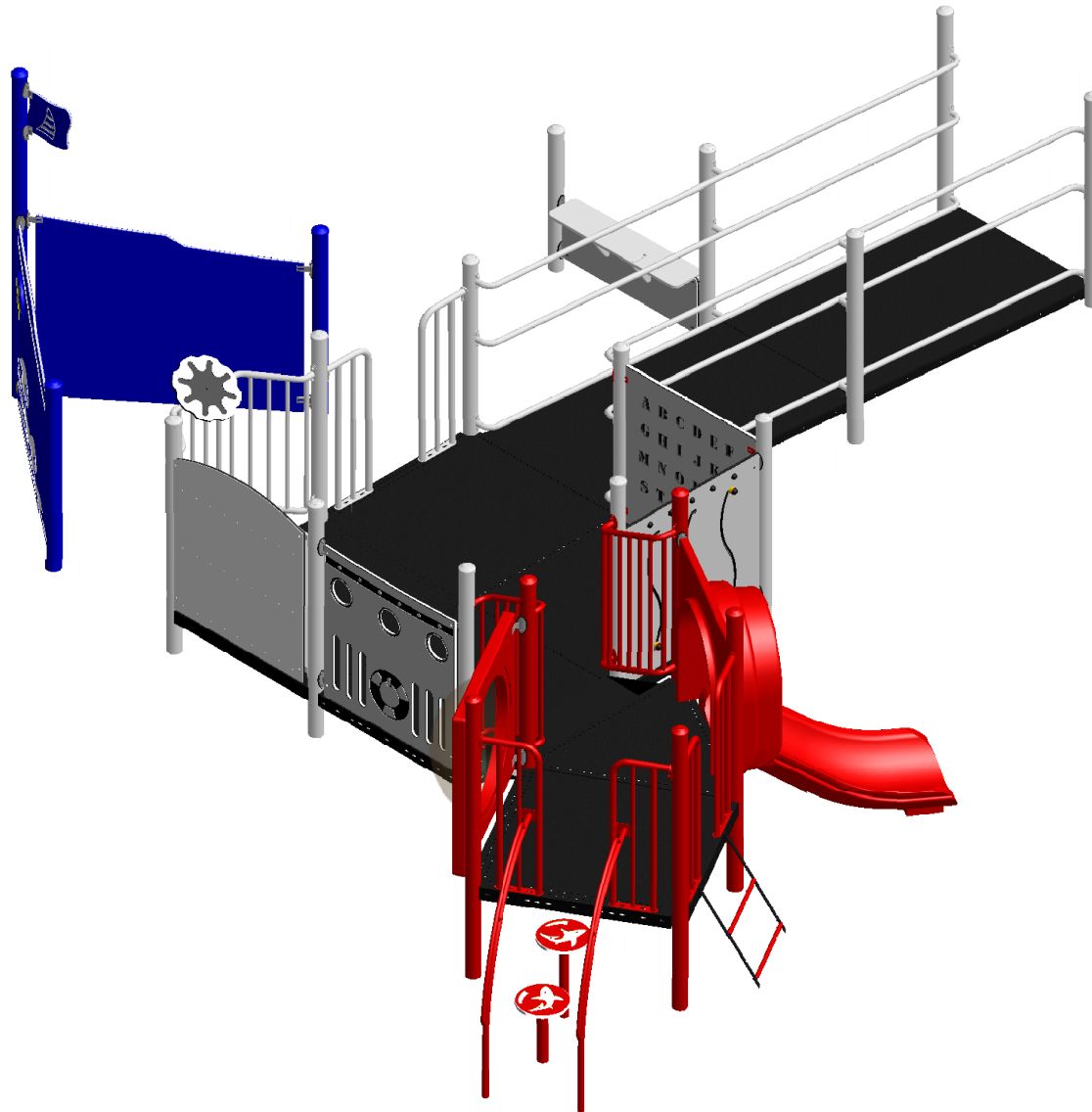

Ktheme-103BtM2	Min. Protective Surface Required / Surface de protection min. requise : 9.5 m (31'-0") x 10.5 m (34'-6")	Equipment Dimensions / Dimensions de l'équipement : 7.6 m (25'-0") x 6.8 m (22'-6")	Approval date: 19/11/2015 Rev: 00 Initial: TLG
CAN/CSA-Z614-xx xx: Last Edition Published/ Dernière édition publiée	Recommended Ages / Âges recommandés : 18 months to 5 years old / 18 mois à 5 ans	Capacity / Peut accueillir : up to 30 children / Jusqu'à 30 enfants	



23 ch. Boom Lane, Unit/Unité E
 Industrial Park/Parc industriel
 Atholville, New/Nouveau-Brunswick
 Canada, E3N 4E8
 Tel/tél. : 1-888-212-1411/Fax/télééc. : 1-888-789-0987
 www.kangoroo.com

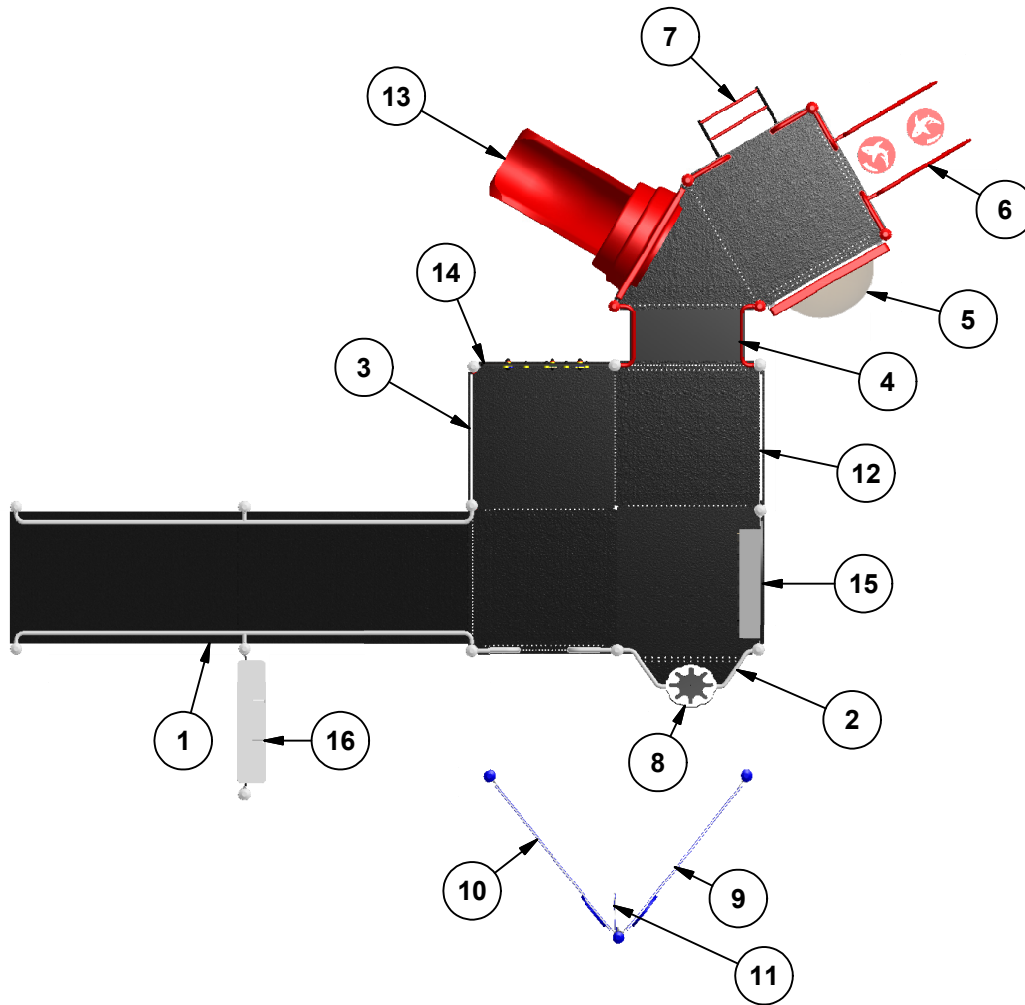

Legend / Légende

ITEM	QTY	Description	PART # / # PIECE
1	1	Acc. Ramp 1:12 / Rampe Acc. 1:12	DCK-RMP
2	1	Balcony Deck / Balcon	PF-BD
3	1	KG Alphabet Panel / Panneau alphabet KG	KG-Alpha
4	1	Transfer Stairs 12"/ Marches de transfer 12"	TRS-STAIR-12
5	1	Bubble Panel / Panneau Bulle	AC-BUB
6	1	Shark Pod Climber 24" / Grimpeur Requin 24"	FS-SHRK-PD-24
7	1	Ship Ladder 24" / Échelle de bateau 24"	SHP-24
8	1	Small Ship Wheel / Petit gouvernail	SHIP-WHEEL
9	1	KG Right Boat Bow/Coque de bateau droite KG	KG-RGHT-BT-BOW
10	1	KG Left Boat Bow/Coque de bateau gauche KG	KG-LFT-BT-BOW
11	1	Nautica Flag / Drapeau nautique	FLAGUE
12	1	KG Buoy Panel / Panneau bouée KG	KG-BUOY
13	1	Double Wall Slide 24" / Glissoire simple 24"	2DWFS
14	1	KG F1 Race Panel / Panneau de course F1 KG	KG-F1
15	1	KG Piano Panel / Piano KG	KG-Piano
16	1	KG Counter Panel/Panneau comptoir KG	KG-Counter

Ktheme-103BtM2

Min. Protective Surface Required / Surface de protection min. requise :
 9.5 m (31'-0") x 10.5 m (34'-6")

Equipment Dimensions / Dimensions de l'équipement :
 7.6 m (25'-0") x 6.8 m (22'-6")

Approval date: 19/11/2015
 Rev: 00
 Initial: TLG

CAN/CSA-Z614-xx
 xx: Last Edition Published/
 Dernière édition publiée

Recommended Ages / Âges recommandés :
 18 months to 5 years old / 18 mois à 5 ans

Capacity / Peut accueillir :
 up to 30 children / Jusqu'à 30 enfants





**Access to All /
Accessible**

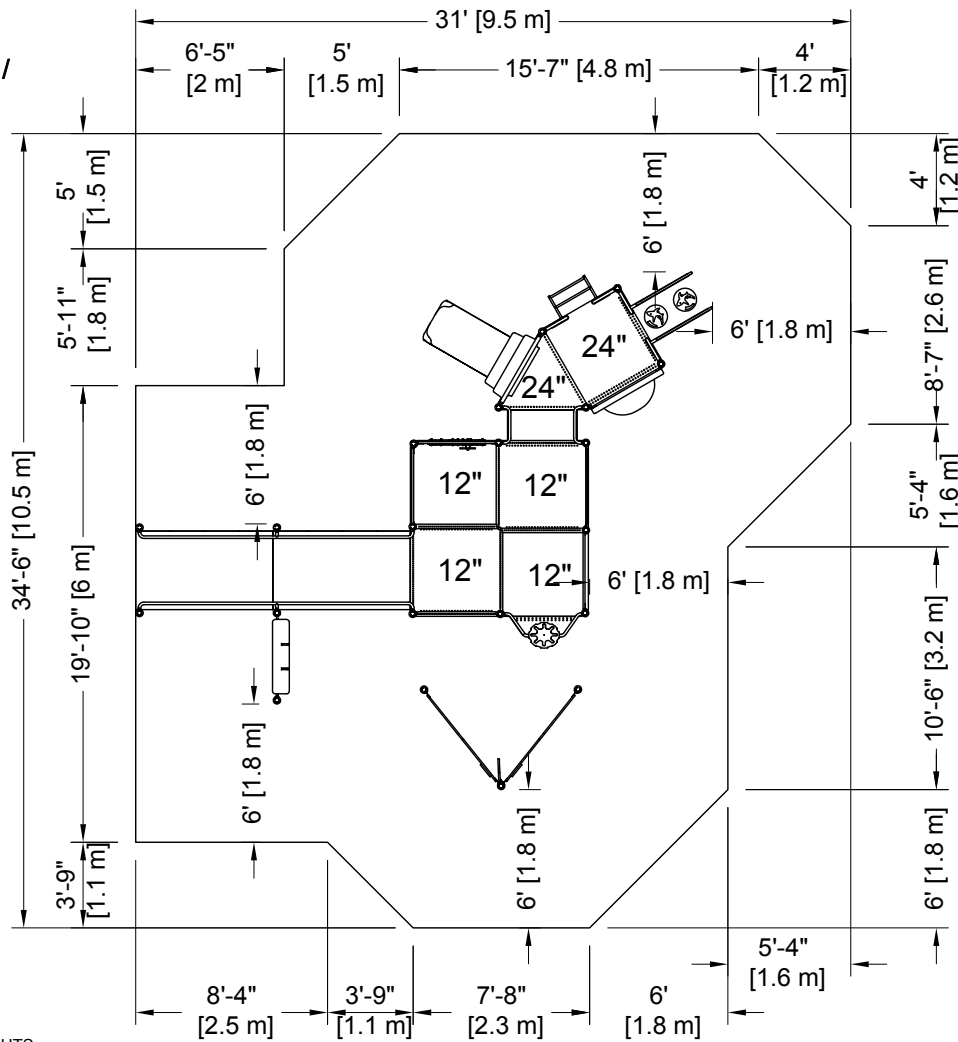

**PLATFORM HEIGHTS
HAUTEURS DE PLATEFORME**

12" = 305MM	60" = 1524MM
24" = 609MM	72" = 1829MM
36" = 915MM	84" = 2134MM
48" = 1219MM	96" = 2438MM



23 ch. Boom Lane, Unit/Unité E, Industrial Park/Parc industriel
Atholville, New/Nouveau-Brunswick
Canada, E3N 4E8
Tel/tél. : 1-888-212-1411 - Fax/télééc. : 1-888-789-0987
contact@kangoroo.com / www.kangoroo.com

ZONE DE PROTECTION:

Chaque équipement doit avoir une zone de protection constituée d'une surface sans obstacle qui se prolonge dans toutes les directions à partir du périmètre de l'équipement. Cette zone doit contenir un revêtement de surface (gravillon, sable, etc...) avec une capacité d'amortissement selon les normes CSA-Z614. Sauf avis contraire.

Zone de protection minimum requise:

9.5 m (31'-0")
x
10.5 m (34'-6")

- Aire : 76.22 m ca.
(820.48 pi. ca.)
- Périmètre : 35.67 m
(117'-0")

PROTECTIVE SURFACING ZONE :

Each equipment shall have a protective surfacing zone that consist of obstacle-free surfacing surrounding the equipment. This zone shall contain shock absorbing material (pea gravel, sand, etc...) that comply with CSA-Z614. Unless noted otherwise.

Minimum

Protective Surfacing Zone required:

9.5 m (31'-0")
x
10.5 m (34'-6")

- Surface: 76.22 sq. m
(820.48 sq. ft.)
- Perimeter: 35.67 m
(117'-0")

MÉTHODES D'INSTALLATION

1

DANS LE BÉTON:

- Quantité de Sonotube de 12" Ø x 12" : 4

Béton :
- 1.59 m. cu.
(2.1 vge cu.)



1

CONCRETE:

- Quantity of Sonotube of 12" Ø x 12": 4

Concrete:
- 1.59 cu. m.
(2.1 cu. yd.)

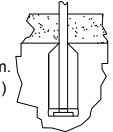

2

SYSTÈME AUTO-PORTANT:

Qté charpentes: 12
Béton :
- .31 m. cu.
(0.4 vge cu.)



2

FREE-STANDING SYSTEM

Frame QTY: 12
Concrete:
- .31 cu. m.
(0.4 cu. yd.)

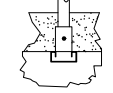

Attention :

AIRE DE CIRCULATION LIBRE:

Aire dégagée d'obstacle qui se prolonge sur au moins 1.8m (70.87") au delà de la zone de protection. Voir dessin pour les détails.

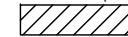

Warning:

NO-ENCROACHMENT ZONE

Obstacle-free zone extending at least 1.8m (70.87") beyond the protective surfacing zone. See drawing for details.



Ktheme-103BtM2

Equipment Dimensions / Dimensions de l'équipement :
7.6 m (25'-0") x 6.8 m (22'-6")

Recommended Ages / Âges recommandés :

18 months to 5 years old
18 mois à 5 ans

CAN/CSA-Z614-xx
xx: Last Edition Published /
Dernière édition publiée

Capacity / Peut accueillir :
up to 30 children / Jusqu'à 30 enfants

Fall Height /
Hauteur de chute:
1.68 m (5'-6")

Approval date: 20-11-2015

Rev: 00
Initial: TLG

