

23 ch. Boom Lane, Unit/Unité E Industrial
 Park/Parc industriel Atholville, New/Nouveau-
 Brunswick Canada, E3N 4E8
 Tel/tél. : 1-888-212-1411/Fax/télééc. : 1-888-
 789-0987 www.kangaroo.com

Kroll-196

Min. Protective Surface Required / Surface de protection min. requise
 9.75 m (32') x 10.93.m (35'-10")

Equipment Dimensions / Dimensions de l'équipement :
 6 m (20') x 7.3m (23'-10")

Approval date: 2023-05-29

Rev: 01

CAN/CSA-Z614

Recommended Ages / Âges recommandés :
 5 years to 12 years old / 5 ans à 12 ans

Capacity / Peut accueillir : up to children / Jusqu'à enfants

Initial: O.P.



23 ch. Boom Lane, Unit/Unité E Industrial
 Park/Parc industriel Atholville, New/Nouveau-
 Brunswick Canada, E3N 4E8
 Tel/tél. : 1-888-212-1411/Fax/télec. : 1-888-
 789-0987 www.kangoroo.com

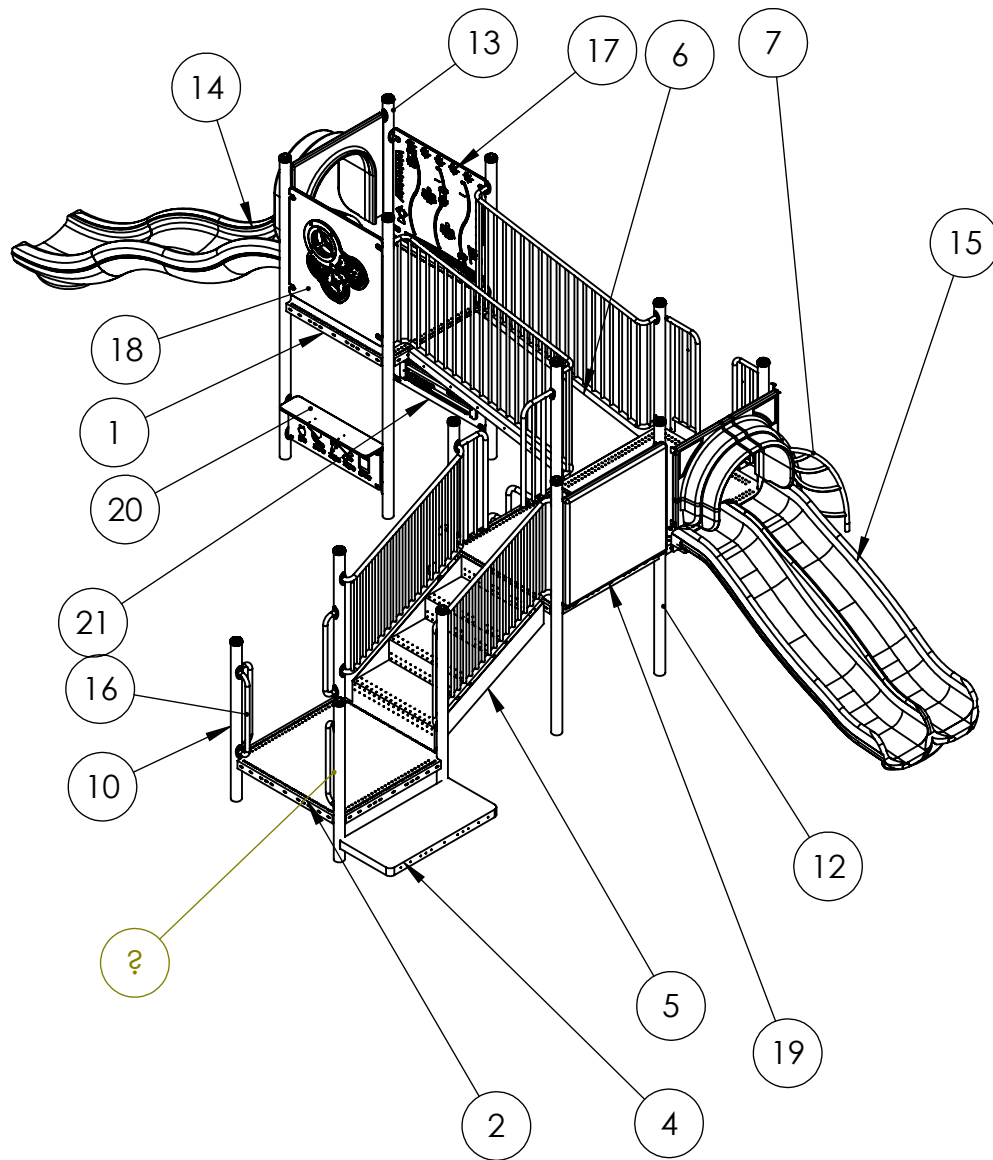

ITEM NO.	DESCRIPTION	QTY.
1	Platform 48"	2
2	Platform 48"	1
3	Platform 48"	1
4	Platform 48"x24"	1
5	Stairs 12" to 48"	1
6	Inclined bridge 12"	1
7	Climber loop arch 48"	1
8	Pommel climber 48"	1
9	Post 4' ft	1
10	Post 5' ft	1
11	Post 6' ft	2
12	Post 8' ft	6
13	Post 9.5' ft	4
14	Slide wavy double 48"	1
15	Slide triple rail	1
16	Handrail	4
17	Panel rally F1	1
18	Panel gear	1
19	Panel SPI Sign language	1
20	Panel counter	1
21	Panel Abacus small	1

Kroll-196

Min. Protective Surface Required / Surface de protection min. requise
 9.75 m (32') x 10.93.m (35'-10")

Equipment Dimensions / Dimensions de l'équipement :
 6 m (20') x 7.3m (23'-10")

Approval date: 2023-05-29

Rev: 01

CAN/CSA-Z614

Recommended Ages / Âges recommandés :
 5 years to 12 years old / 5 ans à 12 ans

Capacity / Peut accueillir : up to children / Jusqu'à enfants

Initial: O.P.



23 ch. Boom Lane, Unit/Unité E Industrial Park/Parc industriel
 Atholville, New/Nouveau-Brunswick Canada, E3N 4E8
 Tel/tél. : 1-888-212-1411/Fax/télééc. : 1-888-789-0987
 www.kangoroo.com

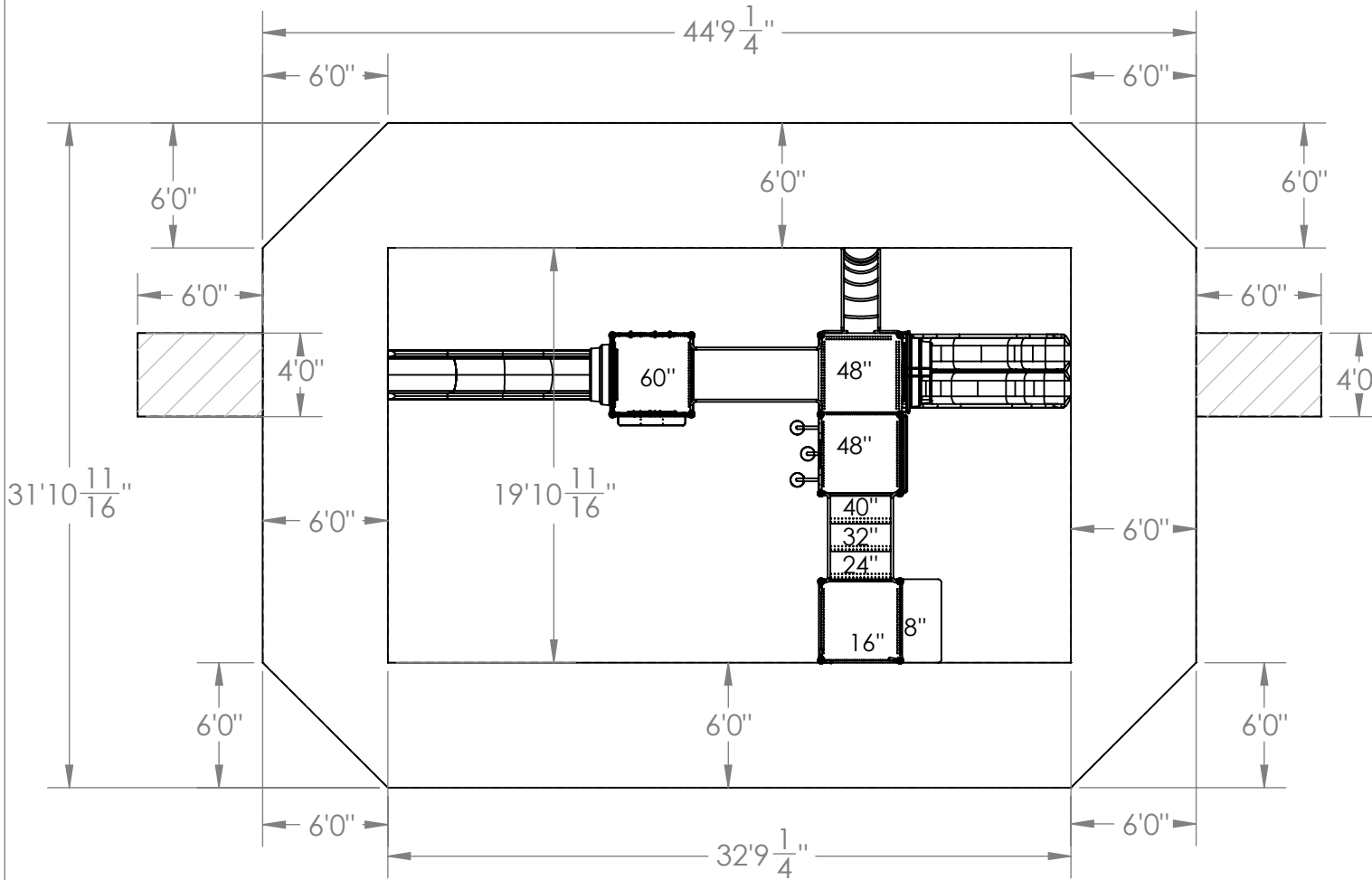

PLATFORM HEIGHTS
 HAUTEURS DE PLATEFORME

12" = 305MM	24" = 609MM
36" = 915MM	48" = 1219MM
60" = 1524MM	72" = 1829MM
84" = 2134MM	96" = 2438MM

<p>ZONE DE PROTECTION:</p> <p>Chaque équipement doit avoir une zone de protection constituée d'une surface sans obstacle qui se prolonge dans toutes les directions à partir du périmètre de l'équipement. Cette zone doit contenir un revêtement de surface (gravillon, sable, etc...) avec une capacité d'amortissement selon les normes CSA-Z614. Sauf avis contraire.</p> <p>Zone de protection minimum requise:</p> <ul style="list-style-type: none"> 10.07m (31'10 11/16") x 13.64 m (44'9 1/4") - Surface: 128.6 sq. m (1384'24" sq. ft.) - Perimeter: 43m (141' ft) 	<p>PROTECTIVE SURFACING ZONE :</p> <p>Each equipment shall have a protective surfacing zone that consist of obstacle-free surfacing surrounding the equipment. This zone shall contain shock absorbing material (pea gravel, sand, etc...) that comply with CSA-Z614. Unless noted otherwise.</p> <p>Minimum Protective Surfacing Zone required:</p> <ul style="list-style-type: none"> 10.07m (31'10 11/16") x 13.64 m (44'9 1/4") - Surface: 128.6 sq. m (1384'24" sq. ft.) - Perimeter: 43m (141' ft)
-----------------------------------------------------------------------------------------------------------------------------------------------------------------------------------------------------------------------------------------------------------------------------------------------------------------------------------------------------------------------------------------------------------------------------------------------------------------------------------------------------------------------------------------------------------------------------------------------------------------------------	--------------------------------------------------------------------------------------------------------------------------------------------------------------------------------------------------------------------------------------------------------------------------------------------------------------------------------------------------------------------------------------------------------------------------------------------------------------------------------------------------------------------------------------------------

<p>MÉTHODES D'INSTALLATION</p> <p>①</p> <p>DANS LE BÉTON:</p> <ul style="list-style-type: none"> - Quantité de Sonotube de 12" Ø x 12' :6 <p>Béton: -3.0m.cu. (3.3vge.cu.)</p>	<p>INSTALLATION METHODS</p> <p>①</p> <p>CONCRETE</p> <ul style="list-style-type: none"> -Quantity of sonotube of 12"Øx12':6 <p>CONCRETE -3.0 cu.m. (3.3cu.yd.)</p>
----------------------------------------------------------------------------------------------------------------------------------------------------------------------------------------------------------------	----------------------------------------------------------------------------------------------------------------------------------------------------------------------------------------------------

<p>②</p> <p>SYSTÈME AUTO-PORTANT:</p> <p>Qté charpentes: NA</p> <p>Béton: - 0 m. cu. (0vge cu.)</p>	<p>②</p> <p>FREE-STANDING SYSTEM:</p> <p>Frame QTY: NA</p> <p>Concrete: - 0 cu. m. -(0 cu. yd.)</p>
-----------------------------------------------------------------------------------------------------------------------------	-----------------------------------------------------------------------------------------------------------------------------

<p>Attention :</p> <p>AIRE DE CIRCULATION LIBRE:</p> <p>Aire dégagée d'obstacle qui se prolonge sur au moins 1.8m (70.87") au delà de la zone de protection. Voir dessin pour les détails.</p>	<p>Warning:</p> <p>NO-ENCROACHMENT ZONE :</p> <p>Obstacle-free zone extending at least 1.8m (70.87") beyond the protective surfacing zone. See drawing for details.</p>
--------------------------------------------------------------------------------------------------------------------------------------------------------------------------------------------------------------	---------------------------------------------------------------------------------------------------------------------------------------------------------------------------------------

Kroll-196	Min. Protective Surface Required / Surface de protection min. requise 10.07m (31'10 11/16") x 13.64 m (44'9 1/4")	Equipment Dimensions / Dimensions de l'équipement :6.06m(19'11")x10.07m(32'9")	Fall Height / Hauteur de chute: 2.64 m (8'8")	Approval date: 2023-05-29 Rev: 01 Initial: OP
CAN/CSA-Z614	Recommended Ages / Âges recommandés : 5 years to 12 years old / Sans à 12 ans	Capacity / Peut accueillir : up to 30 children / Jusqu'à 30 enfants		