



23 ch. Boom Lane, Unit/Unité E Industrial
 Park/Parc industriel Atholville, New/Nouveau-
 Brunswick Canada, E3N 4E8
 Tel/tél. : 1-888-212-1411/Fax/télé. : 1-888-
 789-0987 www.kangaroo.com



Kroll-195

Min. Protective Surface Required / Surface de protection min. requise
 13.7 m (44'-10.7") x 9.7m (31'-11")

Equipment Dimensions / Dimensions de l'équipement :
 10m (32'-10.7") x 5.7m (18'-8.3")

Approval date: 2023-01-19

Rev: 00

CAN/CSA-Z614

Recommended Ages / Âges recommandés :
 5 Years to 12 Years old / 5 Ans à 12 Ans

Capacity / Peut accueillir : up to 30 children / Jusqu'à 30 enfants

Initial: S.T



23 ch. Boom Lane, Unit/Unité E Industrial
Park/Parc industriel Atholville, New/Nouveau-
Brunswick Canada, E3N 4E8
Tel/tél. : 1-888-212-1411/Fax/télé. : 1-888-
789-0987 www.kangaroo.com



Kroll-195

Min. Protective Surface Required / Surface de protection min. requise
13.7 m (44'-10.7") x 9.7m (31'-11")

Equipment Dimensions / Dimensions de l'équipement :
10m (32'-10.7") x 5.7m (18'-8.3")

Approval date: 2023-01-19

Rev: 00

CAN/CSA-Z614



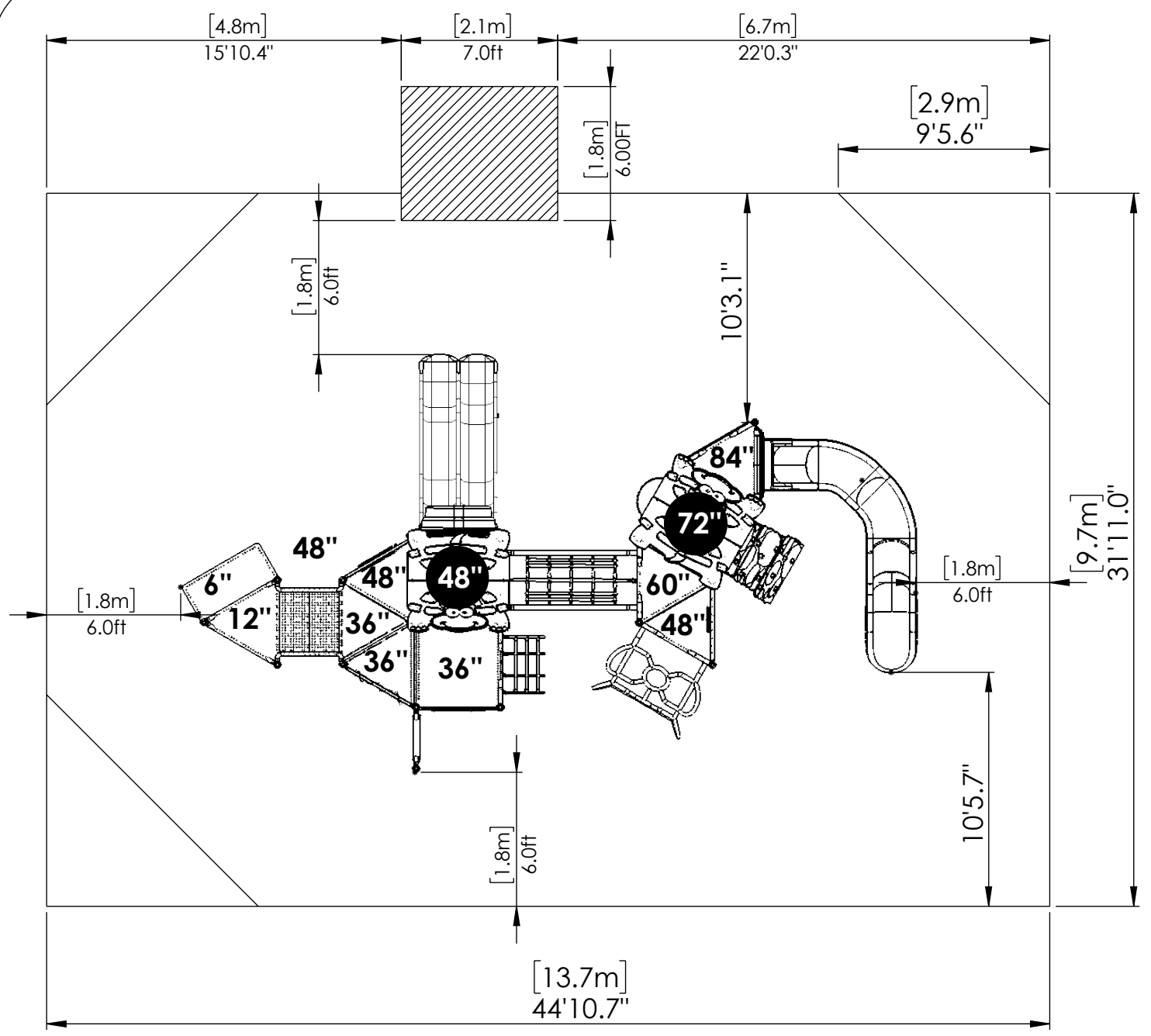

Recommended Ages / Âges recommandés :
5 Years to 12 Years old / 5 Ans à 12 Ans

Capacity / Peut accueillir : up to 30 children / Jusqu'à 30 enfants

Initial: S.T

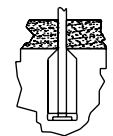
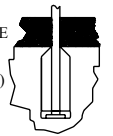

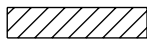
23 ch. Boom Lane, Unit/Unité E Industrial Park/Parc industriel
 Atholville, New/Nouveau-Brunswick Canada, E3N 4E8
 Tel/tél. : 1-888-212-1411/Fax/télé. : 1-888-789-0987
 www.kangoroo.com

<p>ZONE DE PROTECTION: Chaque équipement doit avoir une zone de protection constituée d'une surface sans obstacle qui se prolonge dans toutes les directions à partir du périmètre de l'équipement. Cette zone doit contenir un revêtement de surface (gravillon, sable, etc...) avec une capacité d'amortissement selon les normes CSA-Z614. Sauf avis contraire. Zone de protection minimum requise: 13.7 m (44'-10.7") x 9.7 m (31'-11") - Surface: 132.89 sq. m (1430.4 sq. ft.) - Perimeter: 46.8 m (153'-6")</p>	<p>PROTECTIVE SURFACING ZONE : Each equipment shall have a protective surfacing zone that consist of obstacle-free surfacing surrounding the equipment. This zone shall contain shock absorbing material (pea gravel, sand, etc...) that comply with CSA-Z614. Unless noted otherwise. Minimum Protective Surfacing Zone required: 13.7 m (44'-10.7") x 9.7 m (31'-11") - Surface: 132.89 sq. m (1430.4 sq. ft.) - Perimeter: 46.8 m (153'-6")</p>
<p>MÉTHODES D'INSTALLATION 1 DANS LE BÉTON: - Quantité de Sonotube de 12" x 12" : 20 Béton: - 2.1m.cu. (2.75vge.cu.)</p> 	<p>INSTALLATION METHODS 1 CONCRETE -Quantity of sonotube of 12"Øx12":20 CONCRETE -2.1 cu.m. (2.75cu.yd.)</p> 
<p>2 SYSTÈME AUTO-PORTANT: Qté charpentes: 11 Béton : - 0.0 m. cu. (0.0 vge cu.)</p> 	<p>2 FREE-STANDING SYSTEM: Frame QTY: 11 Concrete: - 0.0 cu. m. (-0.0 cu. yd.)</p> 
<p>Attention : AIRE DE CIRCULATION LIBRE: Aire dégagée d'obstacle qui se prolonge sur au moins 1.8m (70.87") au delà de la zone de protection. Voir dessin pour les détails.</p> 	<p>Warning: NO-ENCROACHMENT ZONE : Obstacle-free zone extending at least 1.8m (70.87") beyond the protective surfacing zone. See drawing for details.</p> 

Kroll-195
 CAN/CSA-Z614

Equipment Dimensions / Dimensions de l'équipement :
 10m (32'-10.7") x 5.7m (18'-8.3")
 Capacity / Peut accueillir : up to
 30 children / Jusqu'à 30 enfants

Fall Height /
 Hauteur de chute:
 1.8 m (5'-1")

Approval date: 19-01-23
 Rev: 00
 Initial: IN

23 ch. Boom Lane, Unit/Unité E Industrial
 Park/Parc industriel Atholville, New/Nouveau-
 Brunswick Canada, E3N 4E8
 Tel/tél. : 1-888-212-1411/Fax/télé. : 1-888-
 789-0987 www.kangaroo.com

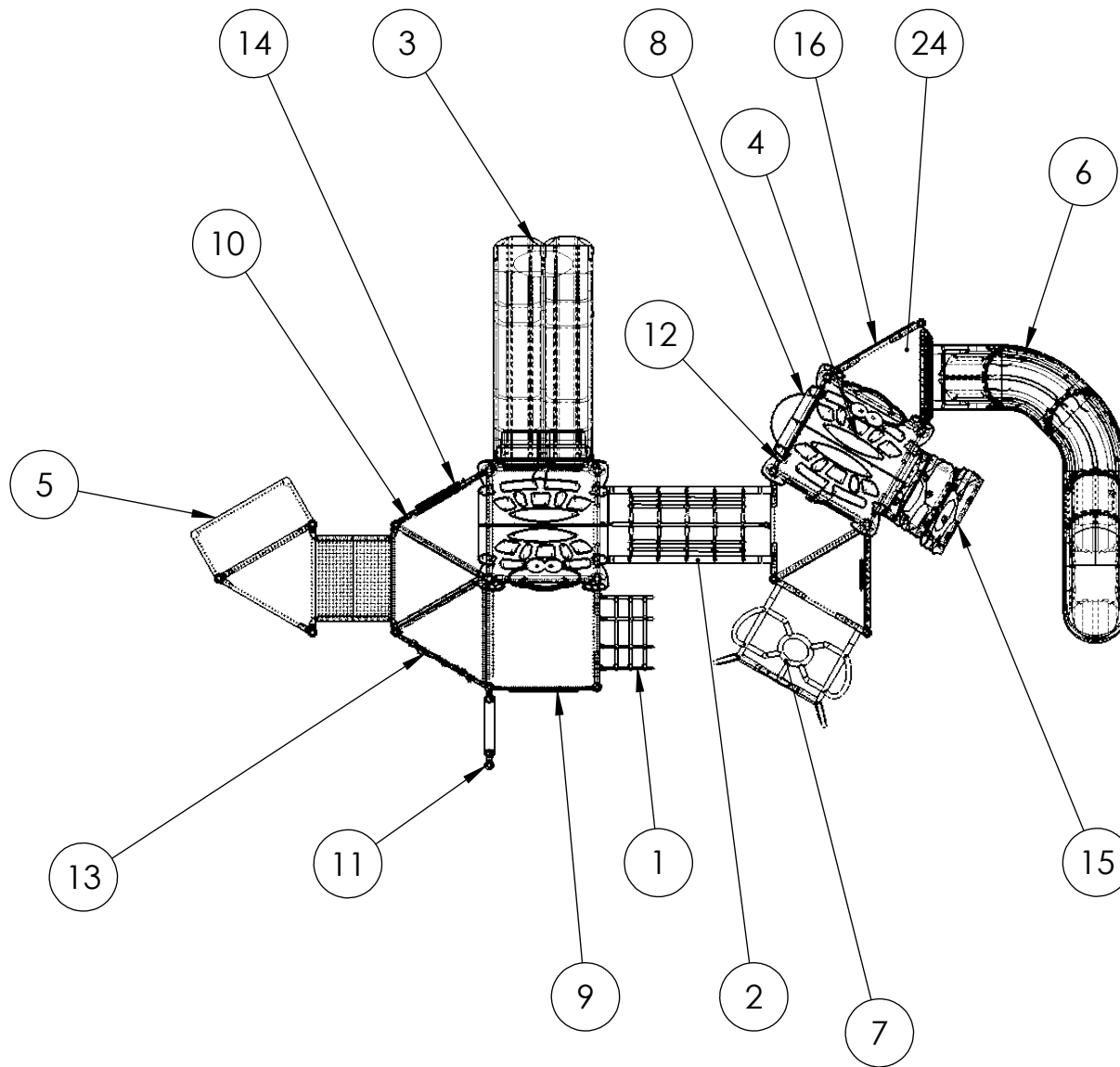

ITEM NO.	PART#	Description	QTY
1	Cable-climber-TRPL-36	CL-TRP-CH-36"	1
2	cable BRIDGE INCLINER_00	BRI-INCL	1
3	TRIPLE RAIL SLIDE 48	SLD-2-003-48"	1
4	Turtle-HDPE-Roof	Kg-HDPE2 color-roof-logo	2
5	Trans-Station-tri-FR36_00	Transfer Station Full Rail-36"	1
6	SGS-right-turn-84_00	Starglide Right Turn-84"	1
7	BOWTIE-CLIMBER-48_00	Climber 48"	1
8	Kg-Coffee-Shop	COFFEE SHOP PANEL	1
9	KG-TTT	Tic-Tak-Toe PANEL	1
10	KG-Xylophone_00	XYLOPHONE	1
11	Belt Rocker	belt swing	1
12	KG-CLOCK	Clock panel HDPE	1
13	KG-MEMORY-NATURE_01.0002	KG-Memory Pannel	1
14	KG-ABACUS-W-POST_00	ABACUS	1
15	FS-RCK-CH-72	Rock Challenge Climber 72" / Cap de roche 72"	1
16	ICE-CLIMBER-84	HDPE Climber	1

Kroll-195

Min. Protective Surface Required / Surface de protection min. requise
 13.7 m (44'-10.7") x 9.7m (31'-11")

Equipment Dimensions / Dimensions de l'équipement :
 10m (32'-10.7") x 5.7m (18'-8.3")

Approval date: 2023-01-19

Rev: 00

CAN/CSA-Z614

Recommended Ages / Âges recommandés :
 5 Years to 12 Years old / 5 Ans à 12 Ans

Capacity / Peut accueillir : up to 30 children / Jusqu'à 30 enfants

Initial: S.T