



23 ch. Boom Lane, Unit/Unité E, Industrial Park/Parc industriel
 Atholville, New-Brunswick, Canada, E3N 4E8
 Tel/tél. : 1-888-212-1411, Fax. : 1-888-789-0987
 contact@kangoroo.com / www.kangoroo.com



Colors / Couleurs

Post / Poteaux: Red / rouge

Accent Color / Couleur complémentaire:
 Yellow / jaune

1 Color panel / Panneaux 1 couleur: Red / rouge

2 colors panel / Panneaux 2 couleurs :
 Blue, White / bleu, blanc

Slide / Glissoire: Yellow, Cyan / jaune, cyan

Plastic Climbers / Grimpeur Plastique:
 Blue, White, Red / bleu, blanc, rouge

Cable / Cable : Blue / bleu

Roof / Toît : N/A

Kroll-186

Min. Protective Surface Required / Surface de protection min. requise :
 12.0 m (39'-4") x 9.7 m (31'-11")

Equipment Dimensions / Dimensions de l'équipement :
 8.3 m (27'-4") x 6.1 m (19'-11")

Approval date: 20/04/2018

Rev: 00

Initial: AMR

CAN/CSA-Z614-xx
 xx: Last Edition Published/
 Dernière édition publiée

Recommended Ages / Âges recommandés :
 18 months to 12 years old / 18 mois à 12 ans

Capacity / Peut accueillir :
 up to 35 children / Jusqu'à 35 enfants





23 ch. Boom Lane, Unit/Unité E
 Industrial Park/Parc industriel
 Atholville, New/Nouveau-Brunswick
 Canada, E3N 4E8
 Tel/tél. : 1-888-212-1411/Fax/télééc. : 1-888-789-0987
 www.kangoroo.com

| | | | |
|--|--|---|---|
| Kroll-186 | Min. Protective Surface Required / Surface de protection min. requise : 12.0 m (39'-4") x 9.7 m (31'-11") | Equipment Dimensions / Dimensions de l'équipement : 8.3 m (27'-4") x 6.1 m (19'-11") | Approval date: 20/04/2018 Rev: 00 Initial: AMR |
| CAN/CSA-Z614-xx xx: Last Edition Published/ Dernière édition publiée | Recommended Ages / Âges recommandés : 18 months to 12 years old / 18 mois à 12 ans | Capacity / Peut accueillir : up to 35 children / Jusqu'à 35 enfants |  |



23 ch. Boom Lane, Unit/Unité E
 Industrial Park/Parc industriel
 Atholville, New/Nouveau-Brunswick
 Canada, E3N 4E8
 Tel/tél. : 1-888-212-1411/Fax/télééc. : 1-888-789-0987
 www.kangaroo.com

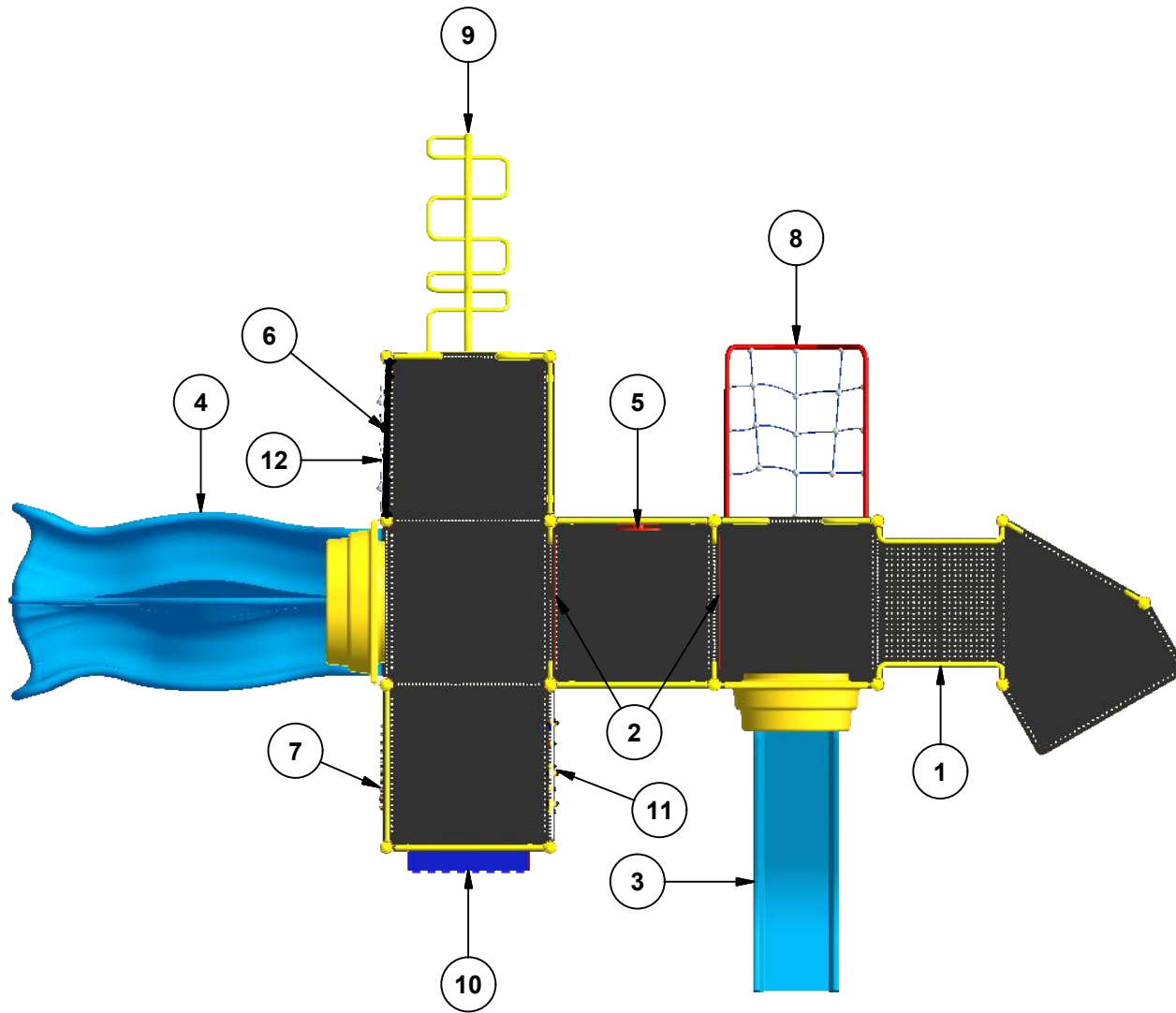

Legend / Légende

| ITEM | QTY | Description | PART # / # PIECE |
|------|-----|---|---------------------|
| 1 | 1 | Transfer Station 36"/Marches accessibles 36" | TRANST-36M1 |
| 2 | 2 | Riser 12"/contre-marche 12" | Riser-12 |
| 3 | 1 | Double Wall Slide 36"/Glissoire simple 36" | FS-3DWFS |
| 4 | 1 | Duo-Slide 60"/Glissoire double "Duo-Slide" 60" | FS-5TRS |
| 5 | 1 | Car Panel / Panneau auto | AC-CAR |
| 6 | 1 | KG Acc. Gear Panel / Panneau engrenage KG Acc. | KG-Agear |
| 7 | 1 | KG Acc. Abacus / Boulier Acc. KG | KG-Aabac |
| 8 | 1 | Funnel Climbing Net - 36" | FUNNEL-CLIMBING-NET |
| 9 | 1 | Inclined "S" Snake ladder 60"/Echelle serpentine inclinée 60" | INC-S-SNK-LA-60 |
| 10 | 1 | KG Piano Panel / Piano KG | KG-Piano |
| 11 | 1 | KG F1 Race Panel / Panneau de course F1 KG | KG-F1 |
| 12 | 1 | KG Memory Game / Jeux de mémoire KG | KG-MEMORY |

Kroll-186

Min. Protective Surface Required / Surface de protection min. requise :
 12.0 m (39'-4") x 9.7 m (31'-11")

Equipment Dimensions / Dimensions de l'équipement :
 8.3 m (27'-4") x 6.1 m (19'-11")

Approval date: 20/04/2018
 Rev: 00

CAN/CSA-Z614-xx
 xx: Last Edition Published/
 Dernière édition publiée

Recommended Ages / Âges recommandés :
 18 months to 12 years old / 18 mois à 12 ans

Capacity / Peut accueillir :
 up to 35 children / Jusqu'à 35 enfants

Initial: AMR





Access to All /
Accessible

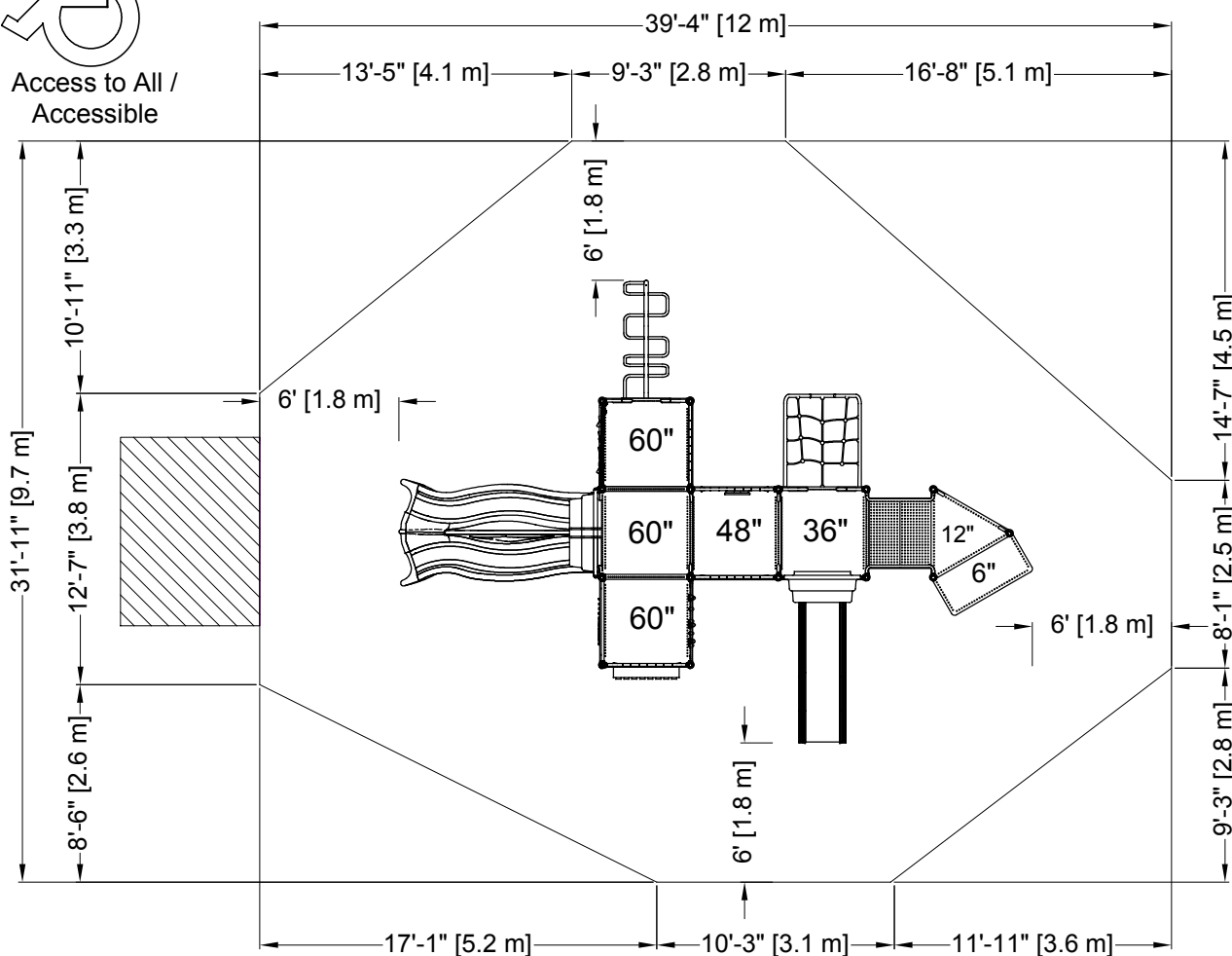

PLATFORM HEIGHTS
HAUTEURS DE PLATEFORME

| | |
|--------------|--------------|
| 10" = 254MM | 60" = 1524MM |
| 12" = 305MM | 72" = 1829MM |
| 24" = 609MM | 84" = 2134MM |
| 36" = 915MM | 96" = 2438MM |
| 48" = 1219MM | |



23 ch. Boom Lane, Unit/Unité E, Industrial Park/Parc industriel
Atholville, New/Nouveau-Brunswick
Canada, E3N 4E8
Tel/tél. : 1-888-212-1411 - Fax/télec. : 1-888-789-0987
contact@kangoroo.com / www.kangoroo.com

ZONE DE PROTECTION:

Chaque équipement doit avoir une zone de protection constituée d'une surface sans obstacle qui se prolonge dans toutes les directions à partir du périmètre de l'équipement. Cette zone doit contenir un revêtement de surface (gravillon, sable, etc...) avec une capacité d'amortissement selon les normes CSA-Z614. Sauf avis contraire.

Zone de protection minimum requise:

12.0 m (39'-4")
x
9.7 m (31'-11")

- Aire : 86.61 m ca.
(932.37 pi. ca.)
- Périmètre : 34.70 m
(113'-10")

PROTECTIVE SURFACING ZONE :

Each equipment shall have a protective surfacing zone that consist of obstacle-free surfacing surrounding the equipment. This zone shall contain shock absorbing material (pea gravel, sand, etc...) that comply with CSA-Z614. Unless noted otherwise.

Minimum
Protective Surfacing Zone required:

12.0 m (39'-4")
x
9.7 m (31'-11")

- Surface: 86.61 sq. m
(932.37 sq. ft.)
- Perimeter: 34.70 m
(113'-10")

MÉTHODES D'INSTALLATION

1

DANS LE BÉTON:

- Quantité de Sonotube de 12" Ø x 12" : 3

Béton :
- 1.29 m. cu.
(1.7 vge cu.)

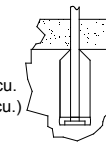

INSTALLATION METHODS

1

CONCRETE:

- Quantity of Sonotube of 12" Ø x 12": 3

Concrete:
- 1.29 cu. m.
(1.7 cu. yd.)

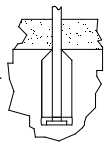

2

SYSTÈME AUTO-PORTANT:

Qté charpentes: 9

Béton :
- 0.00 m. cu.
(0.0 vge cu.)

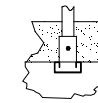

2

FREE-STANDING SYSTEM:

Frame QTY: 9

Concrete:
- 0.00 cu. m.
(0.0 cu. yd.)



Attention :

AIRE DE CIRCULATION LIBRE:

Aire dégagée d'obstacle qui se prolonge sur au moins 1.8m (70.87") au delà de la zone de protection. Voir dessin pour les détails.

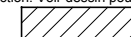

Warning:

NO-ENCROACHMENT ZONE :

Obstacle-free zone extending at least 1.8m (70.87") beyond the protective surfacing zone. See drawing for details.

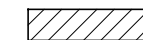

Kroll-186

Equipment Dimensions / Dimensions de l'équipement :
8.3 m (27'-4") x 6.1 m (19'-11")

Recommended Ages / Âges recommandés :
18 months to 12 years old
18 mois à 12 ans

CAN/CSA-Z614-xx
xx: Last Edition Published /
Dernière édition publiée

Capacity / Peut accueillir :
up to 35 children / Jusqu'à 35 enfants

Fall Height /
Hauteur de chute:
2.59 m (8'-6")

Approval date: 20-04-2018
Rev: 00
Initial: AMR

