



23 ch. Boom Lane, Unit/Unité E, Industrial Park/Parc industriel  
 Atholville, New-Brunswick, Canada, E3N 4E8  
 Tel/tél. : 1-888-212-1411, Fax. : 1-888-789-0987  
 contact@kangoroo.com / www.kangoroo.com



### Colors / Couleurs

Post / Poteaux: Brown/Brun

Accent Color / Couleur complémentaire:  
 Orange/Orange

1 Color panel / Panneaux 1 couleur: Green/Vert

2 colors panel / Panneaux 2 couleurs :  
 Green & Tan/Vert et beige

Slide / Glissoire: Orange/Orange

Plastic Climbers / Grimpeur Plastique:  
 Green & Tan/Vert et beige

Cable / Cable : NA

Roof / Toit : NA

### Kroll-183

Min. Protective Surface Required / Surface de protection min. requise :  
 10.9 m (35'-10") x 8.4 m (27'-7")

Equipment Dimensions / Dimensions de l'équipement :  
 7.3 m (23'-10") x 4.8 m (15'-7")

Approval date: 05/02/2018

Rev: 00

Initial: TLG

CAN/CSA-Z614-xx  
 xx: Last Edition Published/  
 Dernière édition publiée

Recommended Ages / Âges recommandés :  
 18 months to 12 years old / 18 mois à 12 ans

Capacity / Peut accueillir :  
 up to 25 children / Jusqu'à 25 enfants





23 ch. Boom Lane, Unit/Unité E  
 Industrial Park/Parc industriel  
 Atholville, New/Novveau-Brunswick  
 Canada, E3N 4E8  
 Tel/tél. : 1-888-212-1411/Fax/télééc. : 1-888-789-0987  
 www.kangoroo.com

|  |  |   |   |
|--|--|---|---|
| <b>Kroll-183</b>   | Min. Protective Surface Required / Surface de protection min. requise :<br>10.9 m (35'-10") x 8.4 m (27'-7") | Equipment Dimensions / Dimensions de l'équipement :<br>7.3 m (23'-10") x 4.8 m (15'-7") | Approval date: 05/02/2018<br>Rev: 00<br>Initial: TLG                                  |
| CAN/CSA-Z614-xx<br>xx: Last Edition Published/<br>Dernière édition publiée | Recommended Ages / Âges recommandés :<br>18 months to 12 years old / 18 mois à 12 ans                        | Capacity / Peut accueillir :<br>up to 25 children / Jusqu'à 25 enfants                  |  |

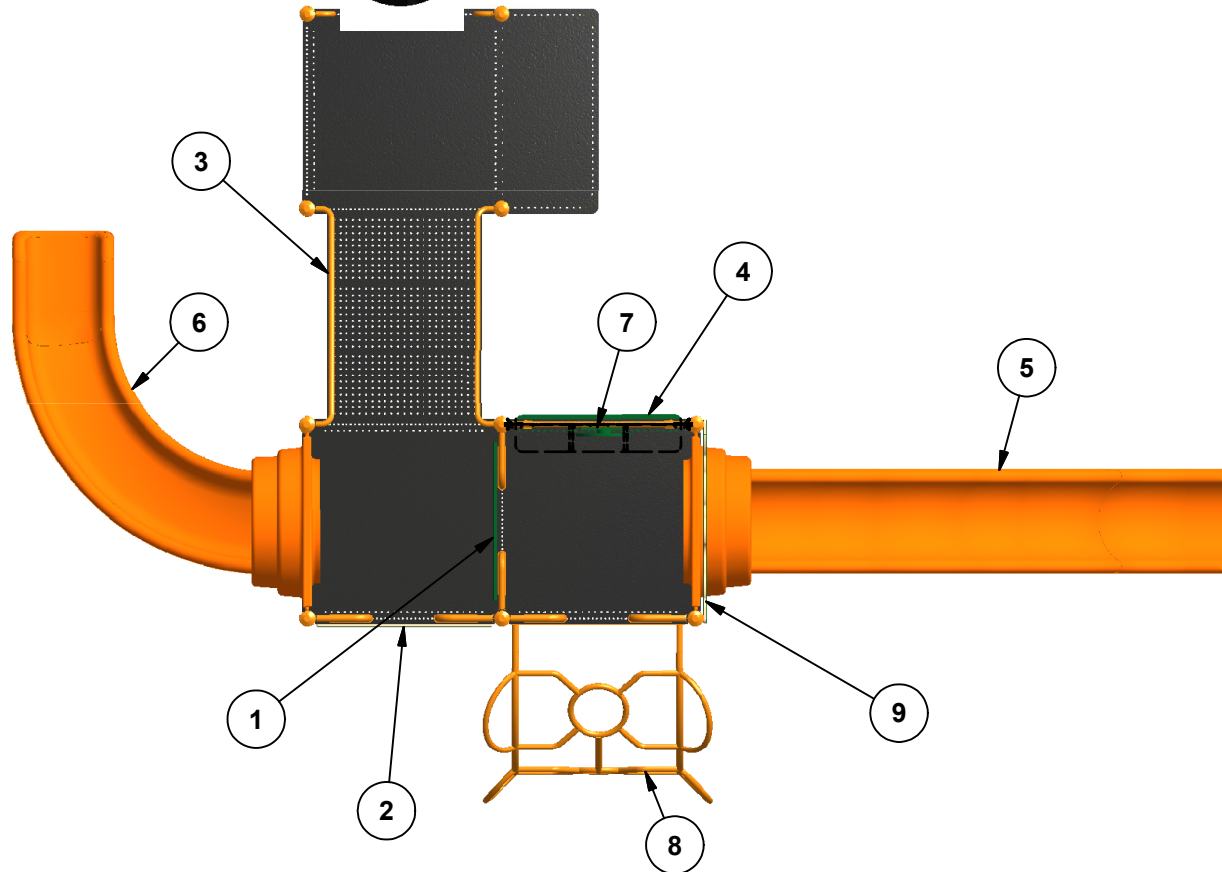

23 ch. Boom Lane, Unit/Unité E  
 Industrial Park/Parc industriel  
 Atholville, New/Nouveau-Brunswick  
 Canada, E3N 4E8  
 Tel/tél. : 1-888-212-1411/Fax/télééc. : 1-888-789-0987  
 www.kangoroo.com

Legend / Légende

| ITEM | QTY | Description  | PART # / # PIECE |
|------|-----|--|------------------|
| 1    | 1   | Ladder Panel 24" / Panneau échelle 24"                   | LP-24            |
| 2    | 1   | Nature Climb 48"/ Grimpeur theme nature 48"              | NAT-CL-48        |
| 3    | 1   | Transfer Station / Marches accessibles                   | TRS-ST-SQ-FR-48  |
| 4    | 1   | KG Counter Panel/Panneau comptoir KG                     | KG-Counter       |
| 5    | 1   | Wavy Double Wall Slide 72"/glissoire simple en vague 72" | FS-6DWWS         |
| 6    | 1   | Curved Slide 48" / Glissoire courbée 48"                 | 4CURVED          |
| 7    | 1   | Car Panel / Panneau auto                                 | AC-CAR           |
| 8    | 1   | Bowtie Climber 72"/ Grimpeur Noeud Papillon 72"          | FS-BWT-72        |
| 9    | 1   | Nature Canopy / Canopée                                  | NAT-CNP          |

**Kroll-183**

CAN/CSA-Z614-xx  
 xx: Last Edition Published/  
 Dernière édition publiée

Min. Protective Surface Required / Surface de protection min. requise :  
 10.9 m (35'-10") x 8.4 m (27'-7")

Recommended Ages / Âges recommandés :  
 18 months to 12 years old / 18 mois à 12 ans

Equipment Dimensions / Dimensions de l'équipement :  
 7.3 m (23'-10") x 4.8 m (15'-7")

Capacity / Peut accueillir :  
 up to 25 children / Jusqu'à 25 enfants

Approval date: 05/02/2018  
 Rev: 00  
 Initial: TLG





Access to All /  
Accessible

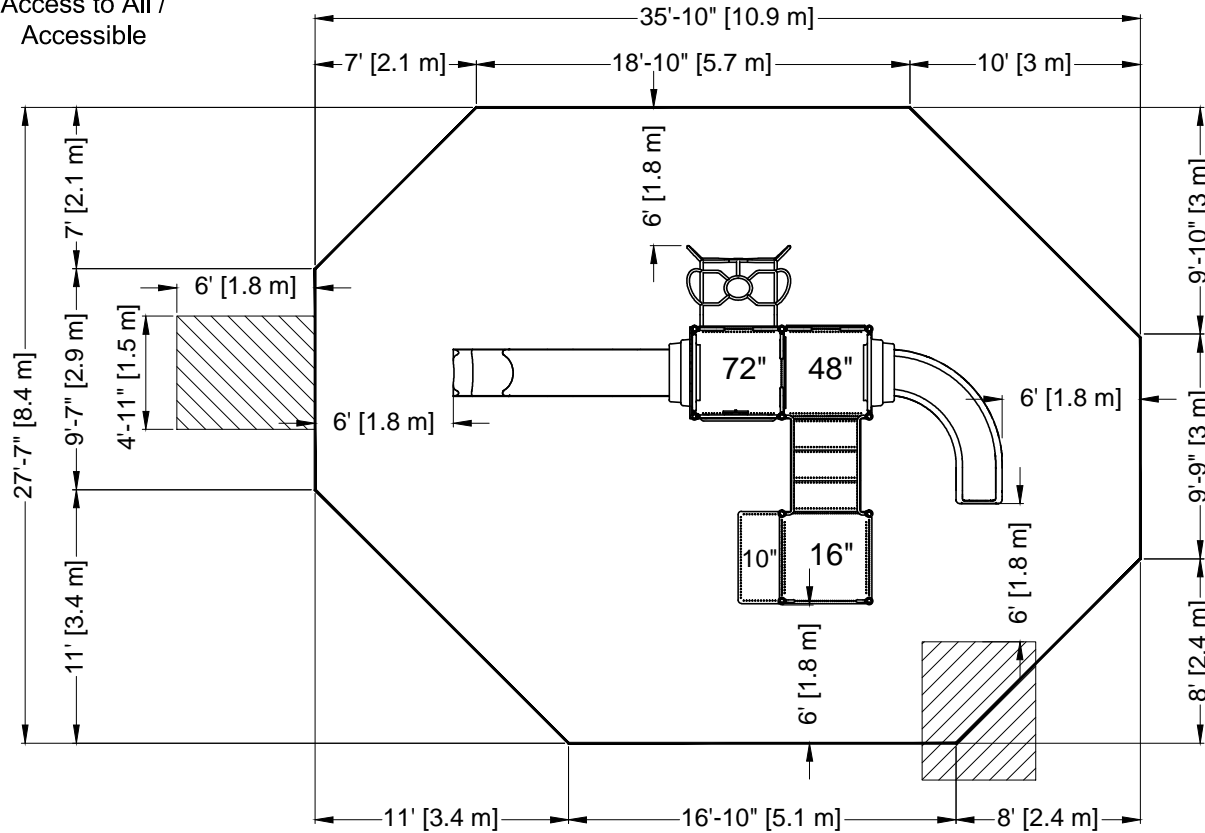

PLATFORM HEIGHTS  
HAUTEURS DE PLATEFORME

|              |              |
|--------------|--------------|
| 10" = 254MM  | 60" = 1524MM |
| 12" = 305MM  | 72" = 1829MM |
| 24" = 609MM  | 84" = 2134MM |
| 36" = 915MM  | 96" = 2438MM |
| 48" = 1219MM |              |



23 ch. Boom Lane, Unit/Unité E, Industrial Park/Parc industriel  
Atholville, New/Nouveau-Brunswick  
Canada, E3N 4E8  
Tel/tél. : 1-888-212-1411 - Fax/télec. : 1-888-789-0987  
contact@kangoroo.com / www.kangoroo.com

**ZONE DE PROTECTION:**

Chaque équipement doit avoir une zone de protection constituée d'une surface sans obstacle qui se prolonge dans toutes les directions à partir du périmètre de l'équipement. Cette zone doit contenir un revêtement de surface (gravillon, sable, etc...) avec une capacité d'amortissement selon les normes CSA-Z614. Sauf avis contraire.

Zone de protection minimum requise:

$$10.9 \text{ m (35'-10")}$$

$$\times$$

$$8.4 \text{ m (27'-7")}$$

- Aire : 76.27 m ca.  
(820.98 pi. ca.)
- Périmètre : 32.32 m  
(106'-0")

**PROTECTIVE SURFACING ZONE :**

Each equipment shall have a protective surfacing zone that consist of obstacle-free surfacing surrounding the equipment. This zone shall contain shock absorbing material (pea gravel, sand, etc...) that comply with CSA-Z614. Unless noted otherwise.

Minimum  
Protective Surfacing Zone required:

$$10.9 \text{ m (35'-10")}$$

$$\times$$

$$8.4 \text{ m (27'-7")}$$

- Surface: 76.27 sq. m  
(820.98 sq. ft.)
- Perimeter: 32.32 m  
(106'-0")

**MÉTHODES D'INSTALLATION**

1

**DANS LE BÉTON:**

- Quantité de Sonotube de 12" Ø x 12' : 3

Béton :  
- 0.92 m. cu.  
( 1.2 vge cu.)



**INSTALLATION METHODS**

1

**CONCRETE:**

- Quantity of Sonotube of 12" Ø x 12' : 3

Concrete:  
- 0.92 cu. m.  
(1.2 cu. yd.)



2

**SYSTÈME AUTO-PORTANT:**

Qté charpentes: **6**  
Béton :  
- 0 m. cu.  
(0 vge cu.)



2

**FREE-STANDING SYSTEM:**

Frame QTY: **6**  
Concrete:  
- 0 cu. m.  
(0 cu. yd.)



**Attention :**

**AIRE DE CIRCULATION LIBRE:**

Aire dégagée d'obstacle qui se prolonge sur au moins 1.8m (70.87") au delà de la zone de protection. Voir dessin pour les détails.

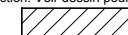

**Warning:**

**NO-ENCROACHMENT ZONE :**

Obstacle-free zone extending at least 1.8m (70.87") beyond the protective surfacing zone. See drawing for details.

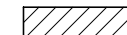

**Kroll-183**

CAN/CSA-Z614-xx  
xx: Last Edition Published /  
Dernière édition publiée

Equipment Dimensions / Dimensions de l'équipement :  
7.3 m (23'-10") x 4.8 m (15'-7")

Capacity / Peut accueillir :  
up to 25 children / Jusqu'à 25 enfants

Recommended Ages / Âges recommandés :  
18 months to 12 years old  
18 mois à 12 ans

Fall Height /  
Hauteur de chute:  
2.89 m (9'-6")

Approval date: 05-02-2018  
Rev: 00  
Initial: TLG

