



23 ch. Boom Lane, Unit/Unité E Industrial
 Park/Parc industriel Atholville, New/Nouveau-
 Brunswick Canada, E3N 4E8
 Tel/tél. : 1-888-212-1411/Fax/télé. : 1-888-
 789-0987 www.kangoroo.com

Colors / Couleurs

Post / Poteaux:

Accent Color / Couleur complémentaire:

1 Color panel / Panneaux 1 couleur:

2 colors panel / Panneaux 2 couleurs :

Slide / Glissoire:

Plastic Climbers / Grimpeur Plastique:

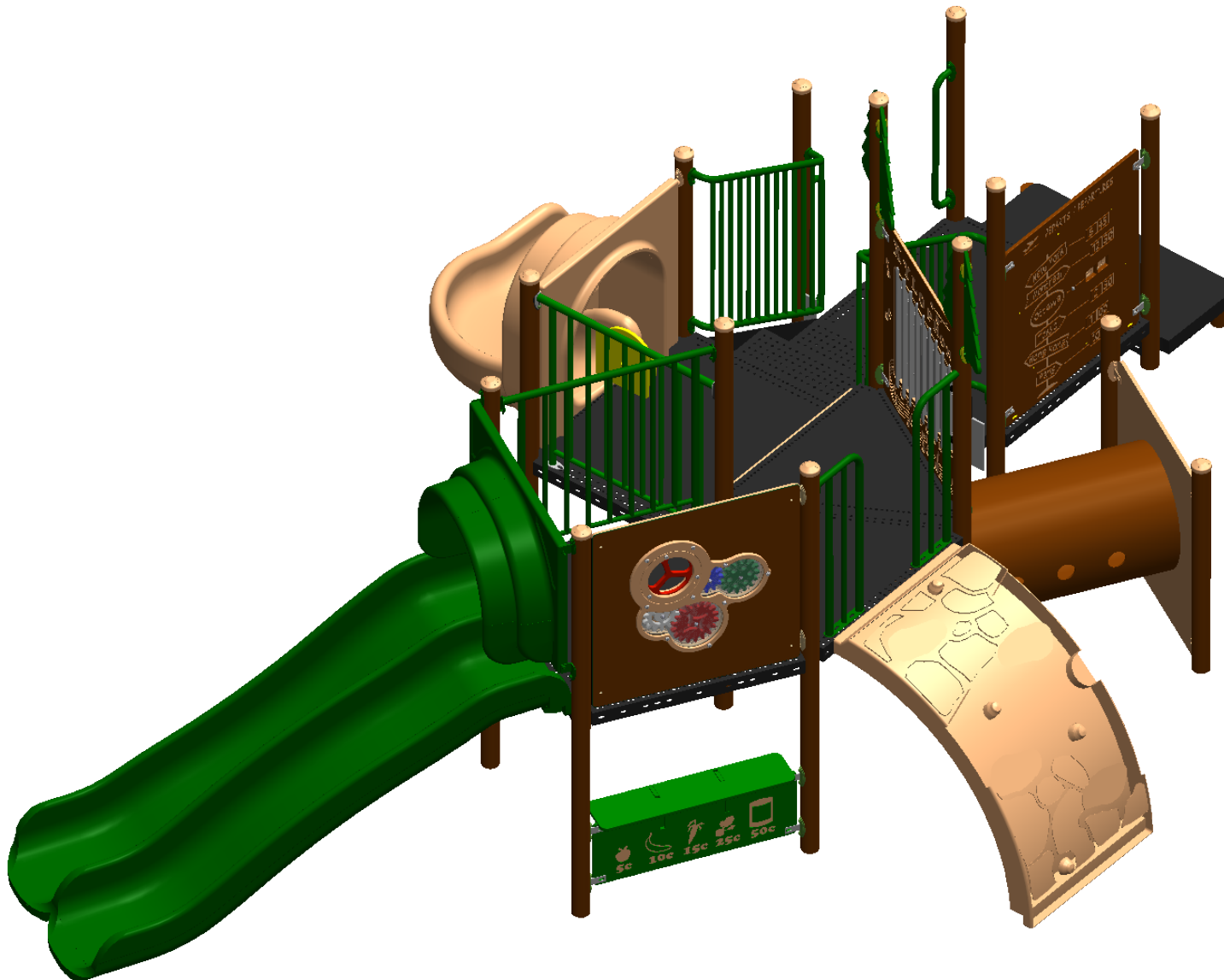

Kroll-179_M1

Min. Protective Surface Required / Surface de protection min. requise
 11.1 m (36' - 5") x 8.4 m (27' - 6")

Equipment Dimensions / Dimensions de l'équipement :
 7.5 m (15' - 9") x 4.8 m (24' - 7.28")

Approval date: 2023-03-02

Rev: 00

CAN/CSA-Z614

Recommended Ages / Âges recommandés :
 18 months to 5 years old / 18 mois à 5 ans

Capacity / Peut accueillir : up to 30 children / Jusqu'à 30 enfants

Initial: B.D



23 ch. Boom Lane, Unit/Unité E Industrial
 Park/Parc industriel Atholville, New/Nouveau-
 Brunswick Canada, E3N 4E8
 Tel/tél. : 1-888-212-1411/Fax/télé. : 1-888-
 789-0987 www.kangaroo.com

Colors / Couleurs

Post / Poteaux:

Accent Color / Couleur complémentaire:

1 Color panel / Panneaux 1 couleur:

2 colors panel / Panneaux 2 couleurs :

Slide / Glissoire:

Plastic Climbers / Grimpeur Plastique:



Kroll-179_M1

Min. Protective Surface Required / Surface de protection min. requise
 11.1 m (36' - 5") x 8.4 m (27' - 6")

Equipment Dimensions / Dimensions de l'équipement :
 7.5 m (15' - 9") x 4.8 m (24' - 7.28")

Approval date: 2023-03-02

Rev: 00

Initial: B.D

CAN/CSA-Z614

Recommended Ages / Âges recommandés :
 18 months to 5 years old / 18 mois à 5 ans



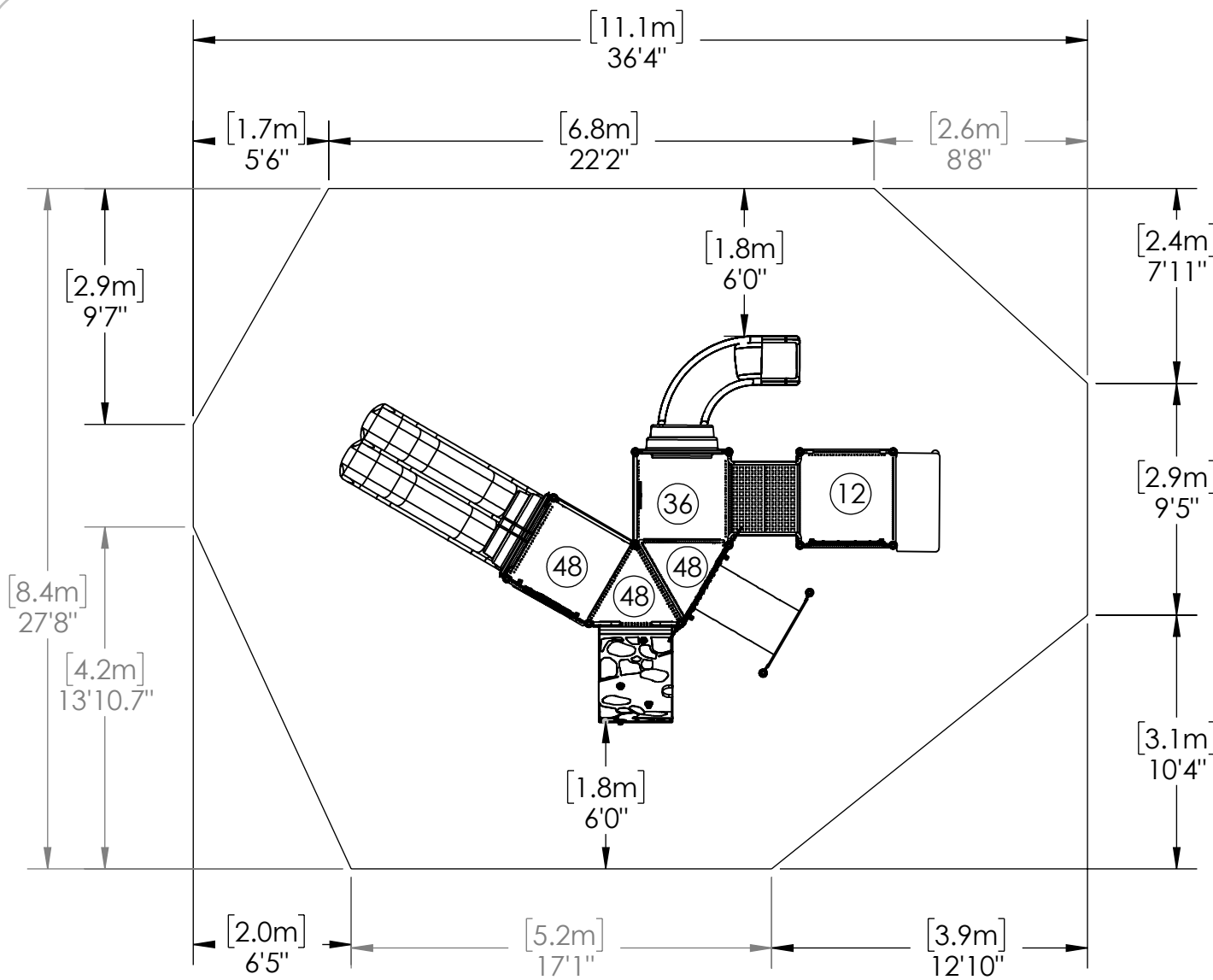

Capacity / Peut accueillir : up to 30 children / Jusqu'à 30 enfants

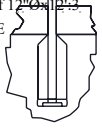

PLATFORM HEIGHTS
HAUTEURS DE PLATEFORME

12" = 305MM	24" = 609MM
36" = 915MM	48" = 1219MM
60" = 1524MM	72" = 1829MM
84" = 2134MM	96" = 2438MM

23 ch. Boom Lane, Unit/Unité E Industrial Park/Parc industriel
 Atholville, New/Nouveau-Brunswick Canada, E3N 4E8
 Tel/tél. : 1-888-212-1411/Fax/télé. : 1-888-789-0987
 www.kangoroo.com

<p>ZONE DE PROTECTION: Chaque équipement doit avoir une zone de protection constituée d'une surface sans obstacle qui se prolonge dans toutes les directions à partir du périmètre de l'équipement. Cette zone doit contenir un revêtement de surface (gravillon, sable, etc...) avec une capacité d'amortissement selon les normes CSA-Z614. Sauf avis contraire.</p> <p>Zone de protection <u>minimum</u> requise: 11.1 m (36'-5") x 8.4 m (27'-8") - Surface: 93.24 sq. m (1003.627 sq. ft.) - Perimeter: 39 m (127'-11")</p>	<p>PROTECTIVE SURFACING ZONE : Each equipment shall have a protective surfacing zone that consist of obstacle-free surfacing surrounding the equipment. This zone shall contain shock absorbing material (pea gravel, sand, etc...) that comply with CSA-Z614. Unless noted otherwise. Minimum Protective Surfacing Zone required: 11.1 m (36'-5") x 8.4 m (27'-6") - Surface: 93.24 sq. m (1003.627 sq. ft.) - Perimeter: 39 m (127'-11")</p>
<p>MÉTHODES D'INSTALLATION 1</p> <p>DANS LE BÉTON: - Quantité de Sonotube de 12" Ø x 12' : 3 Béton: - 122m.cu. (1.6vge.cu.)</p> 	<p>INSTALLATION METHODS 1</p> <p>CONCRETE -Quantity of sonotube of 12"Ø x 12': 3 CONCRETE -1.22 cu.m. (1.6cu.yd.)</p> 
<p>SYSTÈME AUTO-PORTANT: Qté charpentes: 7 Béton : - 0.15 cu. (0.2 vge cu.)</p> 	<p>FREE-STANDING SYSTEM: Frame QTY: 7 Concrete: -0.15 cu. m. (-0.2 cu. yd.)</p> 
<p>Attention : AIRE DE CIRCULATION LIBRE: Aire dégagée d'obstacle qui se prolonge sur au moins 1.8m (70.87") au delà de la zone de protection. Voir dessin pour les détails.</p> 	<p>Warning: NO-ENCROACHMENT ZONE: Obstacle-free zone extending at least 1.8m (70.87") beyond the protective surfacing zone. See drawing for details.</p> 

<p>Kroll-179_M1</p>	<p>Recommended Ages / Âges recommandés : 18 months to 5 years old / 18 mois à 5 ans</p>	<p>Equipment Dimensions / Dimensions de l'équipement : 7.4 m (24'-4") x 5.3 m (17'-4")</p>	<p>Fall Height / Hauteur de chute: 2.29 m (7'-6")</p>	<p>Approval date: 2023-03-02 Rev: 00 Initial: B.D</p>
<p>CAN/CSA-Z614</p>	<p>Capacity / Peut accueillir : up to 30 children / Jusqu'à 30 enfants</p>			

MINIMUM EXCAVATION AREA



23 ch. Boom Lane, Unit/Unité E Industrial Park/Parc industriel
 Atholville, New/Nouveau-Brunswick Canada, E3N 4E8
 Tel/tél. : 1-888-212-1411/Fax/télééc. : 1-888-789-0987
 www.kangoroo.com

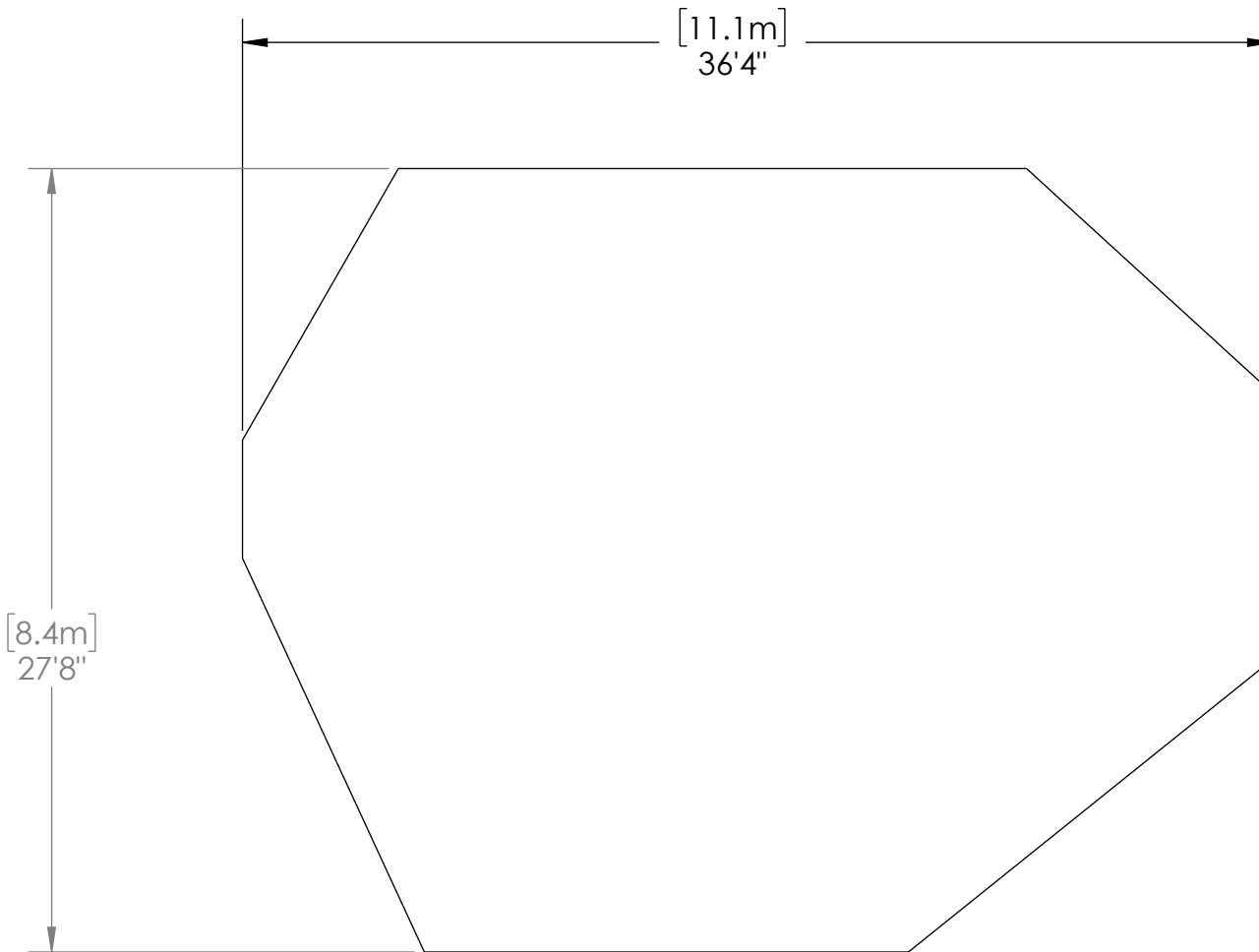

DEPTH OF EXCAVATION VARIES UPON
 TYPE OF PROTECTIVE SURFACING USED
 AND FALL HEIGHT OF THE EQUIPMENT.
 PLEASE CONSULT YOUR PROTECTIVE
 SURFACING PROVIDER

OUR EQUIPMENT IS INTENDED FOR A
 12" OF PROTECTIVE SURFACING.
 DIG 12" OR CONSULT YOUR
 PROTECTIVE SURFACING PROVIDER.

IMPORTANT
 GOOD DRAINAGE IS MANDATORY
 FOR ANY SPACE.
 NOT SHOWN IN THIS DRAWING

KRoll-179

CAN/CSA-Z614

Recommended Ages / Âges recommandés :
 18 months to 5 years old / 18 mois à 5 ans

Equipment Dimensions / Dimensions de
 l'équipement : 7.4 m (24'-4") x 5.3 m (17'-4")

Capacity / Peut accueillir : up to
 30 children / Jusqu'à 30 enfants

Fall Height /
 Hauteur de chute:
 2.29 m (7'-6")

Approval date: 2023-03-02
 Rev: 00
 Initial: B.D

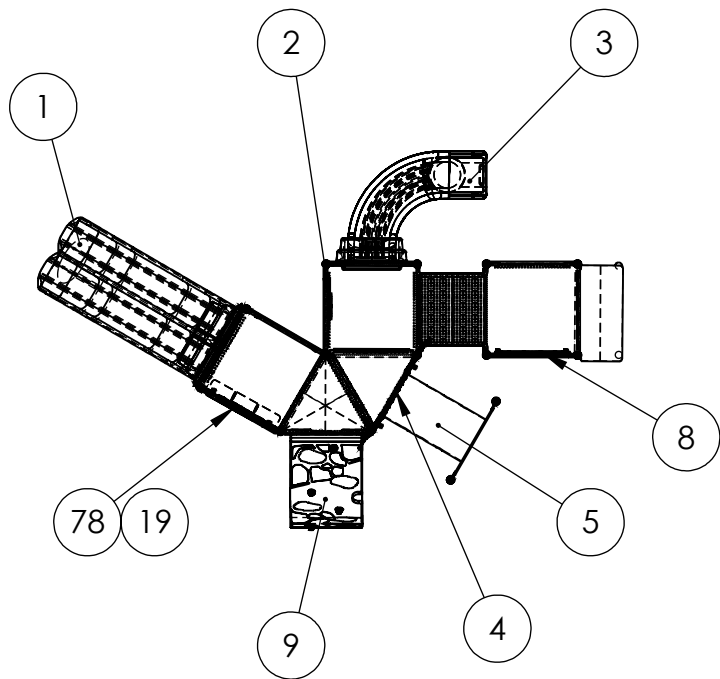

23 ch. Boom Lane, Unit/Unité E Industrial
 Park/Parc industriel Atholville, New/Nouveau-
 Brunswick Canada, E3N 4E8
 Tel/tél. : 1-888-212-1411/Fax/télé. : 1-888-
 789-0987 www.kangaroo.com

Colors / Couleurs
 Post / Poteaux:
 Accent Color / Couleur complémentaire:
 1 Color panel / Panneaux 1 couleur:
 2 colors panel / Panneaux 2 couleurs :
 Slide / Glissoire:
 Plastic Climbers / Grimpeur Plastique:

ITEM NO.	PART NUMBER	DESCRIPTION	QTY.
1	TRIPLE RAIL SLIDE 48	Triple Rail Slide 48" / Glissoire double 48"	1
2	KG-WHEEL_00	KG Steering Wheel/ Volant KG	1
3	3CURVED-N_00	Right Curved Slide 36"/Glissoire courbée a la droite 36"	1
4	Xylophone	KG Xylophone Maze / Panneau xylophone KG	1
5	tunnel-24dia-45L	Tunnel 45"Length/Tunnel 45"Long	1
6	Ice-Cream-shop	KG Ice Cream Shop/ Comptoir crème glacée KG	1
7	TR-TP	TREE TOPPER	4
8	KG-CLOCK	KG clock / KG horloge	1
9	BEDROCK CLIMBER 48	Bedrock Climber / Mur à grimper bedrock	1

Kroll-179_M1

Min. Protective Surface Required / Surface de protection min. requise
 11.1 m (36' - 5") x 8.4 m (27' - 6")

Equipment Dimensions / Dimensions de l'équipement :
 7.5 m (15' - 9") x 4.8 m (24' - 7.28")

Approval date: 2023-03-02

Rev: 00

CAN/CSA-Z614

Recommended Ages / Âges recommandés :
 18 months to 5 years old / 18 mois à 5 ans

Capacity / Peut accueillir : up to 30 children / Jusqu'à 30 enfants

Initial: B.D