



23 ch. Boom Lane, Unit/Unité E
 Industrial Park/Parc industriel
 Atholville, New/Nouveau-Brunswick
 Canada, E3N 4E8
 Tel/tél. : 1-888-212-1411/Fax/télééc. : 1-888-789-0987
 contact@kangoroo.com / www.kangoroo.com

Colors / Couleurs

Post / Poteaux: Purple/Pourpre

Accent Color / Couleur complémentaire:
 Yellow/Jaune

1 Color panel / Panneaux 1 couleur: NA

2 colors panel / Panneaux 2 couleurs :
 Yellow & Black/Jaune et noir

Slide / Glissoire: Yellow & Cyan/Jaune et cyan

Plastic Climbers / Grimpeur Plastique:
 NA

Cable / Cable : NA

Roof / Toît : Cyan/Cyan

Kroll-156

Min. Protective Surface Required / Surface de protection min. requise :
 7.8 m (25'-7") x 7.9 m (25'-10")

Equipment Dimensions / Dimensions de l'équipement :
 4.1m (13'-7") x 4.2 m (13'-10")

Approval date: 06/10/2015

Rev: 01

Initial: TLG

CAN/CSA-Z614-xx
 xx: Last Edition Published/
 Dernière édition publiée

Recommended Ages / Âges recommandés :
 18 months to 5 years old / 18 mois à 5 ans

Capacity / Peut accueillir :
 up to 15 children / Jusqu'à 15 enfants





23 ch. Boom Lane, Unit/Unité E
 Industrial Park/Parc industriel
 Atholville, New/Nouveau-Brunswick
 Canada, E3N 4E8
 Tel/tél. : 1-888-212-1411/Fax/télééc. : 1-888-789-0987
 go@kangaroo.com / www.kangaroo.com



Kroll-156	Min. Protective Surface Required / Surface de protection min. requise : 7.8 m (25'-7") x 7.9 m (25'-10")	Equipment Dimensions / Dimensions de l'équipement : 4.1m (13'-7") x 4.2 m (13'-10")	Approval date: 06/10/2015 Rev: 01 Initial: TLG
CAN/CSA-Z614-xx xx: Last Edition Published/ Dernière édition publiée	Recommended Ages / Âges recommandés : 18 months to 5 years old / 18 mois à 5 ans	Capacity / Peut accueillir : up to 15 children / Jusqu'à 15 enfants	



23 ch. Boom Lane, Unit/Unité E
 Industrial Park/Parc industriel
 Atholville, New/Nouveau-Brunswick
 Canada, E3N 4E8
 Tel/tél. : 1-888-212-1411/Fax/télééc. : 1-888-789-0987
 go@kangaroo.com / www.kangaroo.com

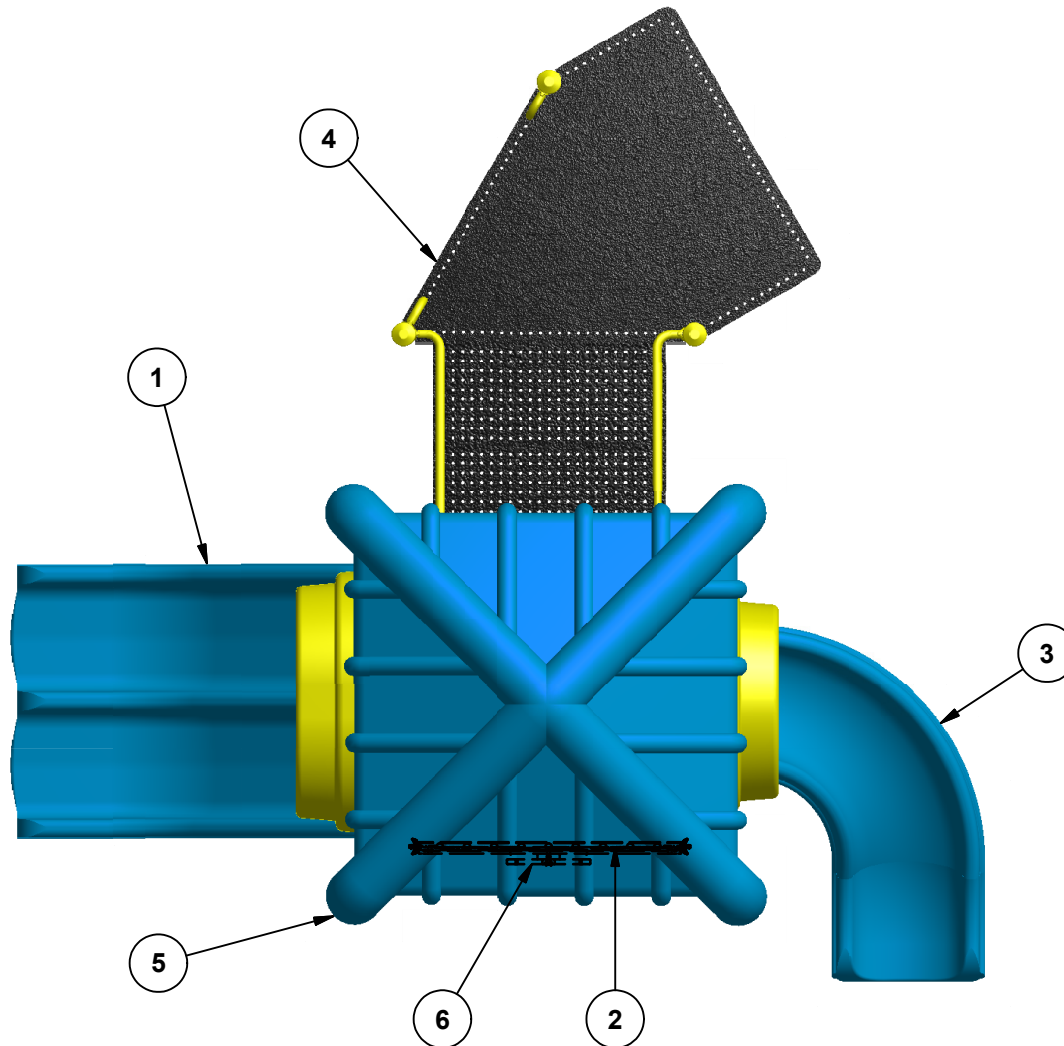

Legend / Légende

ITEM	QTY	Description	PART # / # PIECE
1	1	Triple Rail Slide 36"/Glissoire double 36"	3TRS
2	1	KG Bee-Maze / Panneau Abeille KG	KG-Bmaze
3	1	90° Curved slide 36"/ Glissoire courbée 90°, 36"	3CURVED,N
4	1	Transfer Station/Marches accessibles	TRANST-36
5	1	Double Wall Pyramid Roof/Toit pyramide a double paroi	PYRA-RF
6	1	Acc. Car Panel / Panneau auto acc.	AC-ASTW

Kroll-156

Min. Protective Surface Required / Surface de protection min. requise :
 7.5 m (24'-8") x 7.5 m (24'-8")

Equipment Dimensions / Dimensions de l'équipement :
 4.1m (13'-7") x 4.2 m (13'-10")

Approval date: 06/10/2015

CAN/CSA-Z614-xx
 xx: Last Edition Published/
 Dernière édition publiée

Recommended Ages / Âges recommandés :
 18 months to 5 years old / 18 mois à 5 ans

Capacity / Peut accueillir :
 up to 15 children / Jusqu'à 15 enfants

Rev: 01
 Initial: TLG





23 ch. Boom Lane, Unit/Unité E, Industrial Park/Parc industriel
 Atholville, New/Nouveau-Brunswick
 Canada, E3N 4E8
 Tel/tél. : 1-888-212-1411 - Fax/télec. : 1-888-789-0987
 contact@kangoroo.com / www.kangoroo.com

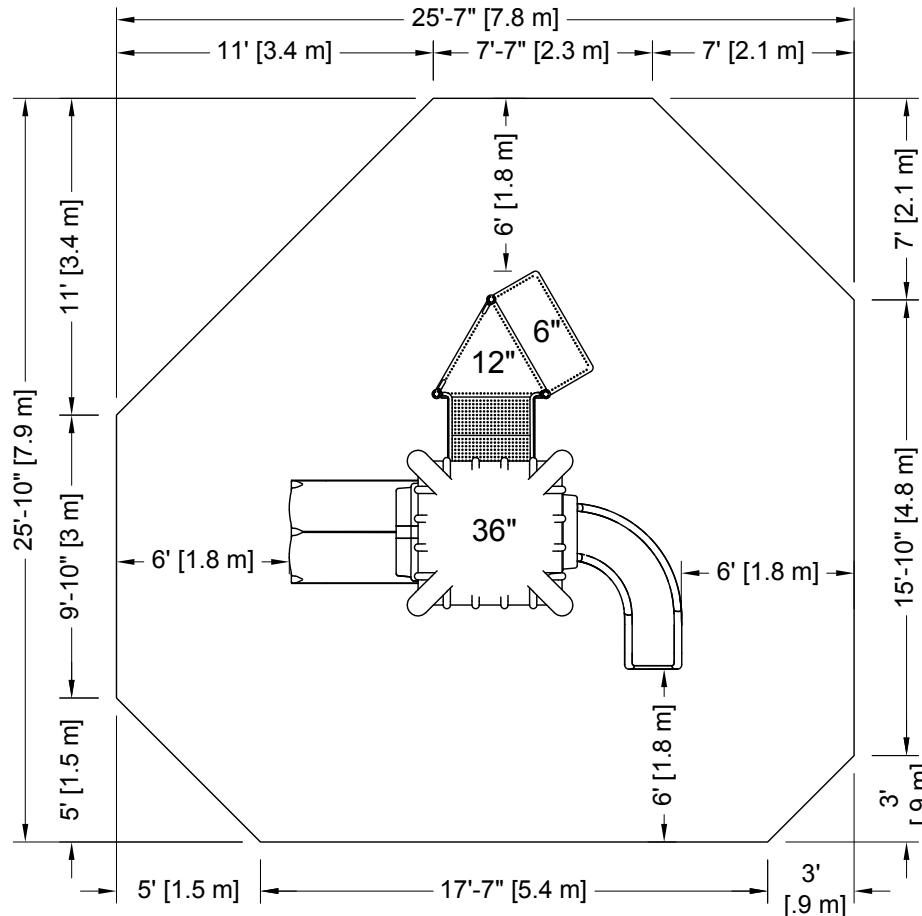

PLATFORM HEIGHTS
HAUTEURS DE PLATEFORME

6" = 152MM	60" = 1524MM
12" = 305MM	72" = 1829MM
24" = 609MM	84" = 2134MM
36" = 915MM	96" = 2438MM
48" = 1219MM	

ZONE DE PROTECTION:

Chaque équipement doit avoir une zone de protection constituée d'une surface sans obstacle qui se prolonge dans toutes les directions à partir du périmètre de l'équipement. Cette zone doit contenir un revêtement de surface (gravillon, sable, etc...) avec une capacité d'amortissement selon les normes CSA-Z614. Sauf avis contraire.

Zone de protection minimum requise:

$$7.8 \text{ m (25'-7")}$$

$$\times$$

$$7.9 \text{ m (25'-10")}$$

- Aire : 51.95 m ca. (559.25 pi. ca.)
- Périmètre : 26.82 m (88'-0")

PROTECTIVE SURFACING ZONE :

Each equipment shall have a protective surfacing zone that consist of obstacle-free surfacing surrounding the equipment. This zone shall contain shock absorbing material (pea gravel, sand, etc...) that comply with CSA-Z614. Unless noted otherwise.

Minimum

Protective Surfacing Zone required:

$$7.8 \text{ m (25'-7")}$$

$$\times$$

$$7.9 \text{ m (25'-10")}$$

- Surface: 51.95 sq. m (559.25 sq. ft.)
- Perimeter: 26.82 m (88'-0")

MÉTHODES D'INSTALLATION

1

DANS LE BÉTON:

- Quantité de Sonotube de 12" Ø x 12" : 2

Béton :
 - 0.69 m. cu. (0.9 vge cu.)



1

CONCRETE:

- Quantity of Sonotube of 12" Ø x 12": 2

Concrete:
 - 0.69 cu. m. (0.9 cu. yd.)

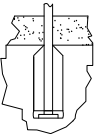

2

SYSTÈME AUTO-PORTANT:

Qté charpentes: 5

Béton :
 - 0 m. cu. (0 vge cu.)

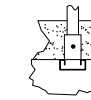

2

FREE-STANDING SYSTEM

Frame QTY: 5

Concrete:
 - 0 cu. m. (0 cu. yd.)

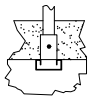

Attention :
AIRE DE CIRCULATION LIBRE:

Aire dégagée d'obstacle qui se prolonge sur au moins 1.8m (70.87") au delà de la zone de protection. Voir dessin pour les détails.

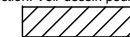

Warning:
NO-ENCROACHMENT ZONE

Obstacle-free zone extending at least 1.8m (70.87") beyond the protective surfacing zone. See drawing for details.



Kroll-156

CAN/CSA-Z614-xx
 xx: Last Edition Published /
 Dernière édition publiée

Equipment Dimensions / Dimensions de l'équipement :
 4.1 m (13'-7") x 4.2 m (13'-10")

Capacity / Peut accueillir :
 up to 15 children / Jusqu'à 15 enfants

Recommended Ages / Âges recommandés :
 18 months to 5 years old
 18 mois à 5 ans

Fall Height /
 Hauteur de chute:
 1.98m (6'-6")

Approval date: 06-10-2015
 Rev: 01
 Initial: TLG

