

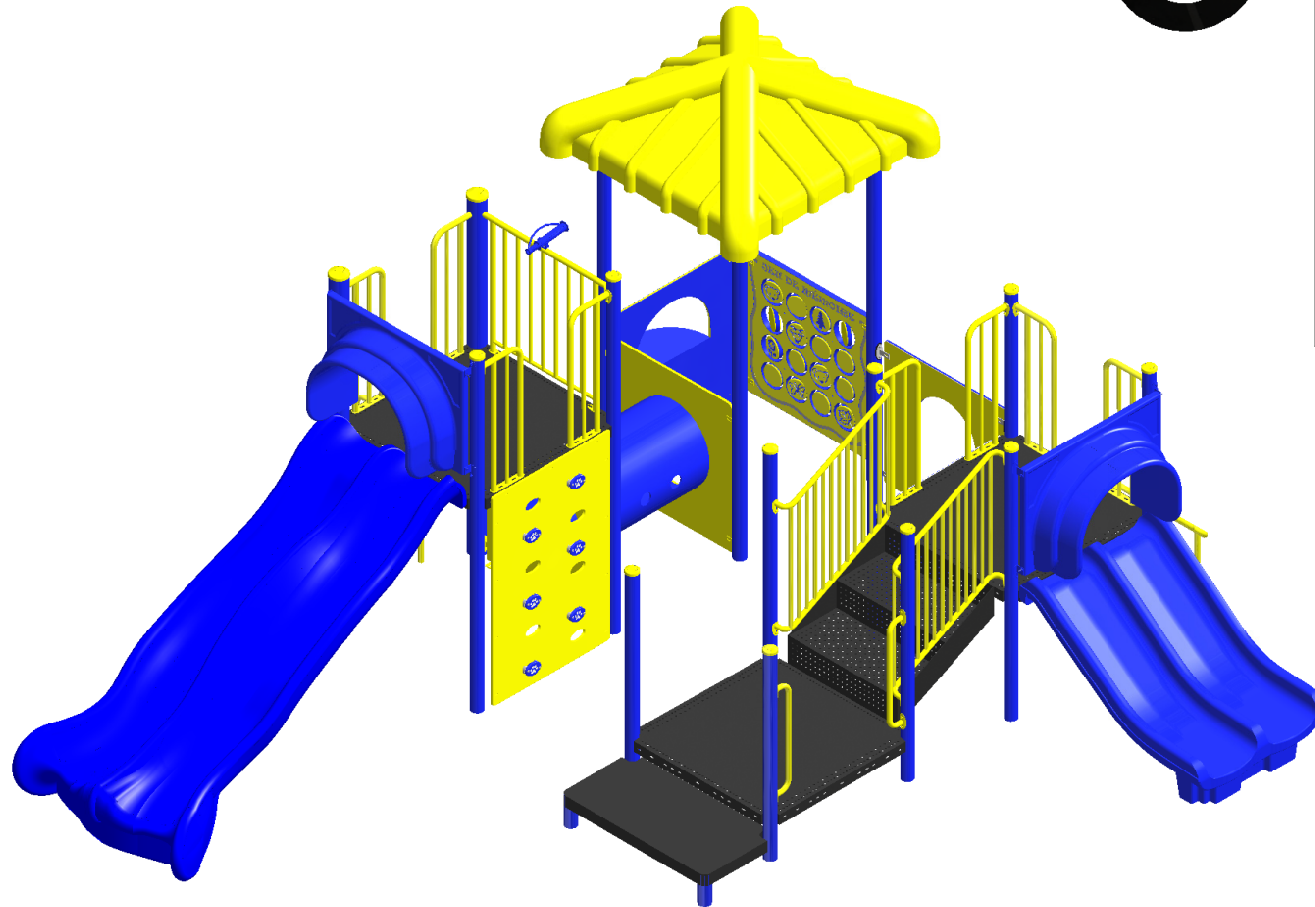

23 ch. Boom Lane, Unit/Unité E, Industrial Park/Parc industriel
 Atholville, New-Brunswick, Canada, E3N 4E8
 Tel/tél. : 1-888-212-1411, Fax. : 1-888-789-0987
 contact@kangaroo.com / www.kangaroo.com



Colors / Couleurs

Post / Poteaux: Blue/Bleu

Accent Color / Couleur complémentaire:
 Yellow/ Jaune

1 Color panel / Panneaux 1 couleur: Yellow/ Jaune

2 colors panel / Panneaux 2 couleurs :
 Yellow & Blue/ Jaune et Bleu

Slide / Glissoire: Blue/Bleu

Plastic Climbers / Grimpeur Plastique:
 Yellow/ Jaune

Cable / Cable : NA

Roof / Toît : Yellow/ Jaune

Kroll-151M1

Min. Protective Surface Required / Surface de protection min. requise :
 10.4 m (34'-3") x 8.8 m (29'-0")

Equipment Dimensions / Dimensions de l'équipement :
 6.8 m (22'-3") x 5.2 m (17'-0")

Approval date: 09/03/2020

Rev: 00

Initial: TLG

CAN/CSA-Z614-xx
 xx: Last Edition Published/
 Dernière édition publiée

Recommended Ages / Âges recommandés :
 18 months to 12 years old / 18 mois à 12 ans

Capacity / Peut accueillir :
 up to 40 children / Jusqu'à 40 enfants





23 ch. Boom Lane, Unit/Unité E
 Industrial Park/Parc industriel
 Atholville, New/Nouveau-Brunswick
 Canada, E3N 4E8
 Tel/tél. : 1-888-212-1411/Fax/télééc. : 1-888-789-0987
 www.kangaroo.com

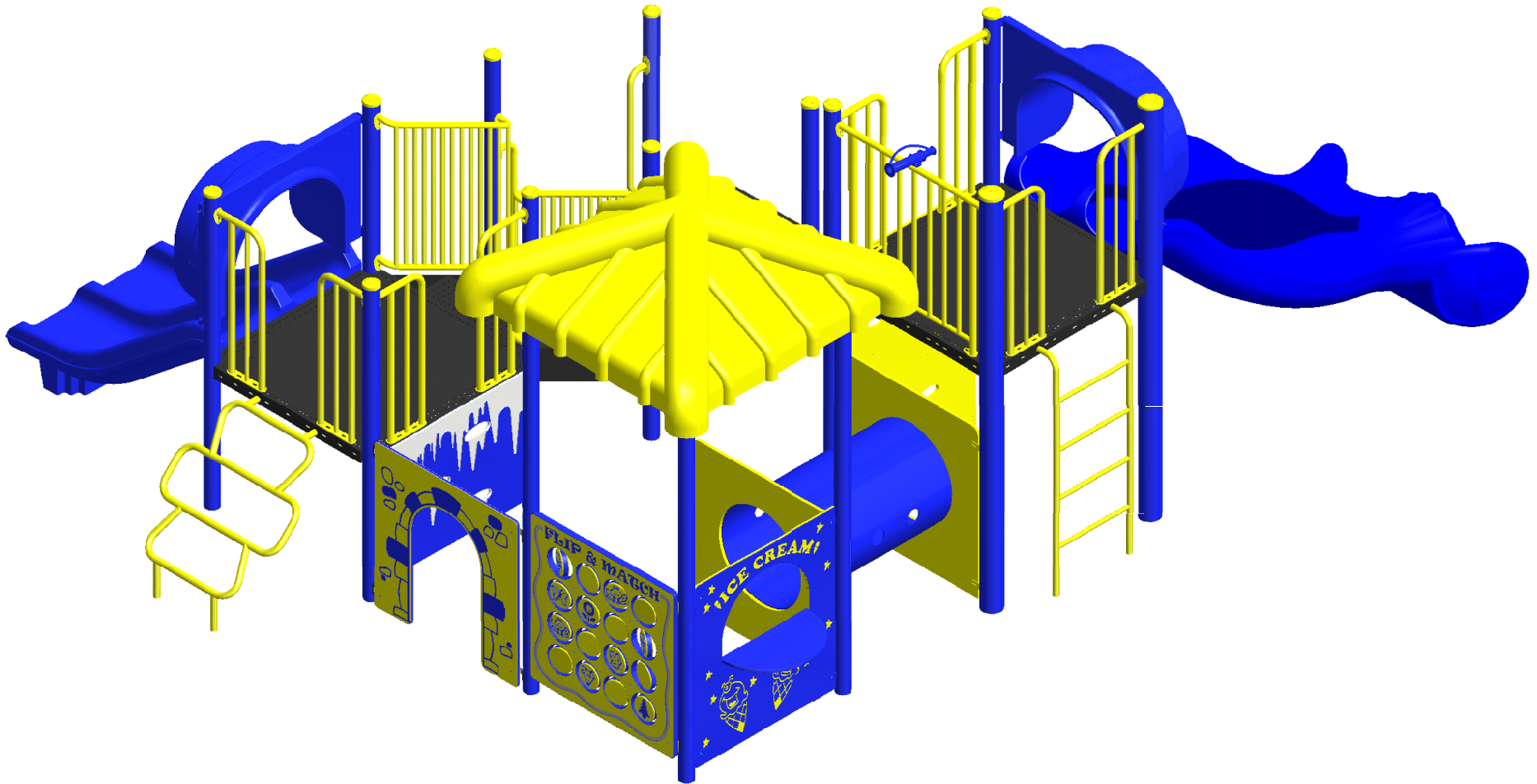

Kroll-151M1	Min. Protective Surface Required / Surface de protection min. requise : 10.4 m (34'-3") x 8.8 m (29'-0")	Equipment Dimensions / Dimensions de l'équipement : 6.8 m (22'-3") x 5.2 m (17'-0")	Approval date: 09/03/2020 Rev: 00 Initial: TLG
CAN/CSA-Z614-xx xx: Last Edition Published/ Dernière édition publiée	Recommended Ages / Âges recommandés : 18 months to 12 years old / 18 mois à 12 ans	Capacity / Peut accueillir : up to 40 children / Jusqu'à 40 enfants	



23 ch. Boom Lane, Unit/Unité E
 Industrial Park/Parc industriel
 Atholville, New/Nouveau-Brunswick
 Canada, E3N 4E8
 Tel/tél. : 1-888-212-1411/Fax/télééc. : 1-888-789-0987
 www.kangaroo.com

Legend / Légende

ITEM	QTY	Description	PART # / # PIECE
1	1	Vertical ChALLENGER 60"/ Défi vertical 60"	V-CHA-60
2	1	Telescope Panel / Panneau télescope	AC-TSCOPE
3	1	Deck to Deck Tunnel / Tunnel plateforme à plateforme	DTD-TUN-24Dia
4	1	Double Wall Pyramid Roof/toit pyramide a double paroi	PYRA-RF
5	1	KG Castle Entrance / Entrée de Château KG	KG-Castle
6	1	Triple Rail Slide 36"/ Glissoire double 36"	FS-3TRS
7	1	Ice Climber 36"/ Escaladeur de glace 36"	ICE-CL-36
8	1	KG Memory Game / Jeux de mémoire KG	KG-Memory
9	1	KG Ice Cream Shop/ Comptoir crème glacée KG	KG-IcCrmSh
10	1	Duo-Slide 60"/ Glissoire double "Duo-Slide" 60"	FS-5TRS
11	1	Transfer Station 36"/ Marches accessibles 36"	TRANST-36
12	1	Candy Climber 36"/ Grimpeur bonbon 36"	FS-CAN-CL-36
13	1	Ground to Deck Rung Ladder 60"/ Échelle à barreaux sol à plateforme 60"	FS-RG-LA-GTD-60

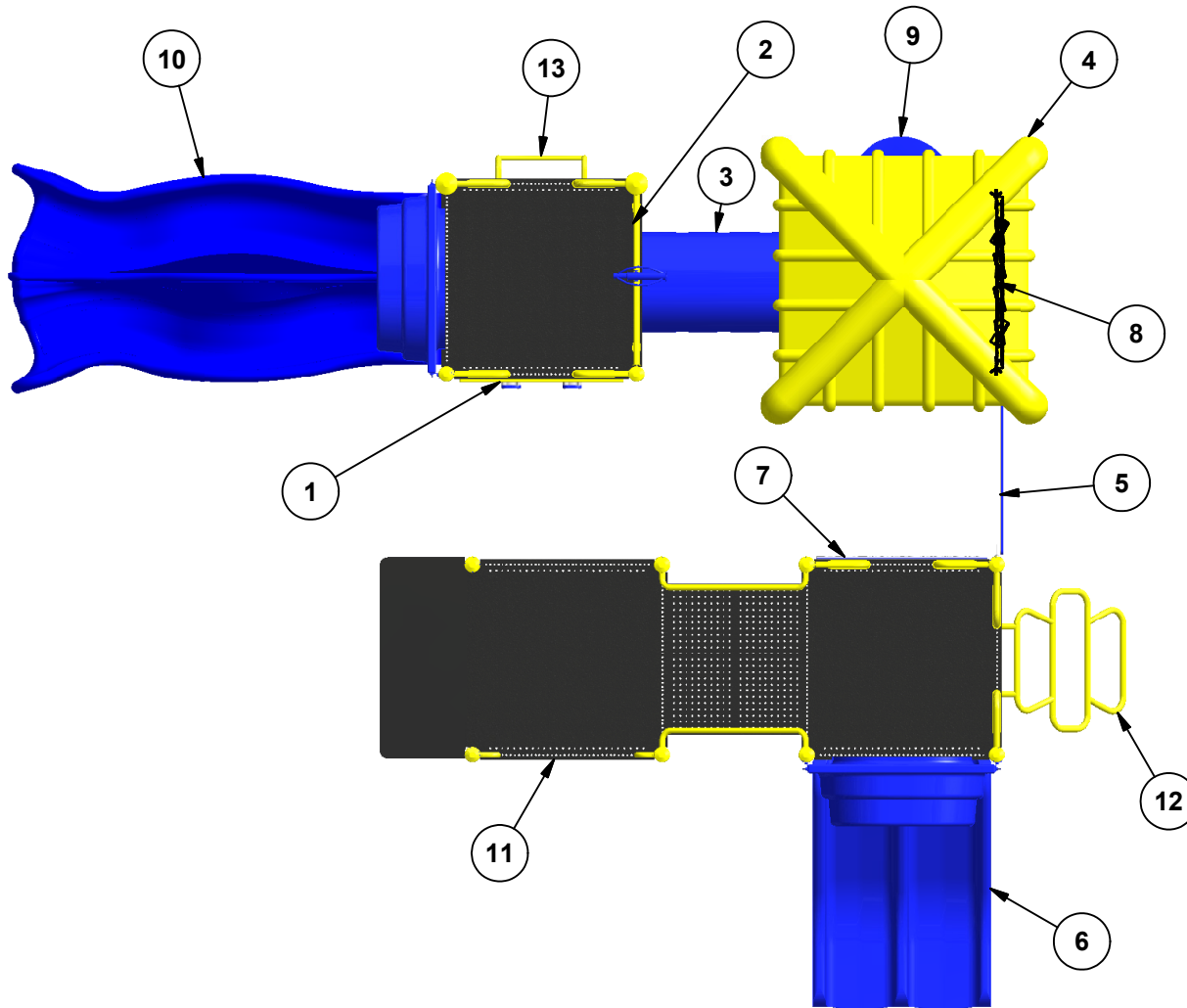

Kroll-151M1

Min. Protective Surface Required / Surface de protection min. requise :
 10.4 m (34'-3") x 8.8 m (29'-0")

Equipment Dimensions / Dimensions de l'équipement :
 6.8 m (22'-3") x 5.2 m (17'-0")

Approval date: 09/03/2020

Rev: 00

Initial: TLG

CAN/CSA-Z614-xx
 xx: Last Edition Published/
 Dernière édition publiée

Recommended Ages / Âges recommandés :
 18 months to 12 years old / 18 mois à 12 ans

Capacity / Peut accueillir :
 up to 40 children / Jusqu'à 40 enfants



