

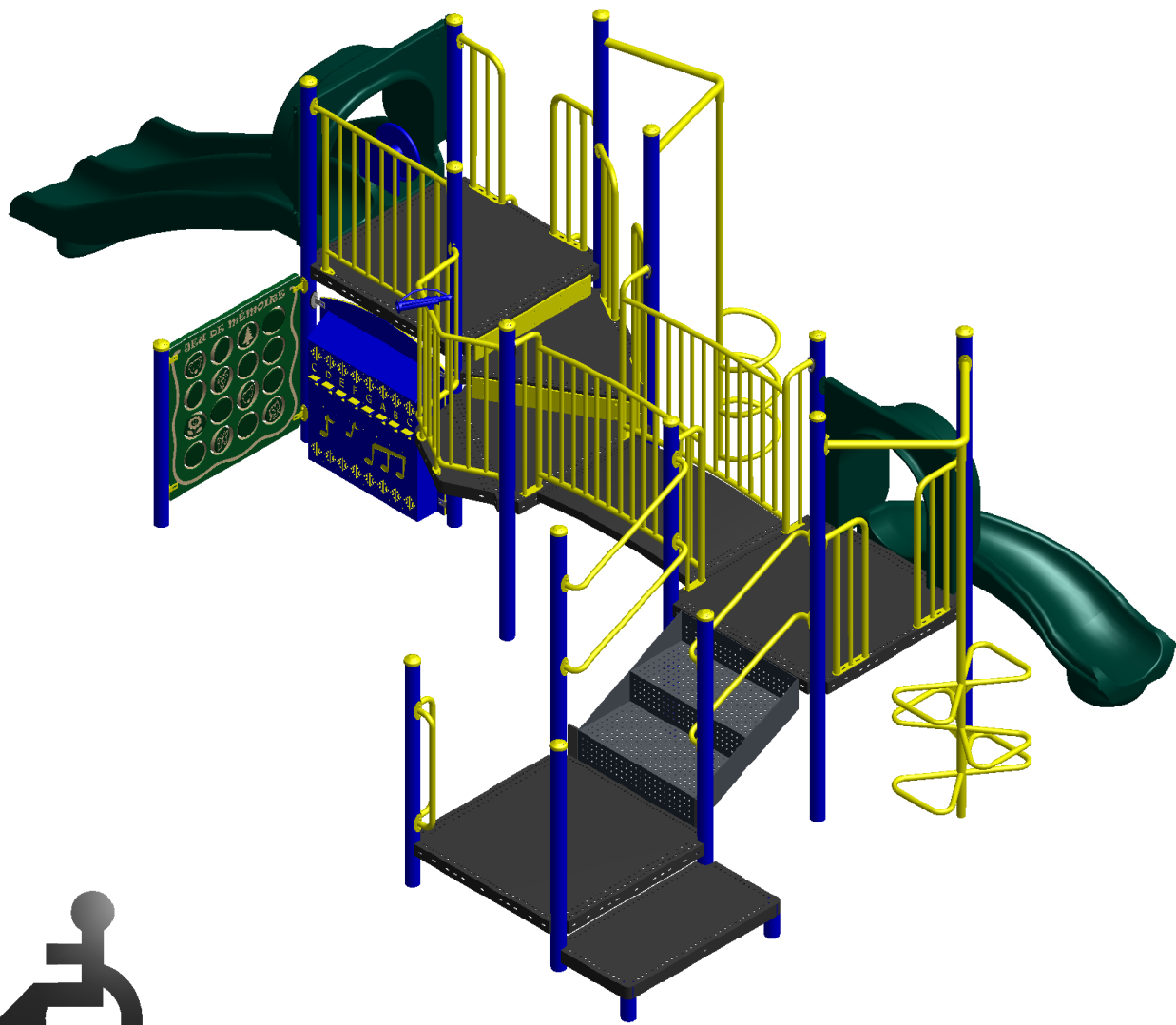



23 ch. Boom Lane, Unit/Unité E  
 Industrial Park/Parc industriel  
 Atholville, New/Nouveau-Brunswick  
 Canada, E3N 4E8  
 Tel/tél. : 1-888-212-1411/Fax/télec. : 1-888-789-0987  
 contact@kangaroo.com / www.kangaroo.com



**Colors / Couleurs**

Post / Poteaux: Blue/Bleu  
 Accent Color / Couleur complémentaire:  
 Yellow/Jaune  
 1 Color panel / Panneaux 1 couleur: Yellow/Jaune  
 2 colors panel / Panneaux 2 couleurs :  
 Green,Tan & Yellow/Vert, beige et jaune  
 Slide / Glissoire: Kentucky Green/Vert kentucky  
 Plastic Climbers / Grimpeur Plastique:  
 NA  
 Cable / Cable : NA  
 Roof / Toît : NA



<b>Kroll-112M2</b>	Min. Protective Surface Required / Surface de protection min. requise : 8.0 m (26'-5") x 11.7 m (38'-4")	Equipment Dimensions / Dimensions de l'équipement : 4.4 m (14'-5") x 8.0 m (26'-4")	Approval date: 17/06/2013 Rev: 00 Initial: TLG
CAN/CSA-Z614-xx xx: Last Edition Published/ Dernière édition publiée	Recommended Ages / Âges recommandés : 18 months to 5 years old / 18 mois à 5 ans	Capacity / Peut accueillir : up to 25 children / Jusqu'à 25 enfants	

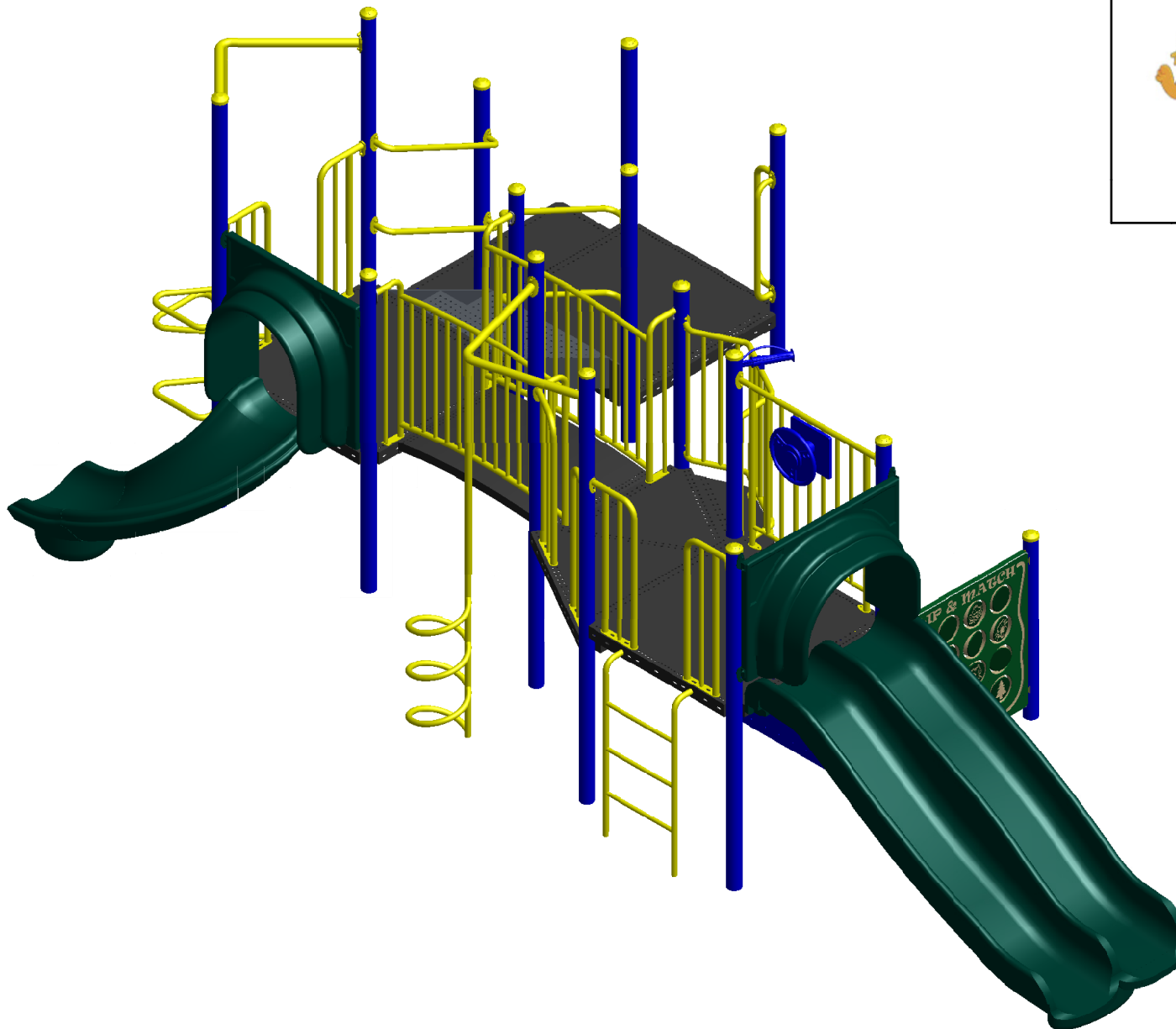

23 ch. Boom Lane, Unit/Unité E  
 Industrial Park/Parc industriel  
 Atholville, New/Nouveau-Brunswick  
 Canada, E3N 4E8  
 Tel/tél. : 1-888-212-1411/Fax/télec. : 1-888-789-0987  
 go@kangaroo.com / www.kangaroo.com

<b>Kroll-112M2</b>	Min. Protective Surface Required / Surface de protection min. requise : 8.0 m (26'-5") x 11.7 m (38'-4")	Equipment Dimensions / Dimensions de l'équipement : 4.4 m (14'-5") x 8.0 m (26'-4")	Approval date: 17/06/2013 Rev: 00 Initial: TLG
CAN/CSA-Z614-xx xx: Last Edition Published/ Dernière édition publiée	Recommended Ages / Âges recommandés : 18 months to 5 years old / 18 mois à 5 ans	Capacity / Peut accueillir : up to 25 children / Jusqu'à 25 enfants	



23 ch. Boom Lane, Unit/Unité E  
 Industrial Park/Parc industriel  
 Atholville, New/Nouveau-Brunswick  
 Canada, E3N 4E8  
 Tel/tél. : 1-888-212-1411/Fax/télec. : 1-888-789-0987  
 go@kangaroo.com / www.kangaroo.com

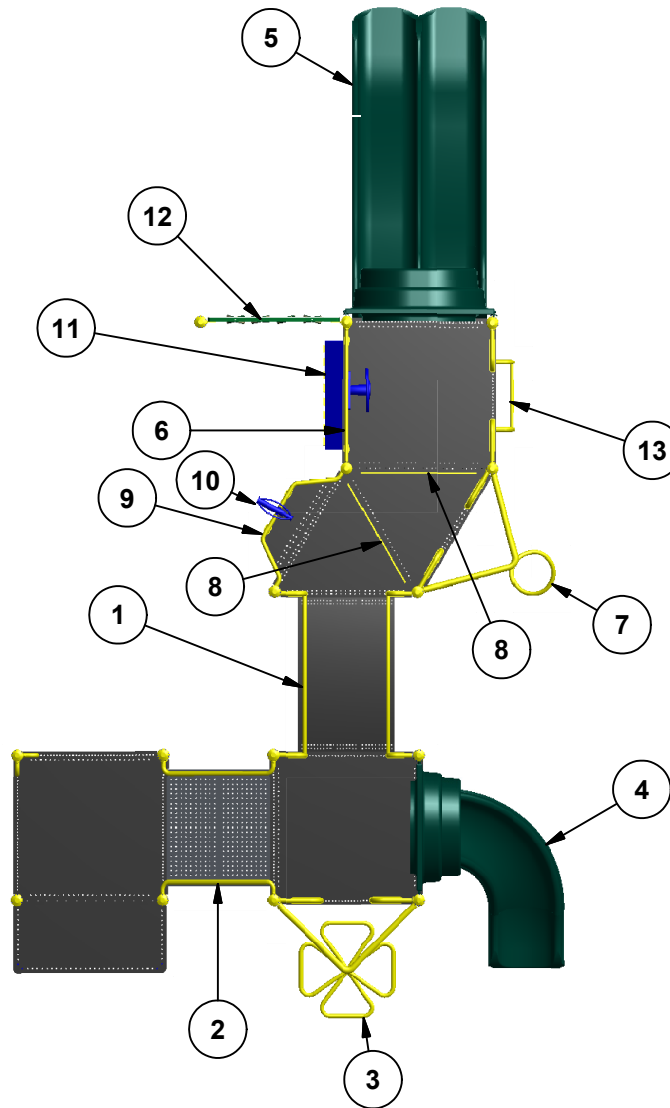

Legend / Légende

ITEM	QTY	Description
1	1	Arch Bridge / Pont en arche
2	1	Transfer Station/Marches accessibles
3	1	Flower Climber / Grimpeur en Fleur
4	1	90° Curved slide 36"/ Glissoire courbée 90°, 36"
5	1	Triple Rail Slide 48" / Glissoire double 48"
6	1	Car Panel / Panneau auto
7	1	Spiral Climber / Grimpeur Spiral
8	2	Risser 6"/Contre-marche 6"
9	1	Balcony Deck / Balcon
10	1	Telescope / Télescope
11	1	Kg Piano Panel / Panneau Kg Piano
12	1	Kg Memory Game / Jeux de mémoire Kg
13	1	Rung Ladder/ Echelle à barreaux

**Kroll-112M2**

Min. Protective Surface Required / Surface de protection min. requise :  
 8.0 m (26'-5") x 11.7 m (38'-4")

Equipment Dimensions / Dimensions de l'équipement :  
 4.4 m (14'-5") x 8.0 m (26'-4")

Approval date: 17/06/2013  
 Rev: 00  
 Initial: TLG

CAN/CSA-Z614-xx  
 xx: Last Edition Published/  
 Dernière édition publiée

Recommended Ages / Âges recommandés :  
 18 months to 5 years old / 18 mois à 5 ans

Capacity / Peut accueillir :  
 up to 25 children / Jusqu'à 25 enfants





Access to All /  
Accessible

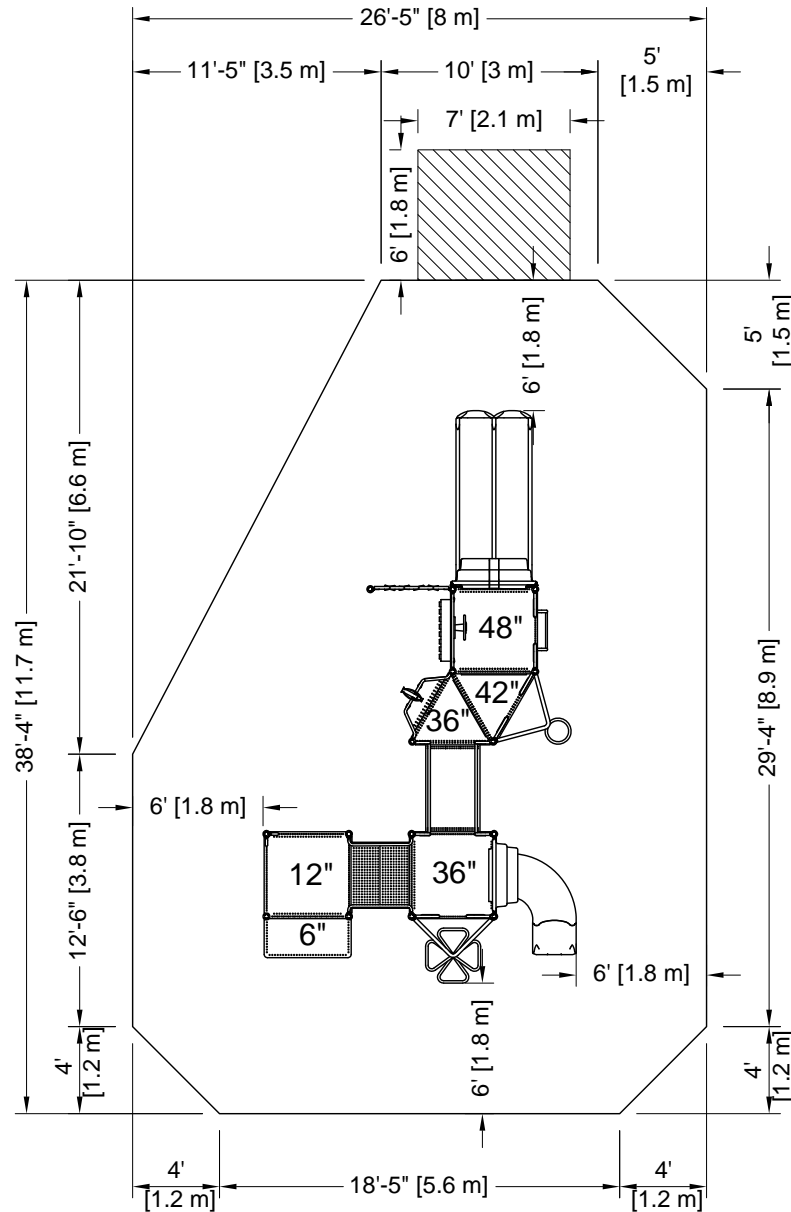

PLATFORM HEIGHTS  
HAUTEURS DE PLATEFORME

6" = 152MM	60" = 1524MM
12" = 305MM	72" = 1829MM
24" = 609MM	84" = 2134MM
36" = 915MM	96" = 2438MM
42" = 1067MM	
48" = 1219MM	



23 ch. Boom Lane, Unit/Unité E, Industrial Park/Parc industriel  
Atholville, New/Nouveau-Brunswick  
Canada, E3N 4E8  
Tel/tél. : 1-888-212-1411 - Fax/télé. : 1-888-789-0987  
contact@kangoroo.com / www.kangoroo.com

**ZONE DE PROTECTION:**

Chaque équipement doit avoir une zone de protection constituée d'une surface sans obstacle qui se prolonge dans toutes les directions à partir du périmètre de l'équipement. Cette zone doit contenir un revêtement de surface (gravillon, sable, etc...) avec une capacité d'amortissement selon les normes CSA-Z614. Sauf avis contraire.

**Zone de protection minimum require:**

8.0 m (26'-5")  
x  
11.7 m (38'-4")

- Aire : 79.81 m ca.  
(859.09 pi. ca.)

**PROTECTIVE SURFACING ZONE:**

Each equipment shall have a protective surfacing zone that consist of obstacle-free surfacing surrounding the equipment. This zone shall contain shock absorbing materi: (pea gravel, sand, etc...) that comply with CSA-Z614. Unless noted otherwise.

**Minimum Protective Surfacing Zone required:**

8.0 m (26'-5")  
x  
11.7 m (38'-4")

- Surface: 79.81 sq. m  
(859.09 sq. ft.)

**MÉTHODES D'INSTALLATION**

1

**DANS LE BÉTON:**

- Quantité de Sonotube de 12" Ø x 12' : 3

Béton :  
- 1.30 m. cu.  
(1.7 vge cu.)

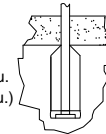

1

**CONCRETE:**

- Quantity of Sonotube of 12" Ø x 12': 3

Concrete:  
- 1.30 cu. m.  
(1.7 cu. yd.)

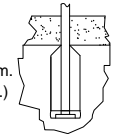

2

**SYSTÈME AUTO-PORTANT:**

Qté charpentes: 9  
Béton :  
- 0 m. cu.  
(0 vge cu.)

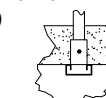

2

**FREE-STANDING SYSTEM**

Frame QTY: 9  
Concrete:  
- 0 cu. m.  
(0 cu. yd.)



**Attention :**

**AIRE DE CIRCULATION LIBRE:**

Aire dégagée d'obstacle qui se prolonge sur au moins 1.8m (70.87") au delà de la zone de protection. Voir dessin pour les détails.



**Warning:**

**NO-ENCROACHMENT ZONE**

Obstacle-free zone extending at least 1.8m (70.87") beyond the protective surfacing zone. See drawing for details.



**Kroll-112M2**

CAN/CSA-Z614-xx  
xx: Last Edition Published /  
Dernière édition publiée

Equipment Dimensions / Dimensions de l'équipement :  
4.4 m (14'-5") x 8.0 m (26'-4")

Capacity / Peut accueillir :  
up to 25 children / Jusqu'à 25 enfants

Recommended Ages / Âges recommandés :  
18 months to 5 years old  
18 mois à 5 ans

Fall Height /  
Hauteur de chute:  
2.28 m (7'-6")

Approval date: 17-06-2013  
Rev: 00  
Initial: TLG

