

23 ch. Boom Lane, Unit/Unité E, Industrial Park/Parc industriel
 Atholville, New-Brunswick, Canada, E3N 4E8
 Tel/tél. : 1-888-212-1411, Fax. : 1-888-789-0987
 contact@kangoroo.com / www.kangoroo.com



Colors / Couleurs

Post / Poteaux: Capri blue/Blue capri

Accent Color / Couleur complémentaire:
 Orange/Orange

1 Color panel / Panneaux 1 couleur: /

2 colors panel / Panneaux 2 couleurs :
 /

Slide / Glissoire: /

Plastic Climbers / Grimpeur Plastique:
 /

Cable / Cable : /

Roof / Toît : /

Kplay-254

Min. Protective Surface Required / Surface de protection min. requise :
 6.7 m (22'-0") x 6.6 m (21'-8")

Equipment Dimensions / Dimensions de l'équipement :
 3.1 m (10'-0") x 2.9 m (9'-8")

Approval date: 25/06/2019

Rev: 00

Initial: AJG

CAN/CSA-Z614-xx
 xx: Last Edition Published/
 Dernière édition publiée

Recommended Ages / Âges recommandés :
 5 to 12 years old / 5 à 12 ans

Capacity / Peut accueillir :
 up to 18 children / Jusqu'à 18 enfants



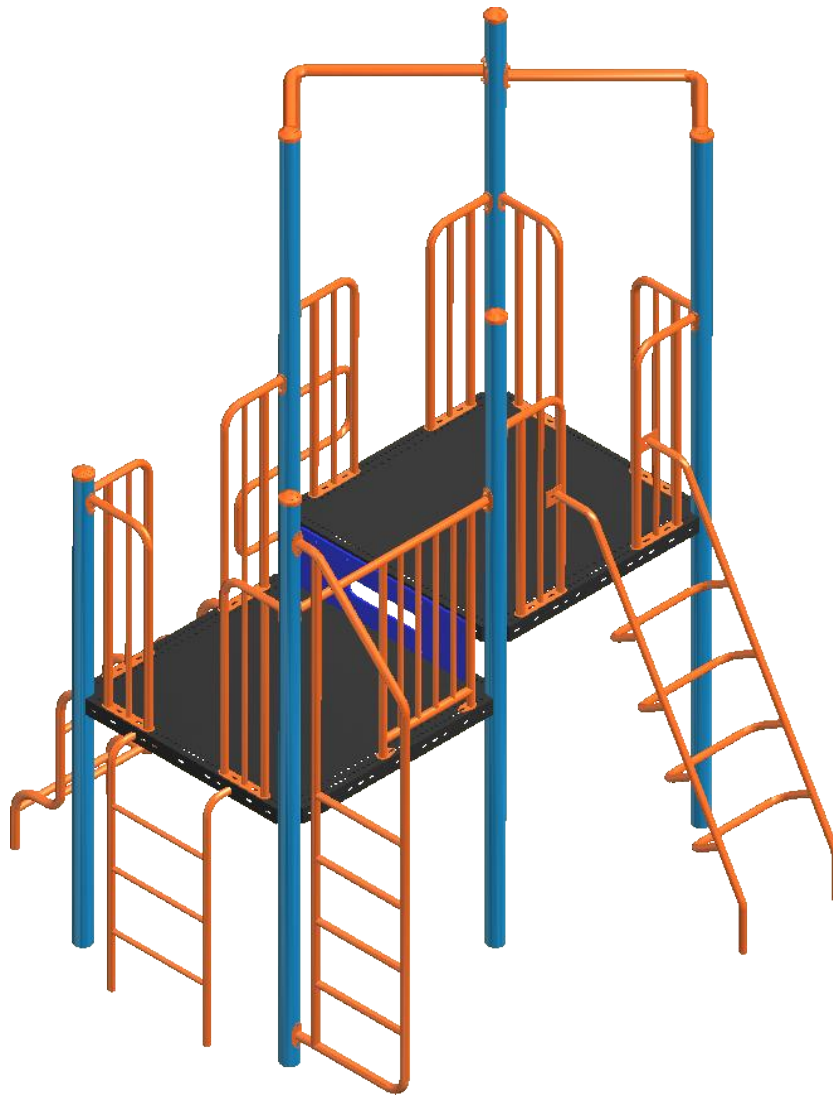

23 ch. Boom Lane, Unit/Unité E
 Industrial Park/Parc industriel
 Atholville, New/Neuveau-Brunswick
 Canada, E3N 4E8
 Tel/tél. : 1-888-212-1411/Fax/télééc. : 1-888-789-0987
 www.kangaroo.com

Kplay-254	Min. Protective Surface Required / Surface de protection min. requise : 6.7 m (22'-0") x 6.6 m (21'-8")	Equipment Dimensions / Dimensions de l'équipement : 3.1 m (10'-0") x 2.9 m (9'-8")	Approval date: 25/06/2019 Rev: 00 Initial: AJG
CAN/CSA-Z614-xx xx: Last Edition Published/ Dernière édition publiée	Recommended Ages / Âges recommandés : 5 to 12 years old / 5 à 12 ans	Capacity / Peut accueillir : up to 18 children / Jusqu'à 18 enfants	



23 ch. Boom Lane, Unit/Unité E
 Industrial Park/Parc industriel
 Atholville, New/Neuveau-Brunswick
 Canada, E3N 4E8
 Tel/tél. : 1-888-212-1411/Fax/télééc. : 1-888-789-0987
 www.kangaroo.com

Legend / Légende

ITEM	QTY	Description	PART # / # PIECE
1	1	Riser 12"/contre-marche 12"	Riser-12
2	1	Ground to Deck Rung Ladder 48"/ Échelle à barreaux sol à plateforme 48"	FS-RG-LA-GTD-48
3	1	Snake pole 60"/ Échelle serpentine 60"	FS-SNK-PL-60
4	1	Inclined Half Loop Climber 48" / Grimpeur à demi-boucles incliné 48"	FS-IHLO-CL-48
5	1	Post Ladder Climber 48"/ Échelle latérale 48"	POST-LAD-48
6	1	Protective barrier / Barrière de protection	R5P
7	1	Bendy Ladder 48"/Échelle Courbée 48"	FS-BD-RG-LA-48
8	1	Fire Pole 60'/ Mât de descente 60"	FS-FR-PL-60

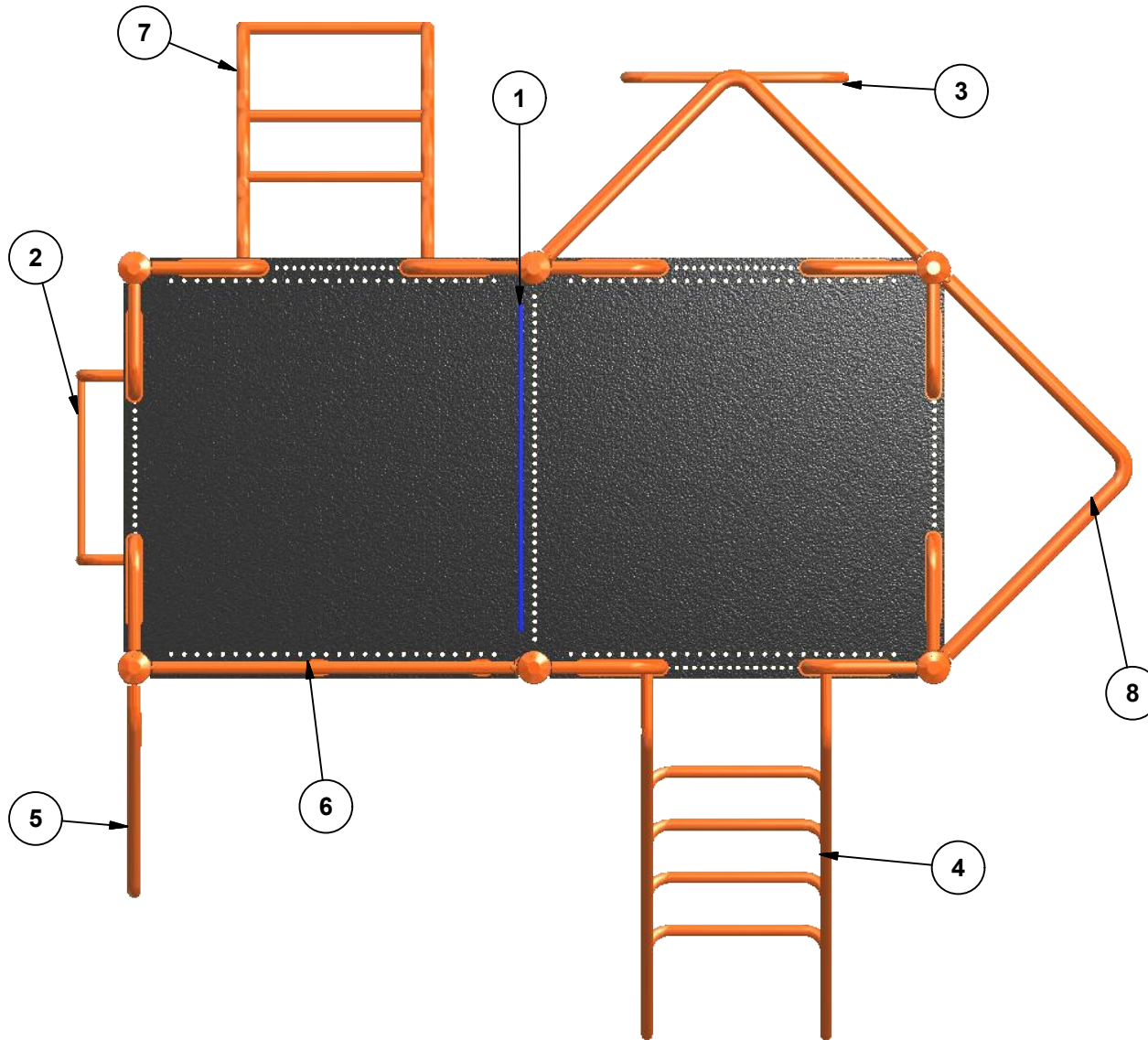

Kplay-254

Min. Protective Surface Required / Surface de protection min. requise :
 6.7 m (22'-0") x 6.6 m (21'-8")

Equipment Dimensions / Dimensions de l'équipement :
 3.1 m (10'-0") x 2.9 m (9'-8")

Approval date: 25/06/2019

Rev: 00

Initial: AJG

CAN/CSA-Z614-xx
 xx: Last Edition Published/
 Dernière édition publiée

Recommended Ages / Âges recommandés :
 5 to 12 years old / 5 à 12 ans

Capacity / Peut accueillir :
 up to 18 children / Jusqu'à 18 enfants



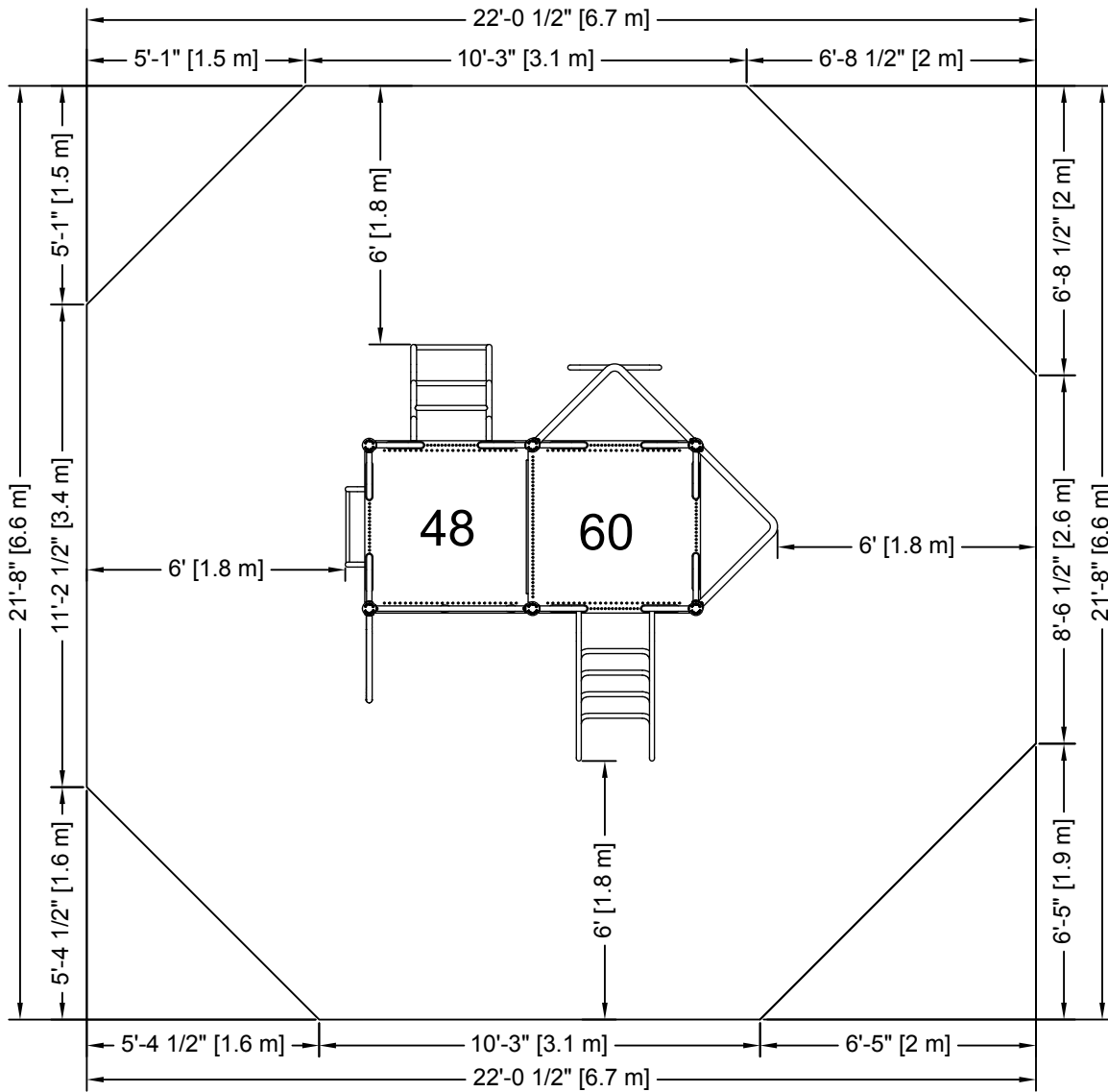

PLATFORM HEIGHTS
 HAUTEURS DE PLATEFORME

12" = 305MM	60" = 1524MM
24" = 609MM	72" = 1829MM
36" = 915MM	84" = 2134MM
48" = 1219MM	96" = 2438MM

ZONE DE PROTECTION:

Chaque équipement doit avoir une zone de protection constituée d'une surface sans obstacle qui se prolonge dans toutes les directions à partir du périmètre de l'équipement. Cette zone doit contenir un revêtement de surface (gravillon, sable, etc...) avec une capacité d'amortissement selon les normes CSA-Z614.

Zone de protection minimum requise:

6.7 m (22'-0")
 x
 6.6 m (21'-8")

- Aire : 37.8 m ca.
 (406.9 pi. ca.)
 - Périmètre : 22.5 m
 (73.7'-")

PROTECTIVE SURFACING ZONE :

Each equipment shall have a protective surfacing zone that consist of obstacle-free surfacing surrounding the equipment. This zone shall contain shock absorbing material (pea gravel, sand, etc...) that comply with CSA-Z614. Unless noted otherwise.

Minimum Protective Surfacing Zone required:

6.7 m (22'-0")
 x
 6.6 m (21'-8")

- Surface: 37.8 sq. m
 (406.9 sq. ft.)
 - Perimeter: 22.5 m
 (73.7'-")

MÉTHODES D'INSTALLATION

1

DANS LE BÉTON:

- Quantité de Sonotube de 12" Ø x 12' :2

Béton :
 - 0.456 m. cu.
 (0.6 vge cu.)

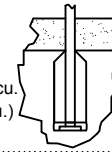

INSTALLATION METHODS

1

CONCRETE:

- Quantity of Sonotube of 12" Ø x 12':2

Concrete:
 - 0.456 cu. m
 (0.6 cu. yd.)

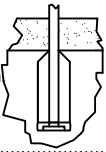

2

SYSTÈME AUTO-PORTANT:

Qté charpentes: 3

Béton :
 - cu.m. m. cu.
 (cu.yd. vge cu.)

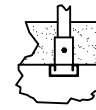

2

FREE-STANDING SYSTEM:

Frame QTY: 3

Concrete:
 - cu.m. cu. m.
 (cu.yd. cu. yd.)



Attention :

AIRE DE CIRCULATION LIBRE:

Aire dégagée d'obstacle qui se prolonge sur au moins 1.8m (70.87") au delà de la zone de protection. Voir dessin pour les détails.



Warning:

NO-ENCROACHMENT ZONE :

Obstacle-free zone extending at least 1.8m (70.87") beyond the protective surfacing zone. See drawing for details.



####

Equipment Dimensions / Dimensions de l'équipement :
 3.1 m (10'-0") x 9.8 m (2.9'-")

Capacity / Peut accueillir :
 up to 18 children / Jusqu'à 18 enfants

Recommended Ages / Âges recommandés :
 5 to 12 years old
 5 à 12 ans

Fall Height /
 Hauteur de chute:
 2.6 m (8'-5")

Approval date: 25/06/2019
 Rev: 00
 Initial: AJG

