

23 ch. Boom Lane, Unit/Unité E
 Industrial Park/Parc industriel
 Atholville, New/Nouveau-Brunswick
 Canada, E3N 4E8
 Tel/tél. : 1-888-212-1411/Fax/télec. : 1-888-789-0987
 go@kangoroo.com / www.kangoroo.com

Kplay-153M2	Min. Protective Surface Required / Surface de protection min. requise : 13 m (42'-8") x 10.2 m (33'-5")	Equipment Dimensions / Dimensions de l'équipement : 9.3 m (30'-8") x 6.5 m (21'-5")	Approval date: 2011-08-05 Rev: 00 Initial: TB
CAN/CSA-Z614-xx xx: Last Edition Published/ Dernière édition publiée	Recommended Ages / Âges recommandés : 5 to 12 years old / 5 à 12 ans	Capacity / Peut accueillir : up to 35 children / Jusqu'à 35 enfants	



23 ch. Boom Lane, Unit/Unité E
 Industrial Park/Parc industriel
 Atholville, New/Nouveau-Brunswick
 Canada, E3N 4E8
 Tel/tél. : 1-888-212-1411/Fax/télec. : 1-888-789-0987
 go@kangoroo.com / www.kangoroo.com

PARTS LIST

ITEM	QTY	PART NUMBER
1	1	Round Monkey Bars / Échelle horizontale en rond
2	1	Suspended Ladder / Échelle suspendue
3	1	Floating stones / Obstacles flottants
4	1	Track / Glisseur sur rail
5	1	Bean Climber / Échelle haricots
6	1	Loop Climber 72" / Échelle à boucles 72"
7	1	Spiral Climber / Grimpeur spiral
8	1	Snake Pole / Échelle serpentine
9	1	Bench Panel Below/ Panneau banc en dessous
10	1	Wavy Double Wall Slide 72" / Glissoire simple en vague 72"
11	1	Wishbone Bridge / Traverse de sillon
12	1	Ladder Panel 24"/ Panneau échelle 24"

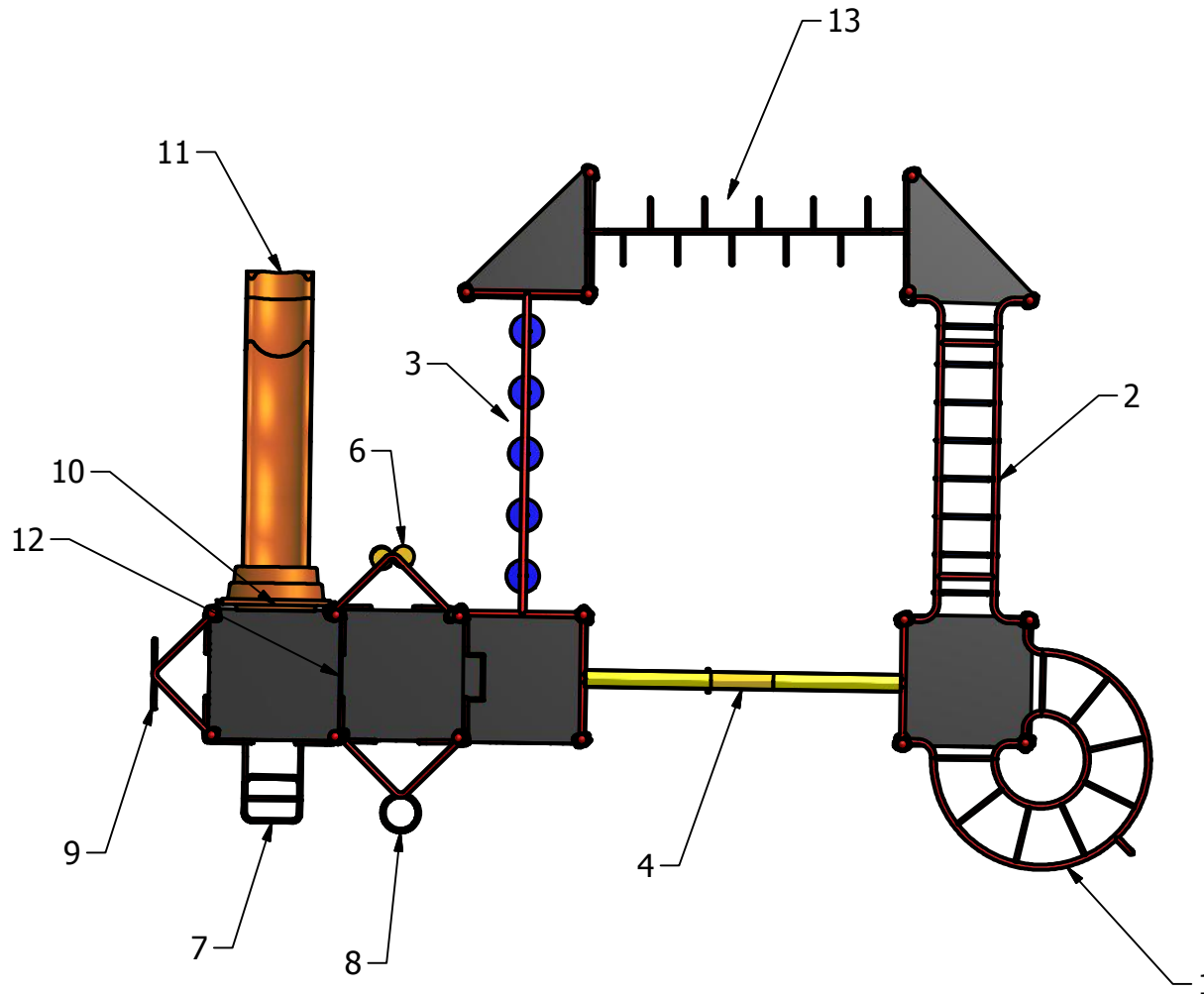

Kplay-153M2	Min. Protective Surface Required / Surface de protection min. requise : 13 m (42'-8") x 10.2 m (33'-5")	Equipment Dimensions / Dimensions de l'équipement : 9.3 m (30'-8") x 6.5 m (21'-5")	Approval date: 2011-08-05 Rev: 00 Initial: TB
CAN/CSA-Z614-xx xx: Last Edition Published/ Dernière édition publiée	Recommended Ages / Âges recommandés : 5 to 12 years old / 5 à 12 ans	Capacity / Peut accueillir : up to 35 children / Jusqu'à 35 enfants	



23 ch. Boom Lane, Unit/Unité E
 Industrial Park/Parc industriel
 Atholville, New/Nouveau-Brunswick
 Canada, E3N 4E8
 Tel/tél. : 1-888-212-1411/Fax/télec. : 1-888-789-0987
 go@kangaroo.com / www.kangaroo.com

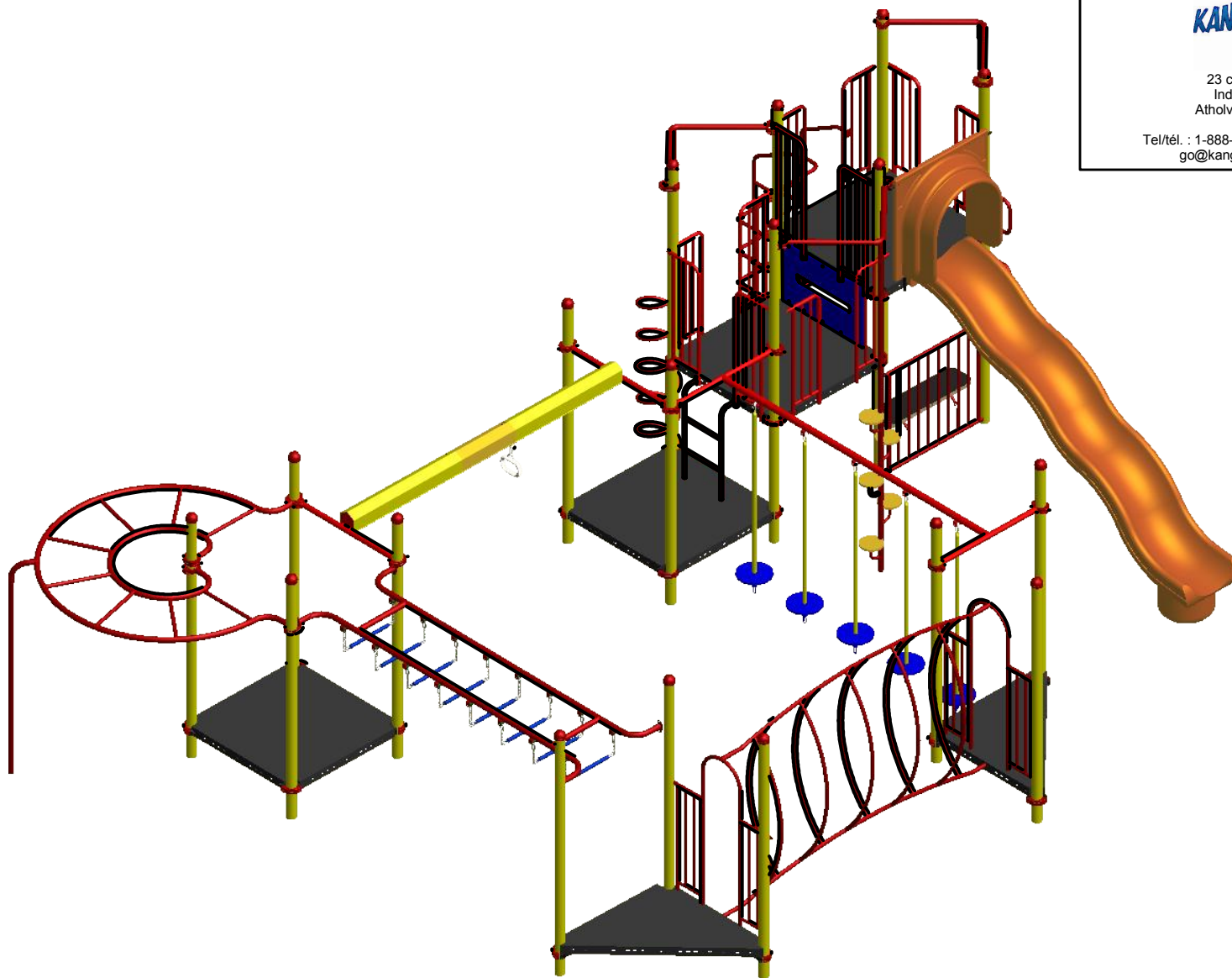

Kplay-153M2	Min. Protective Surface Required / Surface de protection min. requise : 13 m (42'-8") x 10.2 m (33'-5")	Equipment Dimensions / Dimensions de l'équipement : 9.3 m (30'-8") x 6.5 m (21'-5")	Approval date: 2011-08-05 Rev: 00
CAN/CSA-Z614-xx xx: Last Edition Published/ Dernière édition publiée	Recommended Ages / Âges recommandés : 5 to 12 years old / 5 à 12 ans	Capacity / Peut accueillir : up to 35 children / Jusqu'à 35 enfants	Initial: TB 



23 ch. Boom Lane, Unit/Unité E
 Industrial Park/Parc industriel
 Atholville, New/Nouveau-Brunswick
 Canada, E3N 4E8
 Tel/tél. : 1-888-212-1411/Fax/télec. : 1-888-789-0987
 go@kangoroo.com / www.kangoroo.com

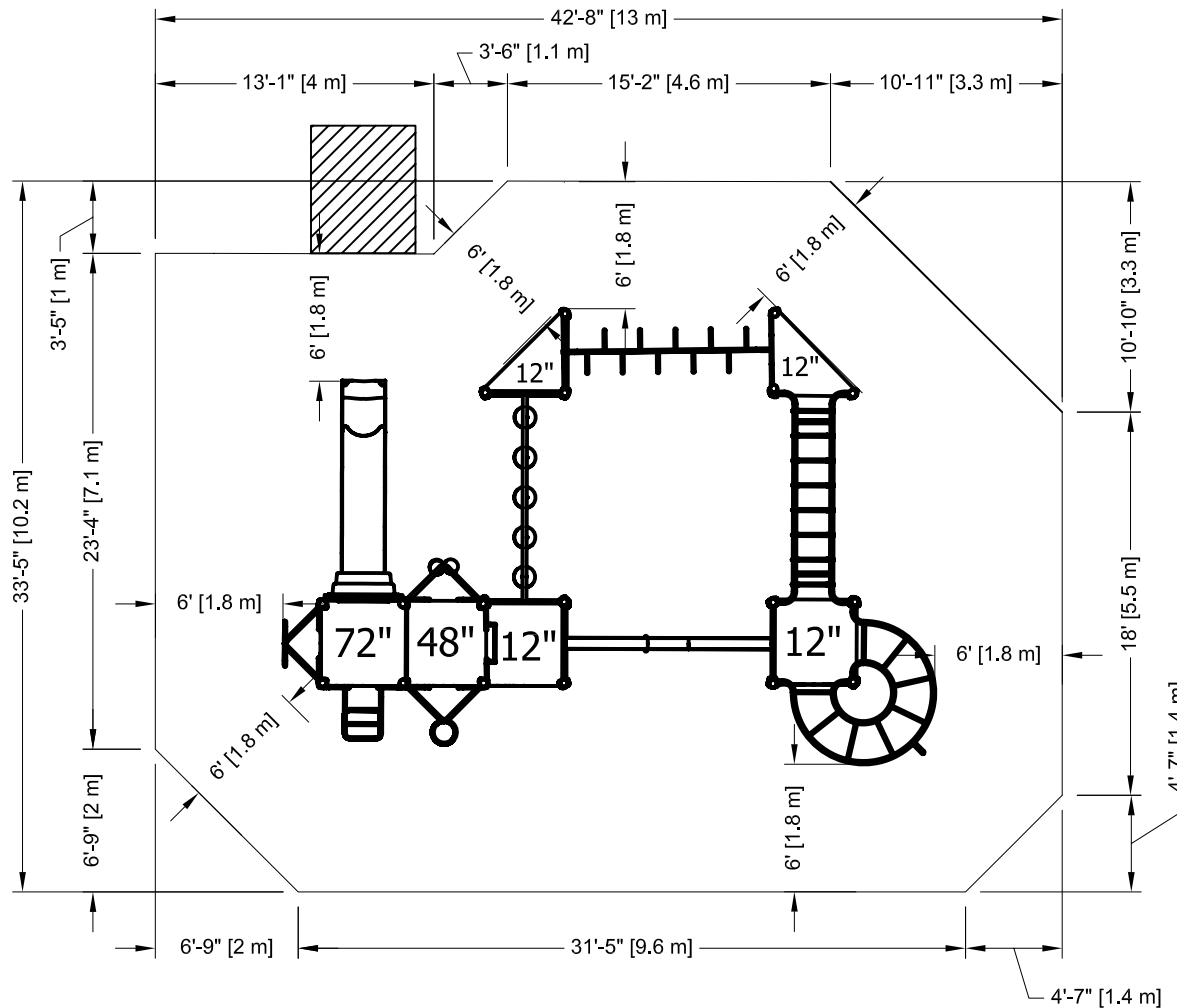

<p>Légende :</p> <p>Zone de protection minimum</p> <p>Aire de circulation libre</p> <p>Autre</p>	<p>Legend:</p> <p>Minimum Protective Surfacing Zone</p> <p>No-Encroachment Zone</p> <p>Other</p>
<p>Zone de protection minimum requise:</p> <p>- Aire : 119.28 m ca. (1283.92 pi. ca.)</p>	<p>Minimum Protective Surfacing Zone required:</p> <p>- Surface: 119.28 sq. m (1283.92 sq. ft.)</p>
<p>SI INSTALLATION DANS LE BÉTON</p> <p>Sonotube de 12" Ø x 12" :</p> <p>- Quantité : 5</p> <p>Béton :</p> <p>- 1.8 vge cu.</p>	<p>IF INSTALLED IN CONCRETE</p> <p>Sonotube of 12" Ø x 12" :</p> <p>- Quantity: 5</p> <p>Concrete:</p> <p>- 1.8 cu. yd.</p>
<p>Attention :</p> <p>ZONE DE PROTECTION:</p> <p>Chaque équipement doit avoir une zone de protection constituée d'une surface sans obstacle qui se prolonge dans toutes les directions à partir du périmètre de l'équipement. Cette zone doit contenir un revêtement de surface (gravillon, sable, etc...) avec une capacité d'amortissement selon les normes CSA-Z614. Sauf avis contraire. Voir dessin pour les dimensions de la zone.</p> <p>AIRE DE CIRCULATION LIBRE:</p> <p>Aire dégagée d'obstacle qui se prolonge sur au moins 1.8m (70.87") au delà de la zone de protection. Voir dessin pour les détails.</p>	<p>Warning:</p> <p>PROTECTIVE SURFACING ZONE : Each equipment shall have a protective surfacing zone that consist of obstacle-free surfacing surrounding the equipment. This zone shall contain shock absorbing material (pea gravel, sand, etc...) that comply with CSA-Z614. Unless noted otherwise. See drawing for dimensions of zone.</p> <p>NO-ENCROACHMENT ZONE : Obstacle-free zone extending at least 1.8m (70.87") beyond the protectice surfacing zone. See drawing for details.</p>

<p>Kplay-153M2</p> <p>CAN/CSA-Z614-xx xx: Last Edition Published / Dernière édition publiée</p>	<p>Min. Protective Surfacing Zone Required / Zone de protection min. requise : 13 m (42'-8") x 10.2 m (33'-5")</p> <p>Recommended Ages / Âges recommandés : 5 to 12 years old / 5 a 12 ans</p>	<p>Equipment Dimensions / Dimensions de l'équipement : 9.3 m (30'-8") x 6.5 m (21'-5")</p> <p>Capacity / Peut accueillir : up to 35 children / Jusqu'à 35 enfants</p>	<p>Approval date: 08-05-2011 Rev: 00 Initial: TB</p>
---	--	---	--