



23 ch. Boom Lane, Unit/Unité E
 Industrial Park/Parc industriel
 Atholville, New/Nouveau-Brunswick
 Canada, E3N 4E8
 Tel/tél. : 1-888-212-1411/Fax/télec. : 1-888-789-0987
 contact@kangoroo.com / www.kangoroo.com

Colors / Couleurs

Post / Poteaux: Blue and Yellow/bleu et jaune
 Accent Color / Couleur complémentaire:
 Blue and Yellow/bleu et jaune
 1 Color panel / Panneaux 1 couleur: /
 2 colors panel / Panneaux 2 couleurs :
 Blue and Yellow/bleu et jaune
 Slide / Glissoire: Blue and Purple/bleu et violet
 Plastic Climbers / Grimpeur Plastique:
 Blue and Yellow/bleu et jaune
 Cable / Cable : /
 Roof / Toit : Blue/bleu



Kplay-135_M3

Min. Protective Surface Required / Surface de protection min. requise :
 11.4 m (37'-3") x 13.5 m (44'-5")

Equipment Dimensions / Dimensions de l'équipement :
 9.9 m (32'-5") x 7.7 m (25'-3")

Approval date: 24/03/2016
 Rev: 00
 Initial: AMR

CAN/CSA-Z614-xx
 xx: Last Edition Published/
 Dernière édition publiée

Recommended Ages / Âges recommandés :
 5 to 12 years old / 5 à 12 ans

Capacity / Peut accueillir :
 up to 40 children / Jusqu'à 40 enfants





23 ch. Boom Lane, Unit/Unité E
 Industrial Park/Parc industriel
 Atholville, New/Nouveau-Brunswick
 Canada, E3N 4E8
 Tel/tél. : 1-888-212-1411/Fax/télééc. : 1-888-789-0987
 www.kangaroo.com

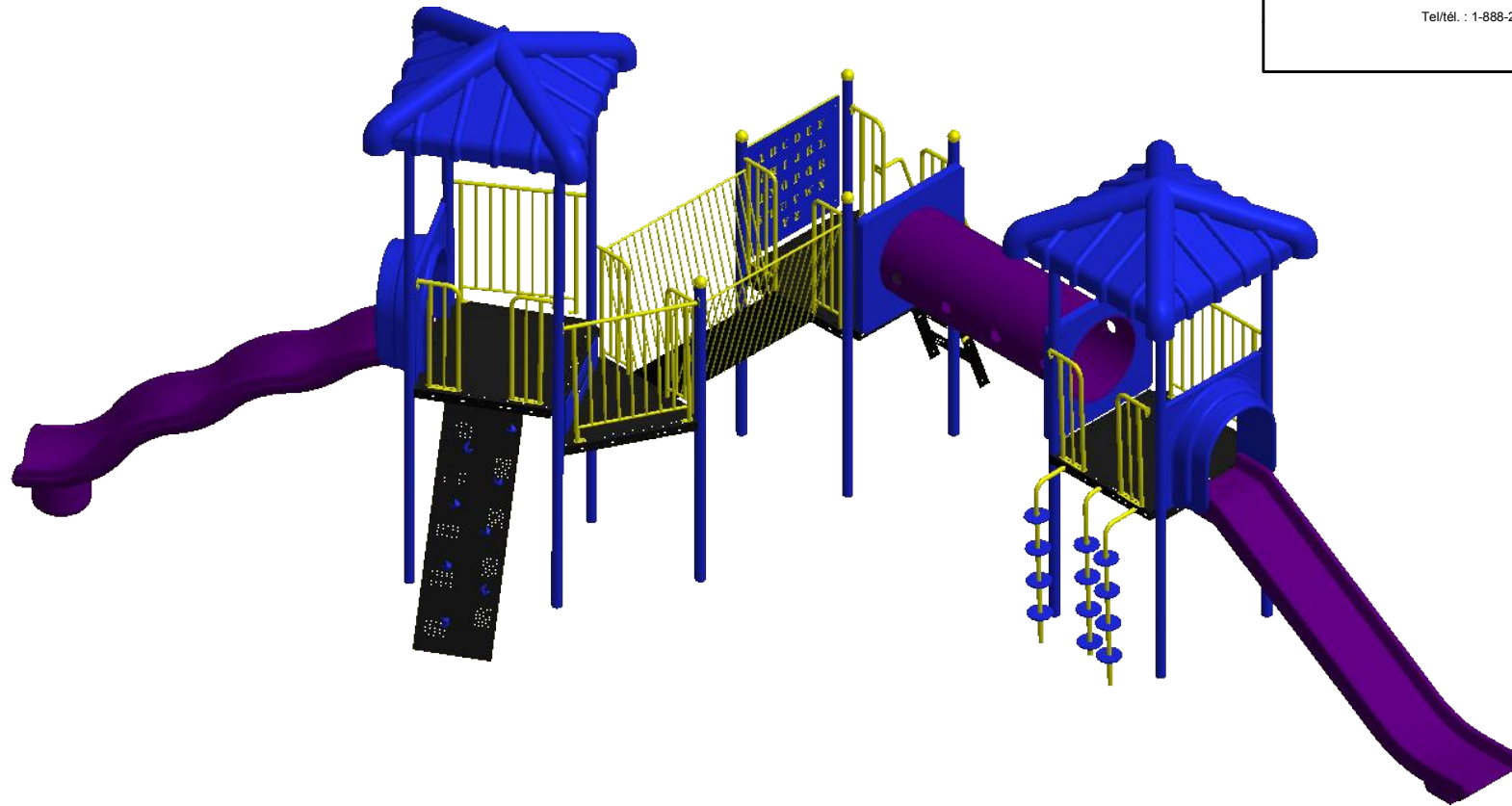

| | | | |
|--|--|--|---|
| Kplay-135_M3 | Min. Protective Surface Required / Surface de protection min. requise : 11.4 m (37'-3") x 13.5 m (44'-5") | Equipment Dimensions / Dimensions de l'équipement : 9.9 m (32'-5") x 7.7 m (25'-3") | Approval date: 24/03/2016 Rev: 00 Initial: AMR |
| CAN/CSA-Z614-xx xx: Last Edition Published/ Dernière édition publiée | Recommended Ages / Âges recommandés : 5 to 12 years old / 5 à 12 ans | Capacity / Peut accueillir : up to 40 children / Jusqu'à 40 enfants |  |



23 ch. Boom Lane, Unit/Unité E
 Industrial Park/Parc industriel
 Atholville, New/Nouveau-Brunswick
 Canada, E3N 4E8
 Tel/tél. : 1-888-212-1411/Fax/télééc. : 1-888-789-0987
 www.kangaroo.com

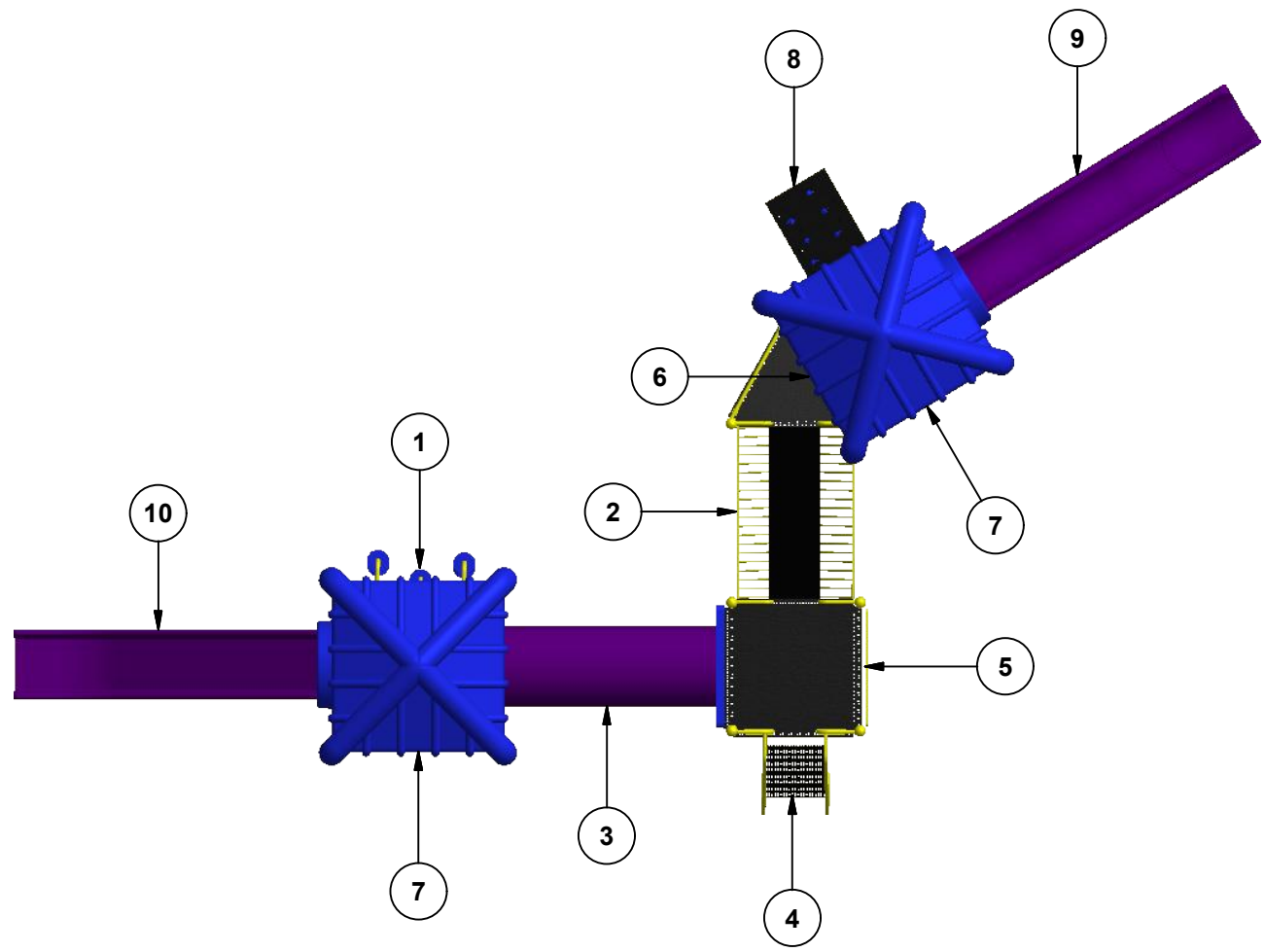

Legend / Légende

| ITEM | QTY | Description | PART # / # PIECE |
|------|-----|--|------------------|
| 1 | 1 | Pommel climber 60"/grimpeur à pommeaux 60" | POM-CL-60 |
| 2 | 1 | Cat Walk 60"/pont "le cat walk" 60"L | BRI-CATW |
| 3 | 1 | Tunnel 30"Ø x 7"/tunnel 30"Ø x 7' | A-502D |
| 4 | 1 | Ladder Climber/grimpeur à palier | CL-STRW-60" |
| 5 | 1 | KG Alphabet Panel/panneau alphabet KG | KG-Alpha |
| 6 | 1 | Riser 12"/contre-marche 12" | RISER-12 |
| 7 | 2 | Double Wall Pyramid Roof/toit pyramide a double paroi | PYRA-RF |
| 8 | 1 | Alpine Wall 72"/mur alpin 72" | FS-AC-72 |
| 9 | 1 | Wavy Double Wall Slide 72"/glissoire simple en vague 72" | SLD-1_WV-SP-72" |
| 10 | 1 | Double Wall Slide 60"/glissoire simple 60" | SLD-1-001-60" |

| | | | |
|--|--|--|---|
| Kplay-135_M3 | Min. Protective Surface Required / Surface de protection min. requise : 11.4 m (37'-3") x 13.5 m (44'-5") | Equipment Dimensions / Dimensions de l'équipement : 9.9 m (32'-5") x 7.7 m (25'-3") | Approval date: 24/03/2016 Rev: 00 Initial: AMR |
| CAN/CSA-Z614-xx xx: Last Edition Published/ Dernière édition publiée | Recommended Ages / Âges recommandés : 5 to 12 years old / 5 à 12 ans | Capacity / Peut accueillir : up to 40 children / Jusqu'à 40 enfants |  |



23 ch. Boom Lane, Unit/Unité E
 Industrial Park/Parc industriel
 Atholville, New/Nouveau-Brunswick
 Canada, E3N 4E8
 Tel/tél. : 1-888-212-1411/Fax/télééc. : 1-888-789-0987
 go@kangoroo.com / www.kangoroo.com

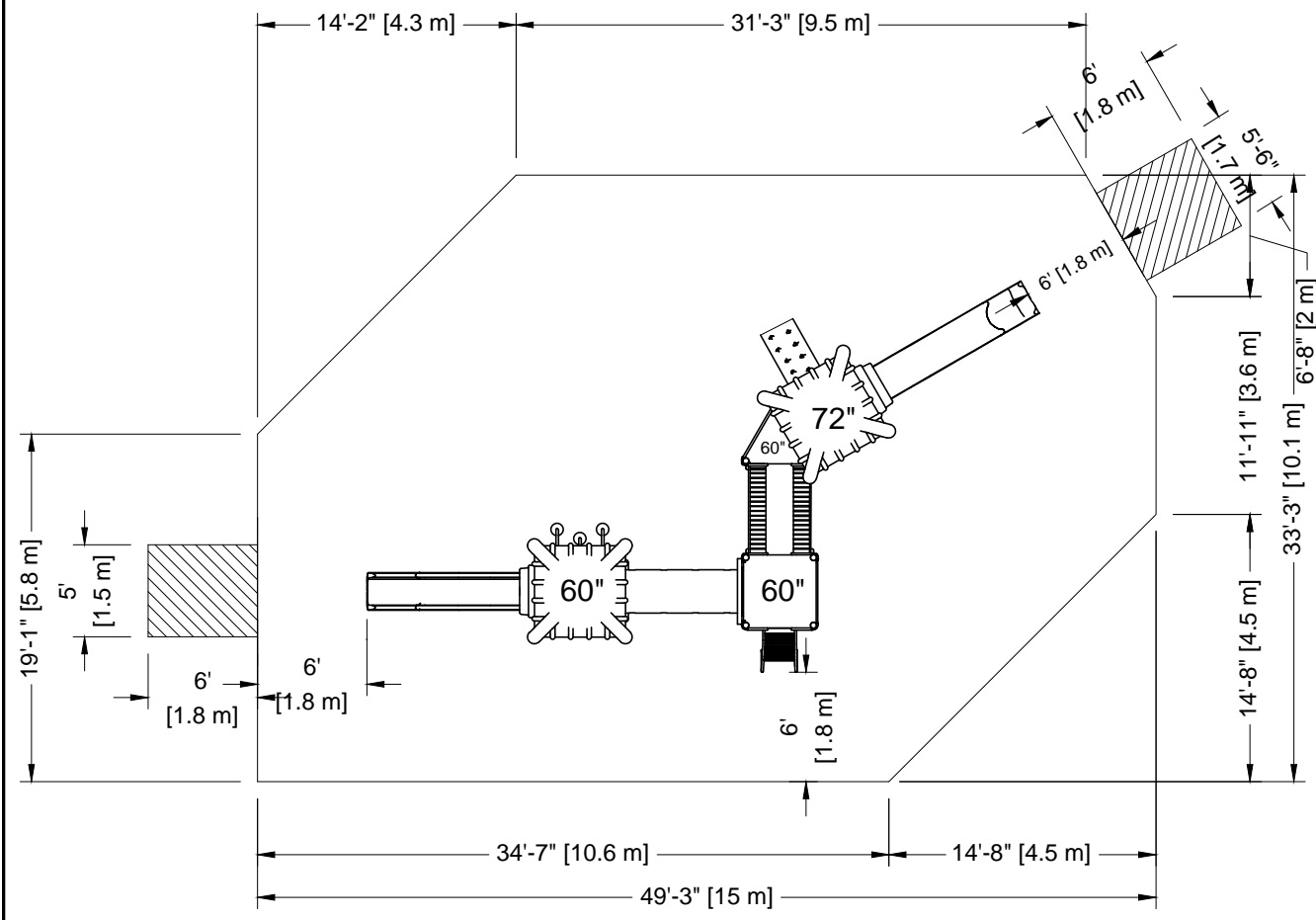



PLATFORM HEIGHTS
 HAUTEURS DE PLATEFORME

| | |
|--------------|--------------|
| 12" = 305MM | 60" = 1524MM |
| 24" = 609MM | 72" = 1829MM |
| 36" = 915MM | 84" = 2134MM |
| 48" = 1219MM | 96" = 2438MM |

Légende :

Zone de protection minimum



Aire de circulation libre

Autre

Legend:

Minimum Protective Surfacing Zone

No-Encroachment Zone

Other

Zone de protection minimum requise:
 - Aire : 138.39 m ca.
 (1489.64 pi. ca.)

Minimum Protective Surfacing Zone required:
 - Surface: 138.39 sq. m
 (1489.64 sq. ft.)

SI INSTALLATION DANS LE BÉTON
Sonotube de 12" Ø x 12' :
 - Quantité : 4
Béton :
 - 2.0 vge cu.

IF INSTALLED IN CONCRETE
Sonotube of 12" Ø x 12' :
 - Quantity: 4
Concrete:
 - 2.0 cu. yd.

Attention :
ZONE DE PROTECTION:
 Chaque équipement doit avoir une zone de protection constituée d'une surface sans obstacle qui se prolonge dans toutes les directions à partir du périmètre de l'équipement. Cette zone doit contenir un revêtement de surface (gravillon, sable, etc...) avec une capacité d'amortissement selon les normes CSA-Z614. Sauf avis contraire. Voir dessin pour les dimensions de la zone.

Warning:
PROTECTIVE SURFACING ZONE : Each equipment shall have a protective surfacing zone that consist of obstacle-free surfacing surrounding the equipment. This zone shall contain shock absorbing material (pea gravel, sand, etc...) that comply with CSA-Z614. Unless noted otherwise. See drawing for dimensions of zone.
NO-ENCROACHMENT ZONE : Obstacle-free zone extending at least 1.8m (70.87") beyond the protective surfacing zone. See drawing for details.

AIRE DE CIRCULATION LIBRE:
 Aire dégagée d'obstacle qui se prolonge sur au moins 1.8m (70.87") au delà de la zone de protection. Voir dessin pour les détails.

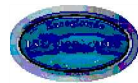
| | | | |
|---|--|--|--|
| Kplay-135_M3 | Min. Protective Surfacing Zone Required / Zone de protection min. requise : 11.4 m (37'-3") x 13.5 m (44'-5") | Equipment Dimensions / Dimensions de l'équipement : 9.9 m (32'-5") x 7.7 m (25'-3") | Approval date: 24-03-2016 Rev: 00 Initial: AMR  |
| CAN/CSA-Z614-xx xx: Last Edition Published / Dernière édition publiée | Recommended Ages / Âges recommandés : 5 to 12 years old / 5 à 12 ans | Capacity / Peut accueillir : up to 40 children / Jusqu'à 40 enfants | |