

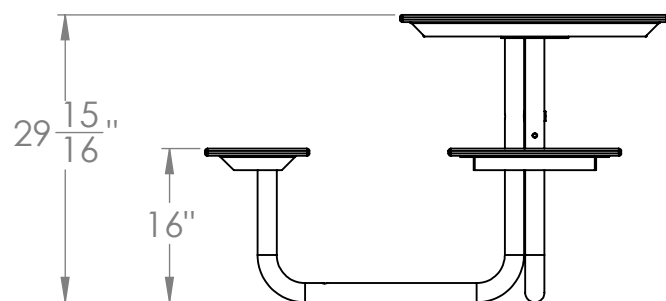

23 ch. Boom Lane, Unit/Unité E Industrial
Park/Parc industriel Atholville, New/Nouveau-
Brunswick Canada, E3N 4E8
Tel/tél. : 1-888-212-1411/Fax/téloc. : 1-888-
789-0987 www.kangoroo.com

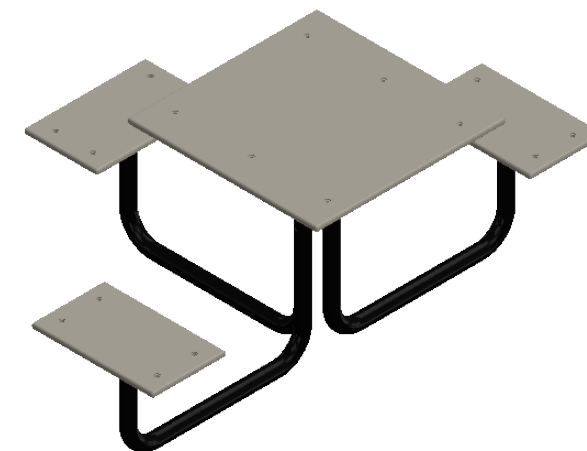
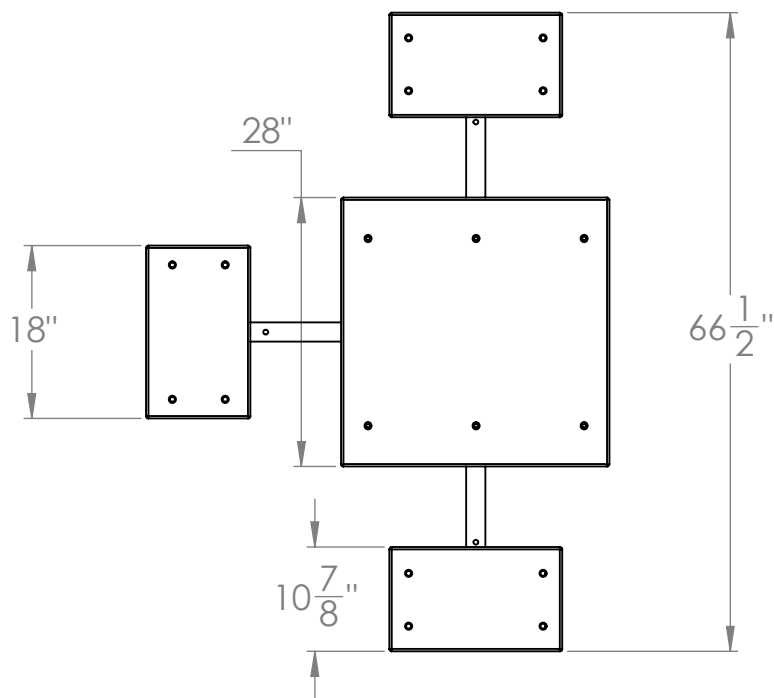

kpark-01AM2

Equipment Dimensions / Dimensions de l'équipement :
66 5/8in x 29 15/16in

Approval date: 15-01-21

Rev: 00

Initial: AK