

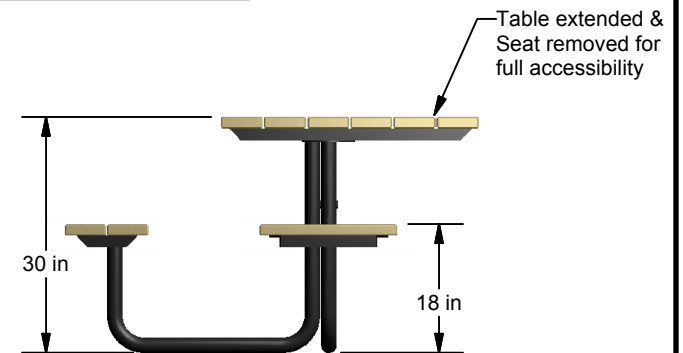

TERRAINS DE JEUX
KANGOROO
 PLAYGROUNDS
 23 ch. Boom Lane, Unit/Unité E
 Industrial Park/Parc industriel
 Atholville, New/Novveau-Brunswick
 Canada, E3N 4E6
 Tel/tél. : 1-888-212-1411/Fax/télééc. : 1-888-789-0987
 www.kangoroo.com

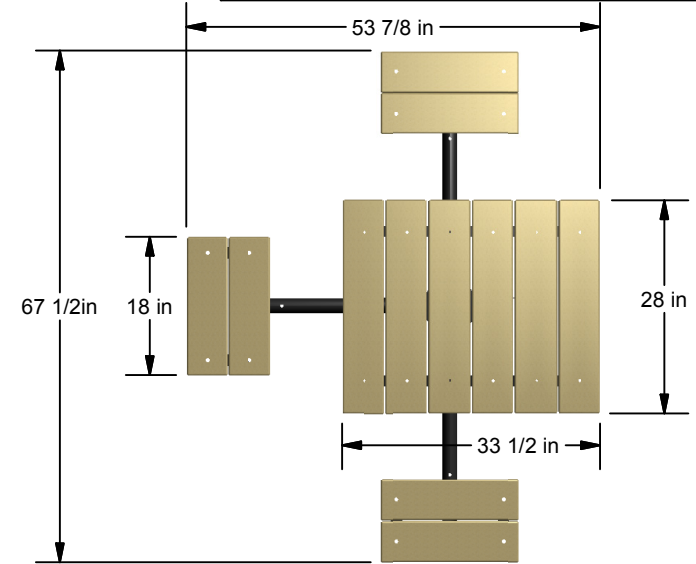

ALL STEEL
 -ALLIED PRE-GALVINISED
 COVERED WITH A
 POLYESTER POWDER PAINT.
TOUT ACIER
 PRÉ-GALVANISÉ "ALLIÉD"
 COUVERT D'UNE PEINTURE DE
 POUDRE DE POLYESTER.

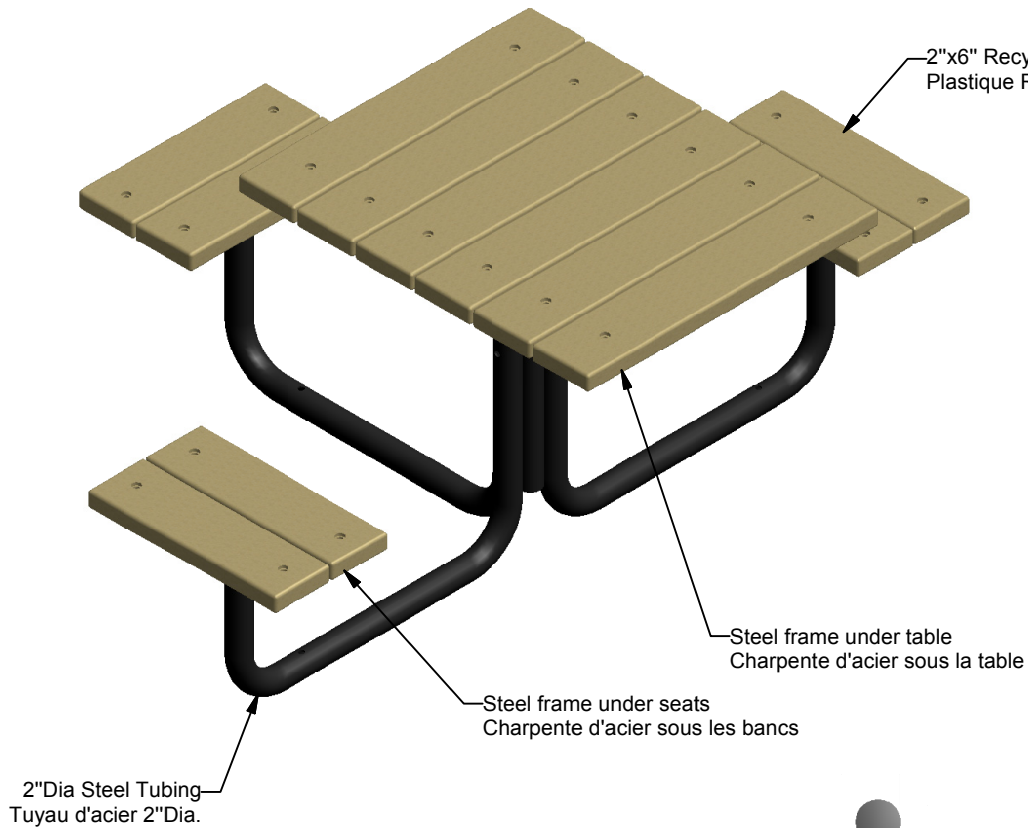

Access to All /
Accessible

Kpark-01A-M1

Sonotubes & Concrete Recommendations :
 Recommendations de sonotubes et béton :

KAN-PARK

Sonotube of 12"Ø x 24"L / Sonotube de 12"Ø x 24"L :1
 Concrete (cu. yd.) / Ciment (vge cu.) : 0.3

Equipment Dimensions / Dimensions de l'équipement :
 1.71 m (5'-7 1/2") x 1.71 m (5'-7 1/2") x 0.76 m (2'-6")H

Capacity / Capacité :
 4

Approval date: 15/12/2009
 Rev: 00

Initial: TLG

