

23 ch. Boom Lane, Unit/Unité E, Industrial Park/Parc industriel  
 Atholville, New-Brunswick, Canada, E3N 4E8  
 Tel/tél. : 1-888-212-1411, Fax. : 1-888-789-0987  
 contact@kangaroo.com / www.kangaroo.com



### Colors / Couleurs

Post / Poteaux: Cyan/Cyan

Accent Color / Couleur complémentaire:  
 Orange/Orange

1 Color panel / Panneaux 1 couleur: Blue/Bleu

2 colors panel / Panneaux 2 couleurs :  
 NA

Slide / Glissoire: Cyan/Cyan

Plastic Climbers / Grimpeur Plastique:  
 NA

Cable / Cable : NA

Roof / Toît : NA

### Kkids-159

CAN/CSA-Z614-xx  
 xx: Last Edition Published/  
 Dernière édition publiée

Min. Protective Surface Required / Surface de protection min. requise :  
 8.8 m (28'-10") x 6.6 m (21'-8")

Recommended Ages / Âges recommandés :  
 18 months to 12 years old / 18 mois à 12 ans

Equipment Dimensions / Dimensions de l'équipement :  
 5.1 m (16'-10") x 2.9 m (9'-8")

Capacity / Peut accueillir :  
 up to 25 children / Jusqu'à 25 enfants

Approval date: 19/06/2019  
 Rev: 00  
 Initial: TLG





23 ch. Boom Lane, Unit/Unité E  
 Industrial Park/Parc industriel  
 Atholville, New/Novveau-Brunswick  
 Canada, E3N 4E8  
 Tel/tél. : 1-888-212-1411/Fax/télé. : 1-888-789-0987  
 www.kangaroo.com

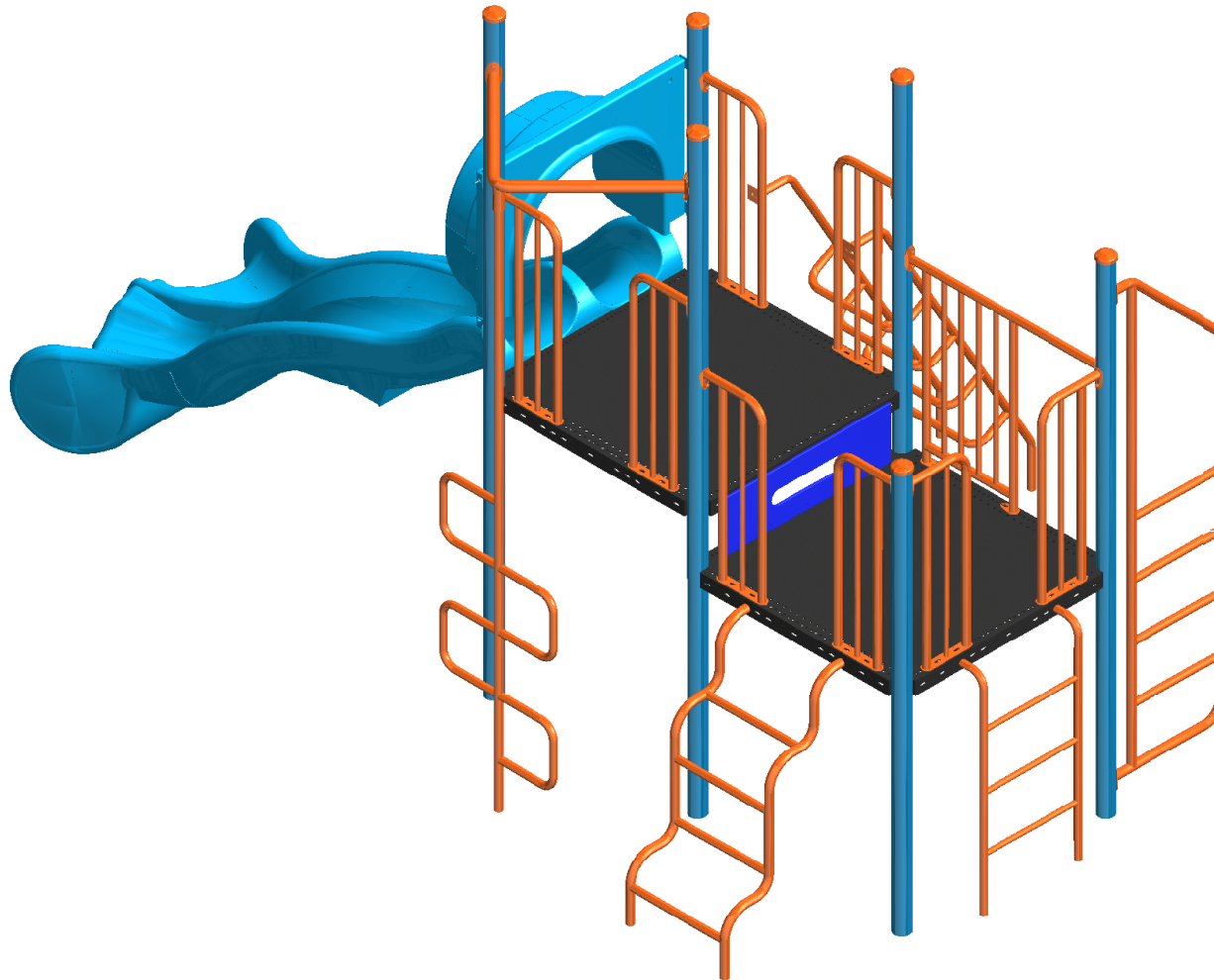

<b>Kkids-159</b>	Min. Protective Surface Required / Surface de protection min. requise : 8.8 m (28'-10") x 6.6 m (21'-8")	Equipment Dimensions / Dimensions de l'équipement : 5.1 m (16'-10") x 2.9 m (9'-8")	Approval date: 19/06/2019 Rev: 00 Initial: TLG
CAN/CSA-Z614-xx xx: Last Edition Published/ Dernière édition publiée	Recommended Ages / Âges recommandés : 18 months to 12 years old / 18 mois à 12 ans	Capacity / Peut accueillir : up to 25 children / Jusqu'à 25 enfants	



23 ch. Boom Lane, Unit/Unité E  
 Industrial Park/Parc industriel  
 Atholville, New/Nouveau-Brunswick  
 Canada, E3N 4E8  
 Tel/tél. : 1-888-212-1411/Fax/télééc. : 1-888-789-0987  
 www.kangoroo.com

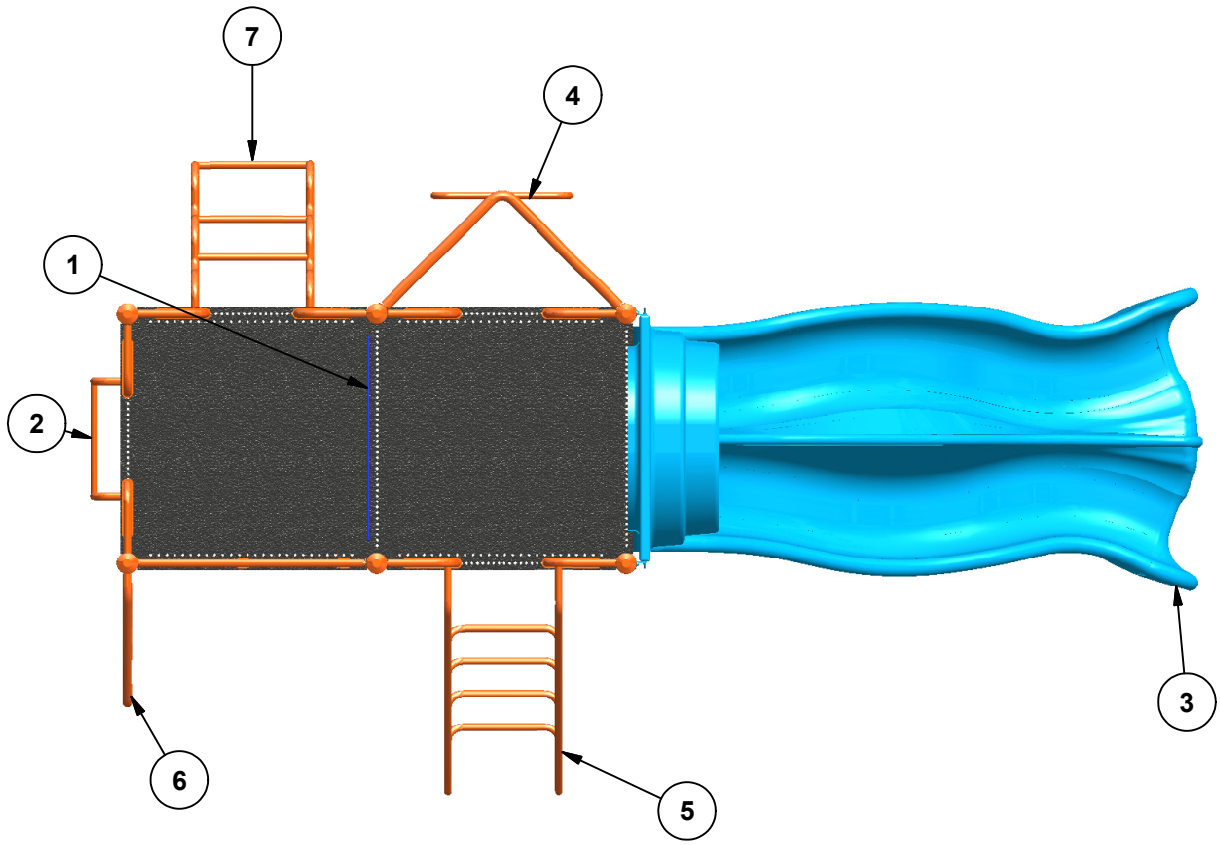

Legend / Légende

ITEM	QTY	Description	PART # / # PIECE
1	1	Riser 12"/contre-marche 12"	Riser-12
2	1	Ground to Deck Rung Ladder 48"/ Échelle à barreaux sol à plateforme 48"	FS-RG-LA-GTD-48
3	1	Duo-Slide 60"/Glissoire double "Duo-Slide" 60"	FS-5TRS
4	1	Snake pole 60"/ Échelle serpentine 60"	FS-SNK-PL-60
5	1	Inclined Half Loop Climber 48"/ Grimpeur à demi-boucles incliné 48"	FS-IHLO-CL-48
6	1	Post Ladder Climber 48"/ Échelle latérale 48"	POST-LAD-48
7	1	Bendy Ladder 48"/Échelle Courbée 48"	FS-BD-RG-LA-48

<b>Kkids-159</b>  CAN/CSA-Z614-xx xx: Last Edition Published/ Dernière édition publiée	Min. Protective Surface Required / Surface de protection min. requise : 8.8 m (28'-10") x 6.6 m (21'-8")	Equipment Dimensions / Dimensions de l'équipement : 5.1 m (16'-10") x 2.9 m (9'-8")	Approval date: 19/06/2019 Rev: 00 Initial: TLG 
	Recommended Ages / Âges recommandés : 18 months to 12 years old / 18 mois à 12 ans	Capacity / Peut accueillir : up to 25 children / Jusqu'à 25 enfants	



23 ch. Boom Lane, Unit/Unité E, Industrial Park/Parc industriel  
Atholville, New/Nouveau-Brunswick  
Canada, E3N 4E8  
Tel/tél. : 1-888-212-1411 - Fax/télé. : 1-888-789-0987  
contact@kangoroo.com / www.kangoroo.com

**ZONE DE PROTECTION:**

Chaque équipement doit avoir une zone de protection constituée d'une surface sans obstacle qui se prolonge dans toutes les directions à partir du périmètre de l'équipement. Cette zone doit contenir un revêtement de surface (gravillon, sable, etc...) avec une capacité d'amortissement selon les normes CSA-Z614. Sauf avis contraire.

Zone de protection minimum requise:

8.8 m (28'-10")  
x  
6.6 m (21'-8")

- Aire : 53.31 m ca.  
(573.94 pi. ca.)  
- Périmètre : 27.44 m  
(90'-0")

**PROTECTIVE SURFACING ZONE :**

Each equipment shall have a protective surfacing zone that consist of obstacle-free surfacing surrounding the equipment. This zone shall contain shock absorbing material (pea gravel, sand, etc...) that comply with CSA-Z614. Unless noted otherwise.

Minimum  
Protective Surfacing Zone required:

8.8 m (28'-10")  
x  
6.6 m (21'-8")

- Surface: 53.31 sq. m  
(573.94 sq. ft.)  
- Perimeter: 27.44 m  
(90'-0")

**MÉTHODES D'INSTALLATION**

①

**DANS LE BÉTON:**

- Quantité de Sonotube de 12" Ø x 12' : 2

Béton :  
- 0.5 m. cu.  
(0.6 vge cu.)



①

**CONCRETE:**

- Quantity of Sonotube of 12" Ø x 12': 2

Concrete:  
- 0.5 cu. m.  
(0.6 cu. yd.)

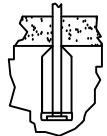

②

**SYSTÈME AUTO-PORTANT:**

Qté charpentes: 3

Béton :  
- 0 m. cu.  
(0 vge cu.)

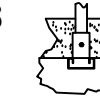

②

**FREE-STANDING SYSTEM:**

Frame QTY: 3

Concrete:  
- 0 cu. m.  
(0 cu. yd.)



**Attention :**

**AIRE DE CIRCULATION LIBRE:**

Aire dégagée d'obstacle qui se prolonge sur au moins 1.8m (70.87") au delà de la zone de protection. Voir dessin pour les détails.

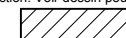

**Warning:**

**NO-ENCROACHMENT ZONE :**

Obstacle-free zone extending at least 1.8m (70.87") beyond the protective surfacing zone. See drawing for details.

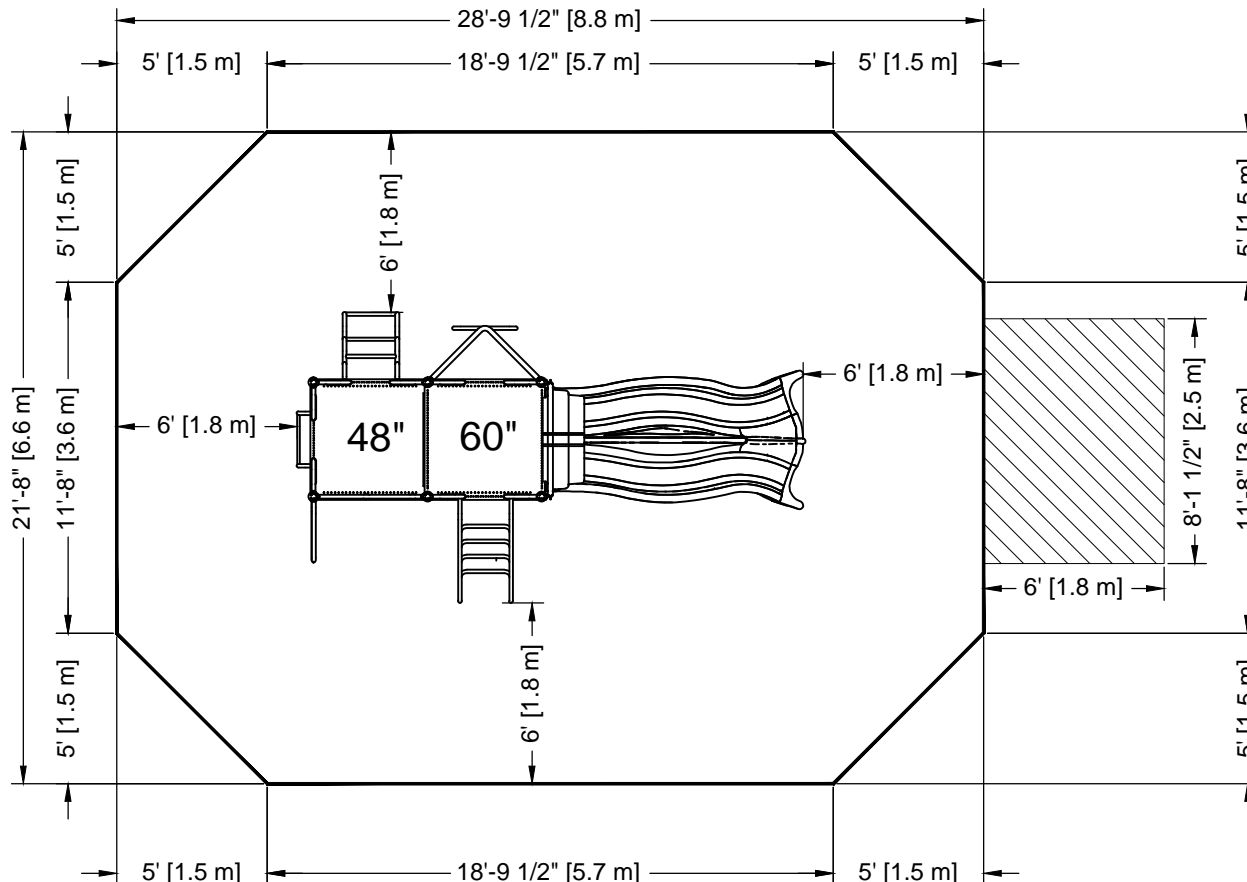
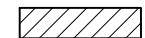

PLATFORM HEIGHTS  
HAUTEURS DE PLATEFORME

12" = 305MM	60" = 1524MM
24" = 609MM	72" = 1829MM
36" = 915MM	84" = 2134MM
48" = 1219MM	96" = 2438MM

<b>Kkids-159</b>	Equipment Dimensions / Dimensions de l'équipement : 5.1 m (16'-10") x 2.9 m (9'-8")	Recommended Ages / Âges recommandés : 18 months to 12 years old 18 mois à 12 ans	Fall Height / Hauteur de chute: 2.59m (8'-6")	Approval date: 19-06-2019 Rev: 00 Initial: TLG
	CAN/CSA-Z614-xx xx: Last Edition Published / Dernière édition publiée			

