



23 ch. Boom Lane, Unit/Unité E, Industrial Park/Parc industriel
 Atholville, New-Brunswick, Canada, E3N 4E8
 Tel/tél. : 1-888-212-1411, Fax. : 1-888-789-0987
 contact@kangaroo.com / www.kangaroo.com



Colors / Couleurs

Post / Poteaux: Blue / bleu

Accent Color / Couleur complémentaire:
 Orange / orange

1 Color panel / Panneaux 1 couleur: Blue / bleu

2 colors panel / Panneaux 2 couleurs :
 N/A

Slide / Glissoire: Gecko Green / vert gecko

Plastic Climbers / Grimpeur Plastique:
 N/A

Cable / Cable : Blue / bleu

Roof / Toît : N/A

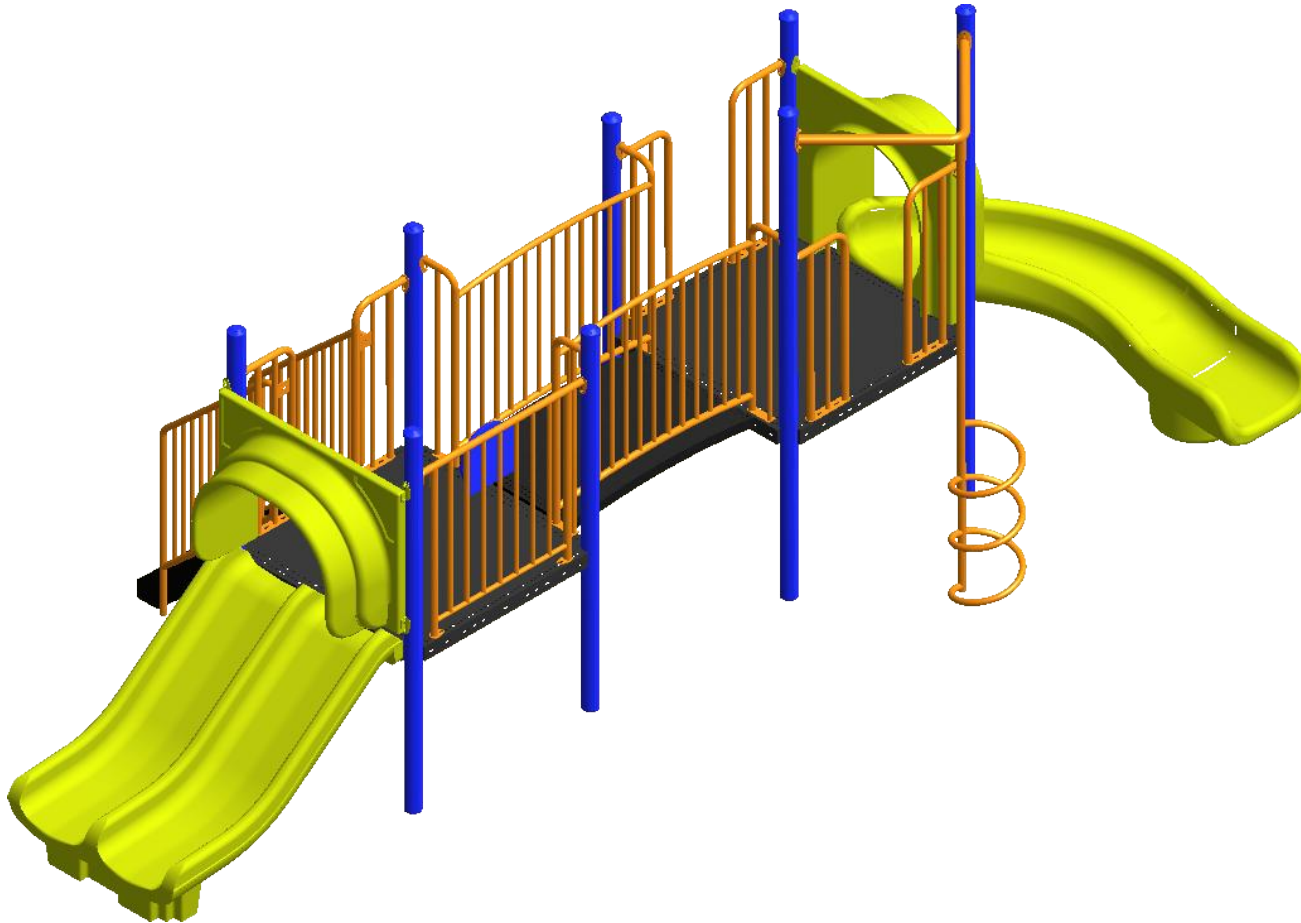

Kkids-154

Min. Protective Surface Required / Surface de protection min. requise :
 10.2 m (33'-7") x 6.7 m (21'-11")

Equipment Dimensions / Dimensions de l'équipement :
 6.6 m (21'-7") x 3.0 m (9'-11")

Approval date: 02/05/2017

Rev: 00

Initial: AMR

CAN/CSA-Z614-xx
 xx: Last Edition Published/
 Dernière édition publiée

Recommended Ages / Âges recommandés :
 18 months to 12 years old / 18 mois à 12 ans

Capacity / Peut accueillir :
 up to 25 children / Jusqu'à 25 enfants





23 ch. Boom Lane, Unit/Unité E
 Industrial Park/Parc industriel
 Atholville, New/Novembre-Brunswick
 Canada, E3N 4E8
 Tel/tél. : 1-888-212-1411/Fax/télééc. : 1-888-789-0987
 www.kangaroo.com

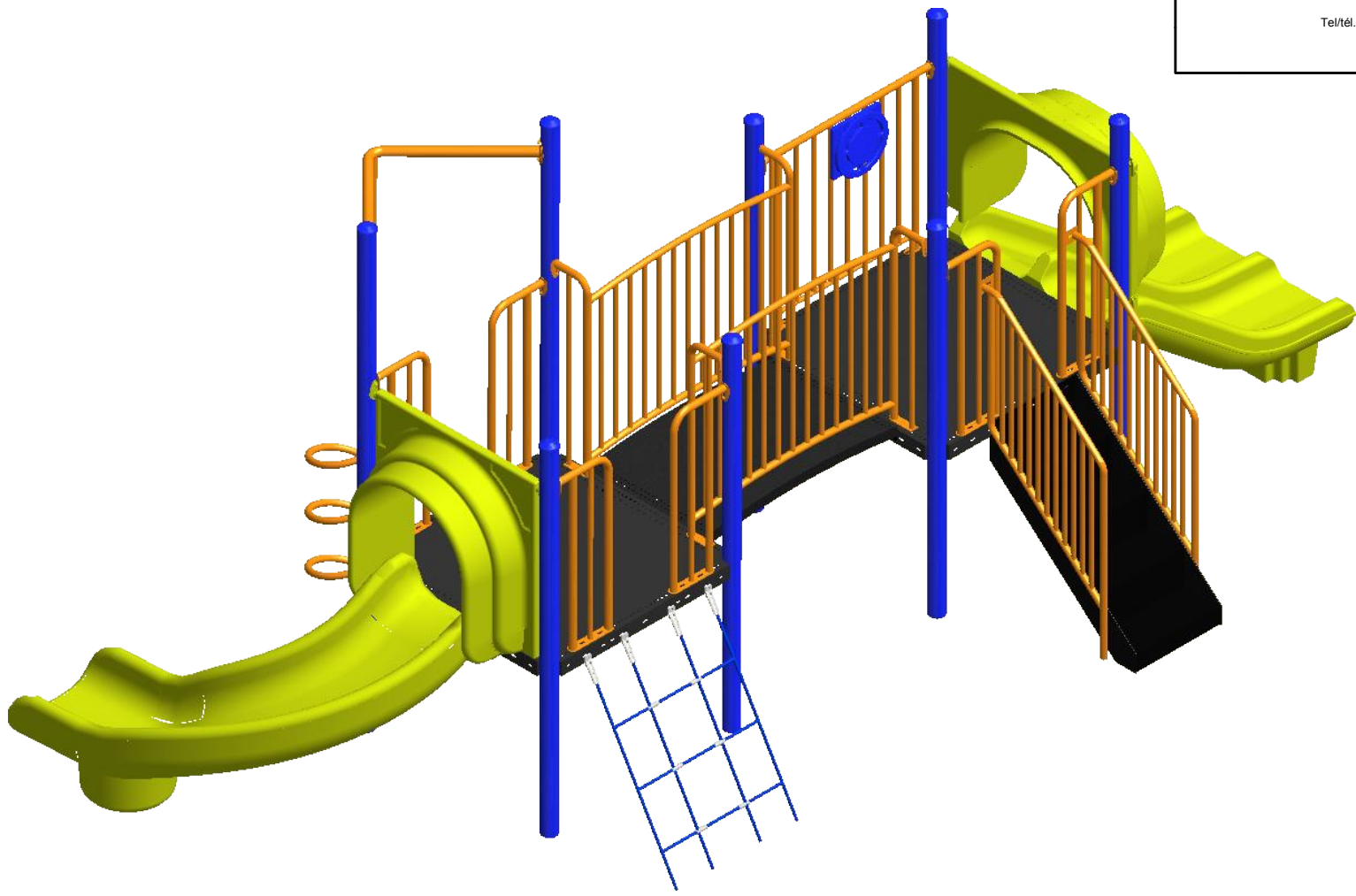

Kkids-154	Min. Protective Surface Required / Surface de protection min. requise : 10.2 m (33'-7") x 6.7 m (21'-11")	Equipment Dimensions / Dimensions de l'équipement : 6.6 m (21'-7") x 3.0 m (9'-11")	Approval date: 02/05/2017 Rev: 00 Initial: AMR
CAN/CSA-Z614-xx xx: Last Edition Published/ Dernière édition publiée	Recommended Ages / Âges recommandés : 18 months to 12 years old / 18 mois à 12 ans	Capacity / Peut accueillir : up to 25 children / Jusqu'à 25 enfants	



23 ch. Boom Lane, Unit/Unité E
 Industrial Park/Parc industriel
 Atholville, New/Nouveau-Brunswick
 Canada, E3N 4E8
 Tel/tél. : 1-888-212-1411/Fax/télééc. : 1-888-789-0987
 www.kangaroo.com

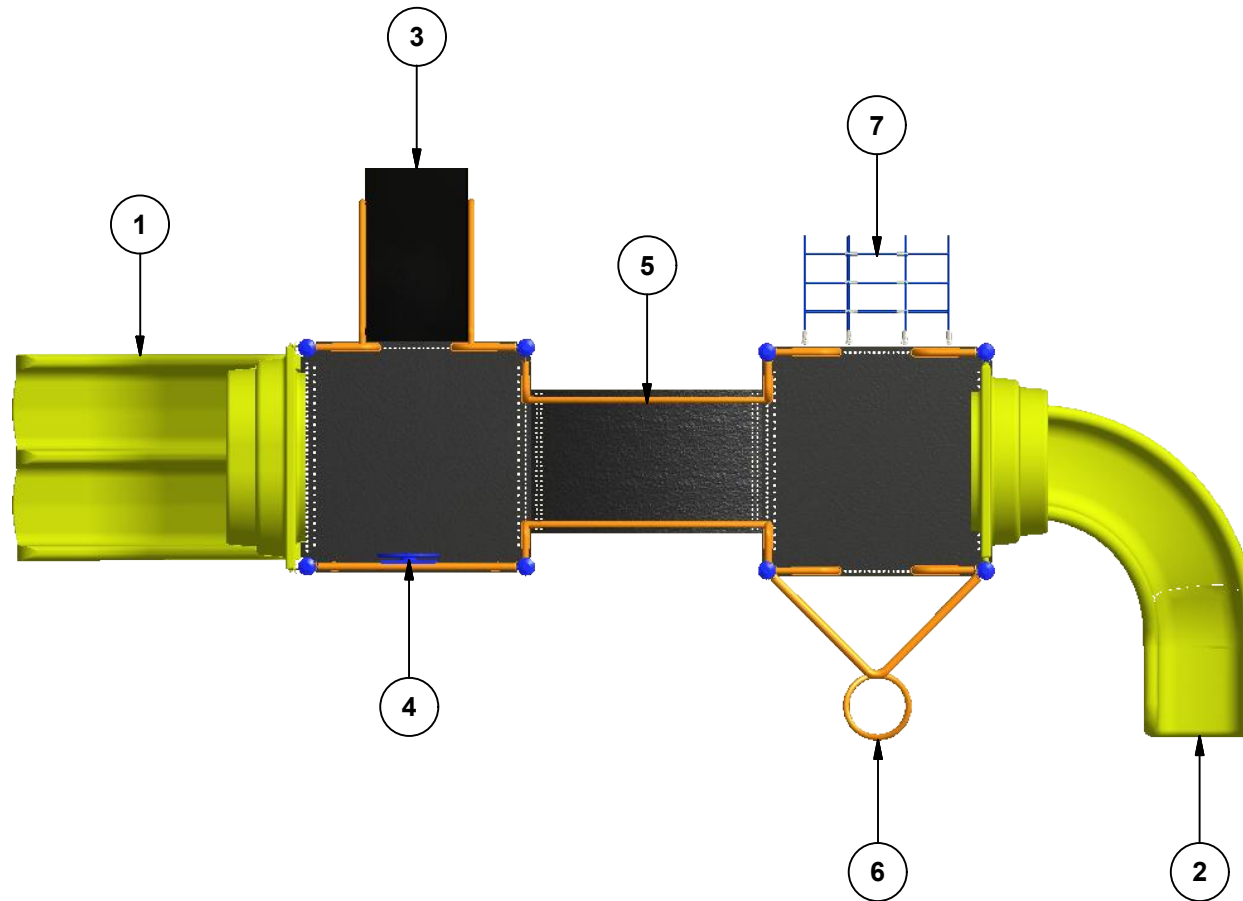

Legend / Légende

ITEM	QTY	Description	PART # / # PIECE
1	1	Triple Rail Slide 36"/Glissoire double 36"	FS-3TRS
2	1	Right Curved Slide 36"/Glissoire courbée à la droite 36"	FS-3CURVED-N
3	1	Full Hand Rail Stairs 36"/Escaliers à main courante pleine 36"	FS-STAIR-36
4	1	Car Panel / Panneau auto	AC-CAR
5	1	Arch Bridge 48"/Pont en arche 48"	ARC-BRI-48
6	1	Spiral Climber 36"/Grimpeur Spiral 36"	FS-SPR-CL-36
7	1	Triple Cable Climber / Grimpeur en cable triple	CL-TRP-CBL-36"

Kkids-154

CAN/CSA-Z614-xx
 xx: Last Edition Published/
 Dernière édition publiée

Min. Protective Surface Required / Surface de protection min. requise :
 10.2 m (33'-7") x 6.7 m (21'-11")

Recommended Ages / Âges recommandés :
 18 months to 12 years old / 18 mois à 12 ans

Equipment Dimensions / Dimensions de l'équipement :
 6.6 m (21'-7") x 3.0 m (9'-11")

Capacity / Peut accueillir :
 up to 25 children / Jusqu'à 25 enfants

Approval date: 02/05/2017
 Rev: 00
 Initial: AMR





23 ch. Boom Lane, Unit/Unité E, Industrial Park/Parc industriel
 Atholville, New/Nouveau-Brunswick
 Canada, E3N 4E8
 Tel/tél. : 1-888-212-1411 - Fax/télec. : 1-888-789-0987
 contact@kangoroo.com / www.kangoroo.com

ZONE DE PROTECTION:

Chaque équipement doit avoir une zone de protection constituée d'une surface sans obstacle qui se prolonge dans toutes les directions à partir du périmètre de l'équipement. Cette zone doit contenir un revêtement de surface (gravillon, sable, etc...) avec une capacité d'amortissement selon les normes CSA-Z614. Sauf avis contraire.

Zone de protection minimum requise:

10.2 m (33'-7")
 x
 6.7 m (21'-11")

- Aire : 59.84 m ca.
 (644.14 pi. ca.)
 - Périmètre : 29.29 m
 (96'-1")

PROTECTIVE SURFACING ZONE :

Each equipment shall have a protective surfacing zone that consist of obstacle-free surfacing surrounding the equipment. This zone shall contain shock absorbing material (pea gravel, sand, etc...) that comply with CSA-Z614. Unless noted otherwise.

Minimum Protective Surfacing Zone required:

10.2 m (33'-7")
 x
 6.7 m (21'-11")

- Surface: 59.84 sq. m
 (644.14 sq. ft.)
 - Perimeter: 29.29 m
 (96'-1")

MÉTHODES D'INSTALLATION

1

DANS LE BÉTON:

- Quantité de Sonotube de 12" Ø x 12' :2

Béton :
 - 0.61 m. cu.
 (0.8 vge cu.)

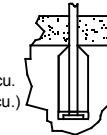

2

SYSTÈME AUTO-PORTANT:

Qté charpentes: 4
 Béton :
 - 0.00 m. cu.
 (0.0 vge cu.)



INSTALLATION METHODES

1

CONCRETE:

- Quantity of Sonotube of 12" Ø x 12':2

Concrete:
 - 0.61 cu. m.
 (0.8 cu. yd.)

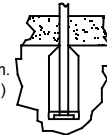

2

FREE-STANDING SYSTEM:

Frame QTY: 4
 Concrete:
 - 0.00 cu. m.
 (0.0 cu. yd.)

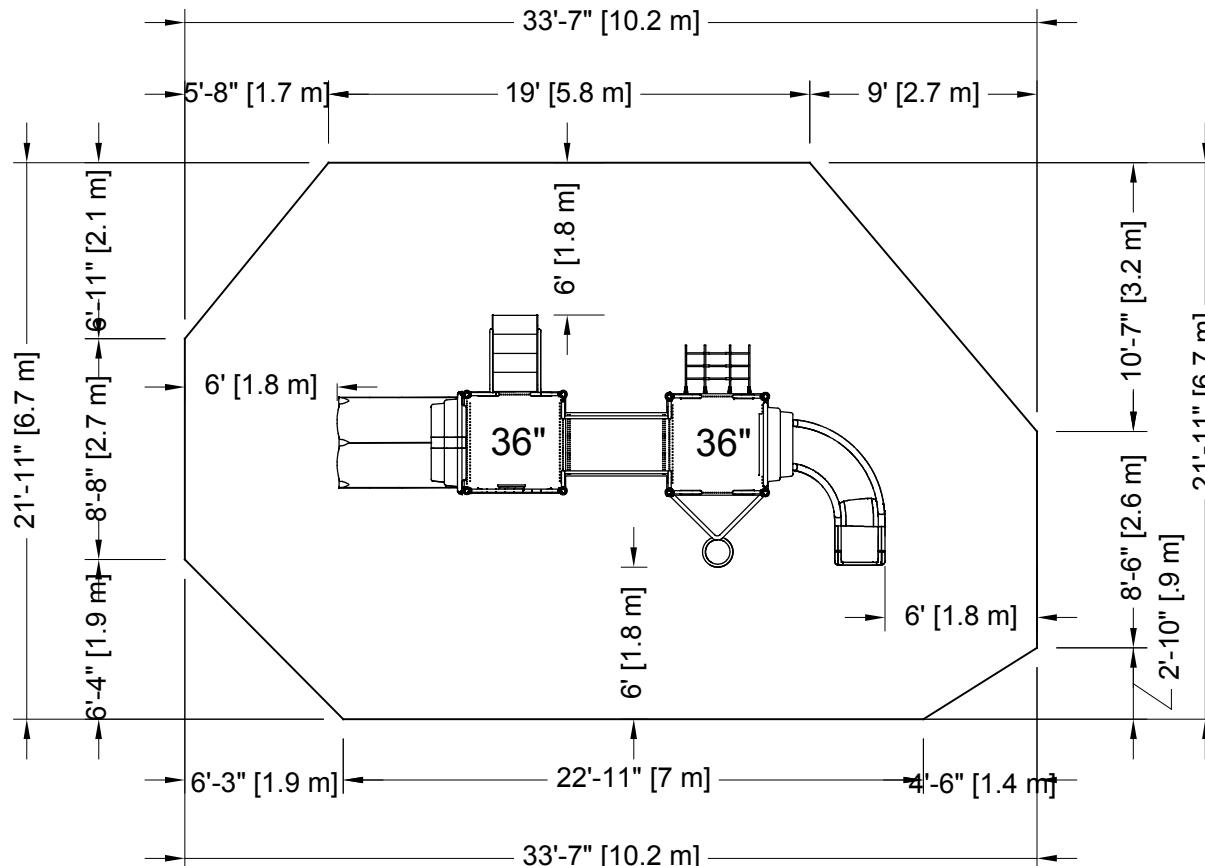
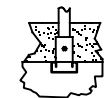

PLATFORM HEIGHTS
HAUTEURS DE PLATEFORME

12" = 305MM	60" = 1524MM
24" = 609MM	72" = 1829MM
36" = 915MM	84" = 2134MM
48" = 1219MM	96" = 2438MM



Attention :

AIRE DE CIRCULATION LIBRE:
 Aire dégagée d'obstacle qui se prolonge sur au moins 1.8m (70.87") au delà de la zone de protection. Voir dessin pour les détails.

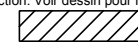

Warning:

NO-ENCROACHMENT ZONE :
 Obstacle-free zone extending at least 1.8m (70.87") beyond the protective surfacing zone. See drawing for details.

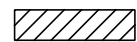

Kkids-154 CAN/CSA-Z614-xx xx: Last Edition Published / Dernière édition publiée	Equipment Dimensions / Dimensions de l'équipement : 6.6 m (21'-7") x 3.0 m (9'-11")	Recommended Ages / Âges recommandés : 18 months to 12 years old 18 mois à 12 ans	Fall Height / Hauteur de chute: 1.98 m (6'-6")	Approval date: 03-05-2017 Rev: 00 Initial: AMR 
	Capacity / Peut accueillir : up to 25 children / Jusqu'à 25 enfants			