



23 ch. Boom Lane, Unit/Unité E  
 Industrial Park/Parc industriel  
 Atholville, New/Nouveau-Brunswick  
 Canada, E3N 4E8  
 Tel/tél. : 1-888-212-1411/Fax/télec. : 1-888-789-0987  
 contact@kangoroo.com / www.kangoroo.com

### Colors / Couleurs

Post / Poteaux: Spring Green/Vert printanier

Accent Color / Couleur complémentaire:  
 Orange/Orange

1 Color panel / Panneaux 1 couleur: NA

2 colors panel / Panneaux 2 couleurs :  
 Blue & Yellow/Bleu et jaune

Slide / Glissoire: Blue/Bleu

Plastic Climbers / Grimpeur Plastique:  
 NA

Cable / Cable : NA

Roof / Toît : Blue/Bleu

### Kkids-144

Min. Protective Surface Required / Surface de protection min. requise :  
 9.3 m (30'-5") x 8.6 m (28'-4")

Equipment Dimensions / Dimensions de l'équipement :  
 5.6 m (18'-5") x 5.0 m (16'-4")

Approval date: 27/09/2016

Rev: 01

Initial: TLG

CAN/CSA-Z614-xx  
 xx: Last Edition Published/  
 Dernière édition publiée

Recommended Ages / Âges recommandés :  
 18 months to 12 years old / 18 mois à 12 ans

Capacity / Peut accueillir :  
 up to 25 children / Jusqu'à 25 enfants



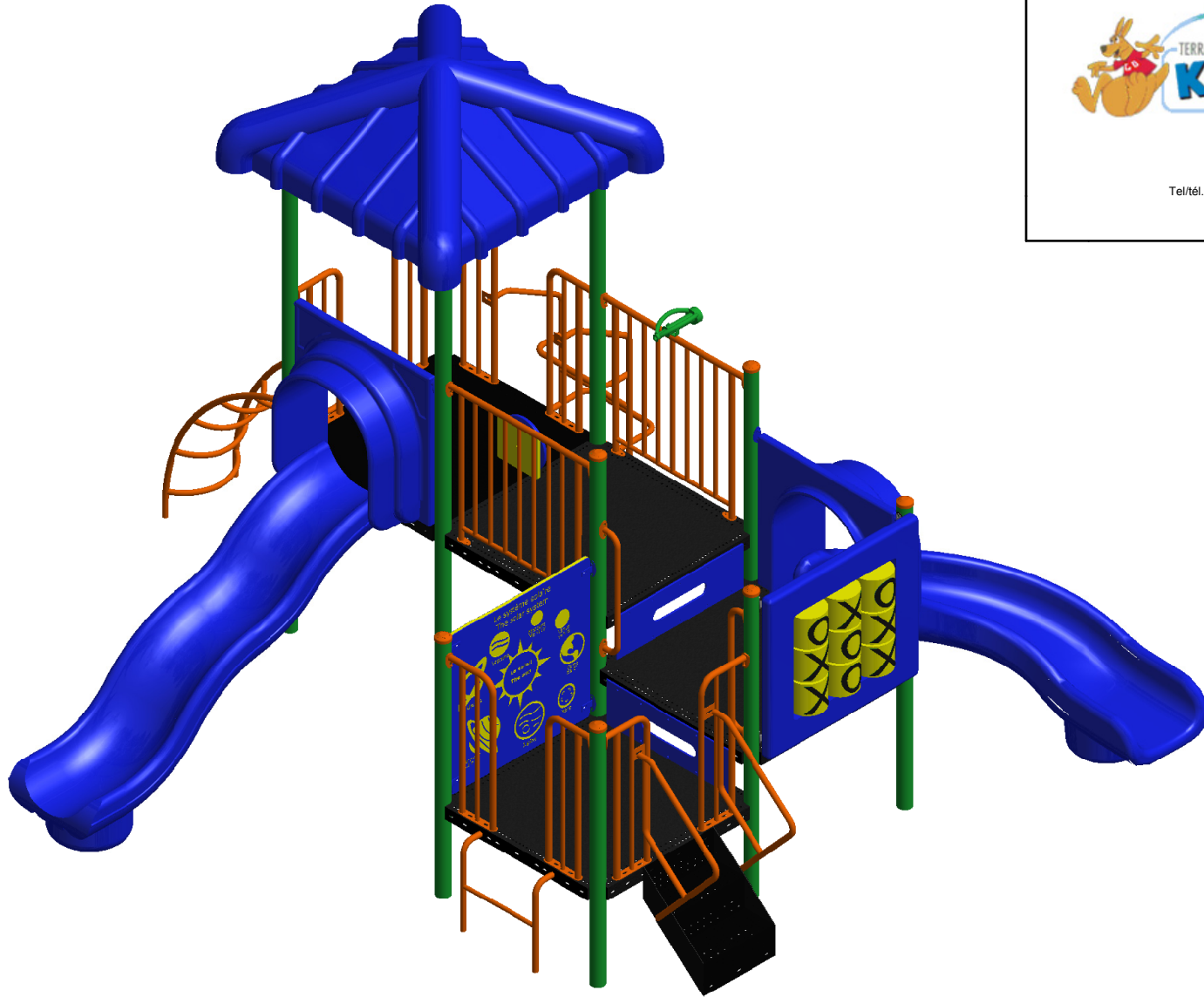

23 ch. Boom Lane, Unit/Unité E  
 Industrial Park/Parc industriel  
 Atholville, New/Novveau-Brunswick  
 Canada, E3N 4E8  
 Tel/tél. : 1-888-212-1411/Fax/télééc. : 1-888-789-0987  
 www.kangoroo.com

<b>Kkids-144</b>	Min. Protective Surface Required / Surface de protection min. requise : 9.3 m (30'-5") x 8.6 m (28'-4")	Equipment Dimensions / Dimensions de l'équipement : 5.6 m (18'-5") x 5.0 m (16'-4")	Approval date: 27/09/2016 Rev: 01 Initial: TLG
CAN/CSA-Z614-xx xx: Last Edition Published/ Dernière édition publiée	Recommended Ages / Âges recommandés : 18 months to 12 years old / 18 mois à 12 ans	Capacity / Peut accueillir : up to 25 children / Jusqu'à 25 enfants	



23 ch. Boom Lane, Unit/Unité E  
 Industrial Park/Parc industriel  
 Atholville, New/Novéau-Brunswick  
 Canada, E3N 4E8  
 Tel/tél. : 1-888-212-1411/Fax/télééc. : 1-888-789-0987  
 www.kangaroo.com



<b>Kkids-144</b>	Min. Protective Surface Required / Surface de protection min. requise : 9.3 m (30'-5") x 8.6 m (28'-4")	Equipment Dimensions / Dimensions de l'équipement : 5.6 m (18'-5") x 5.0 m (16'-4")	Approval date: 27/09/2016 Rev: 01 Initial: TLG
CAN/CSA-Z614-xx xx: Last Edition Published/ Dernière édition publiée	Recommended Ages / Âges recommandés : 18 months to 12 years old / 18 mois à 12 ans	Capacity / Peut accueillir : up to 25 children / Jusqu'à 25 enfants	



23 ch. Boom Lane, Unit/Unité E  
 Industrial Park/Parc industriel  
 Atholville, New/Nouveau-Brunswick  
 Canada, E3N 4E8  
 Tel/tél. : 1-888-212-1411/Fax/télééc. : 1-888-789-0987  
 www.kangaroo.com

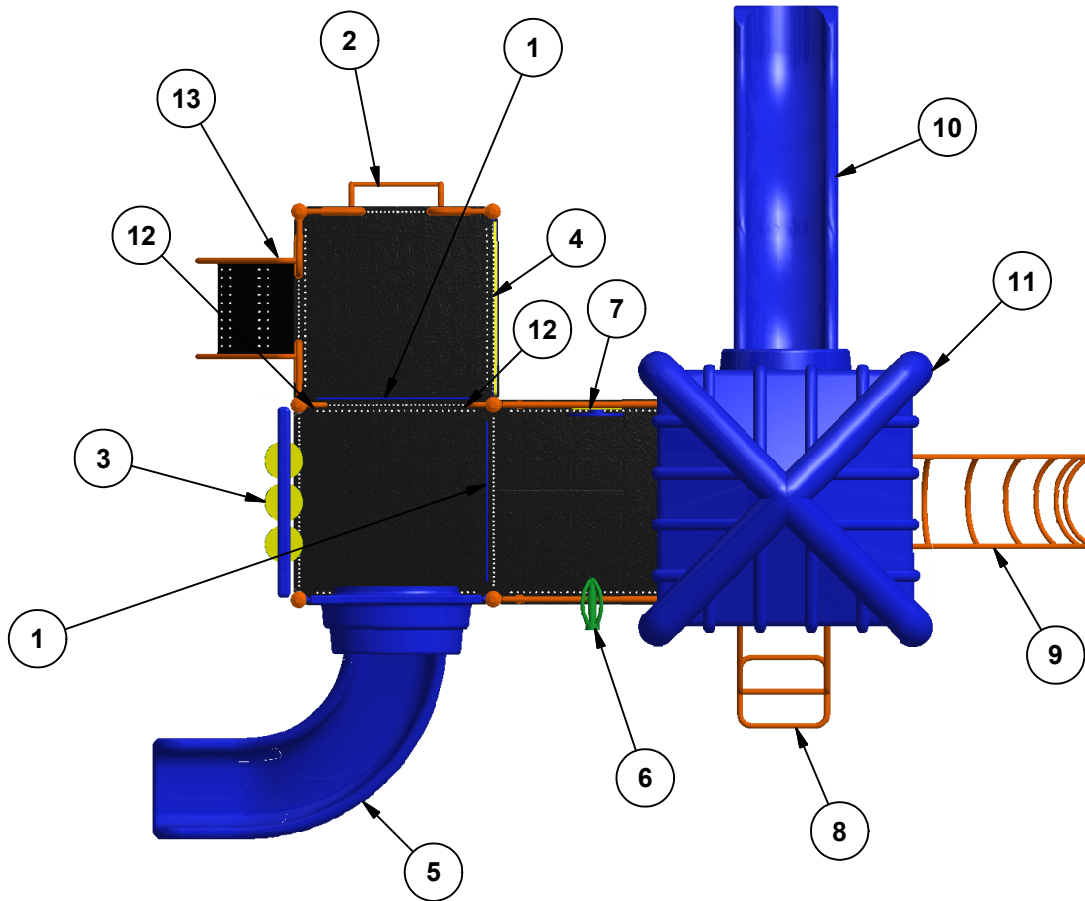

Legend / Légende

ITEM	QTY	Description	PART # / # PIECE
1	2	Riser 12"/contre-marche 12"	Riser-12
2	1	Ground to Deck Rung Ladder 24"/ Échelle à barreaux sol à plateforme 24"	FS-RG-LA-GTD-24
3	1	Tic-Tac-Toe Panel / Panneau tic-tac-toe	AC-TTT
4	1	KG Solar System / Panneau système solaire KG	KG-Solar
5	1	Right Curved Slide 36"/Glissoire courbée a la droite 36"	FS-3CURVED-N
6	1	Telescope Panel / Panneau télescope	AC-TELE
7	1	Car Panel / Panneau auto	AC-CAR
8	1	Loop Climber 48"/ Échelle à boucles 48"	FS-LO-CL-48
9	1	Loop Arch Climber 48"/ Grimpeur à boucles en arche 48"	FS-LARCH-48
10	1	Wavy Double Wall Slide 48" / Glissoire en vague 48"	FS-4DWWS
11	1	Double Wall Pyramid Roof/toit pyramide a double paroi	PYRA-RF
12	2	Transfer support / Support de transfer	R10P
13	1	Stairs 24"/ Escaliers 24"	FS-STAIRS-24

**Kkids-144**

Min. Protective Surface Required / Surface de protection min. requise :  
 9.3 m (30'-5") x 8.6 m (28'-4")

Equipment Dimensions / Dimensions de l'équipement :  
 5.6 m (18'-5") x 5.0 m (16'-4")

Approval date: 27/09/2016  
 Rev: 01  
 Initial: TLG

CAN/CSA-Z614-xx  
 xx: Last Edition Published/  
 Dernière édition publiée

Recommended Ages / Âges recommandés :  
 18 months to 12 years old / 18 mois à 12 ans

Capacity / Peut accueillir :  
 up to 25 children / Jusqu'à 25 enfants





23 ch. Boom Lane, Unit/Unité E, Industrial Park/Parc industriel  
 Atholville, New/Nouveau-Brunswick  
 Canada, E3N 4E8  
 Tel/tél. : 1-888-212-1411 - Fax/télec. : 1-888-789-0987  
 contact@kangoroo.com / www.kangoroo.com

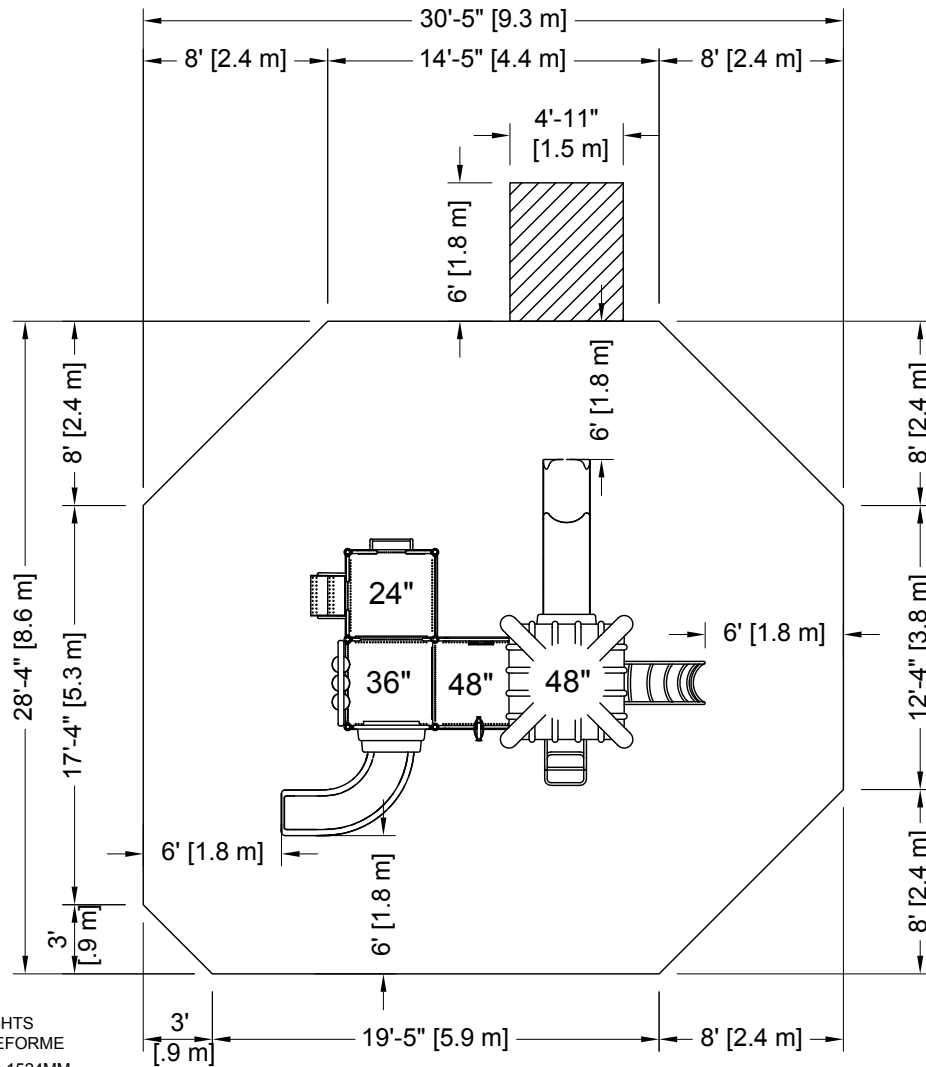

**PLATFORM HEIGHTS**  
**HAUTEURS DE PLATEFORME**

12" = 305MM	60" = 1524MM
24" = 609MM	72" = 1829MM
36" = 915MM	84" = 2134MM
48" = 1219MM	96" = 2438MM

**ZONE DE PROTECTION:**

Chaque équipement doit avoir une zone de protection constituée d'une surface sans obstacle qui se prolonge dans toutes les directions à partir du périmètre de l'équipement. Cette zone doit contenir un revêtement de surface (gravillon, sable, etc...) avec une capacité d'amortissement selon les normes CSA-Z614. Sauf avis contraire.

**Zone de protection minimum requise:**

9.3 m (30'-5")  
 x  
 8.6 m (28'-4")

- Aire : 70.62 m ca.  
 (760.12 pi. ca.)  
 - Périmètre : 31.10 m  
 (102'-0")

**PROTECTIVE SURFACING ZONE :**

Each equipment shall have a protective surfacing zone that consist of obstacle-free surfacing surrounding the equipment. This zone shall contain shock absorbing material (pea gravel, sand, etc...) that comply with CSA-Z614. Unless noted otherwise.

**Minimum Protective Surfacing Zone required:**

9.3 m (30'-5")  
 x  
 8.6 m (28'-4")

- Surface: 70.62 sq. m  
 (760.12 sq. ft.)  
 - Perimeter: 31.10 m  
 (102'-0")

**MÉTHODES D'INSTALLATION**

1

**DANS LE BÉTON:**

- Quantité de Sonotube de 12" Ø x 12" : 2

Béton :  
 - 0.76 m. cu.  
 ( 1.0 vge cu.)



1

**CONCRETE:**

- Quantity of Sonotube of 12" Ø x 12": 2

Concrete:  
 - 0.76 cu. m.  
 (1.0 cu. yd.)



2

**SYSTÈME AUTO-PORTANT:**

Qté charpentes: 5  
 Béton :  
 - 0 m. cu.  
 (0 vge cu.)



2

**FREE-STANDING SYSTEM**

Frame QTY: 5  
 Concrete:  
 - 0 cu. m.  
 (0 cu. yd.)



**Attention :**

**AIRE DE CIRCULATION LIBRE:**

Aire dégagée d'obstacle qui se prolonge sur au moins 1.8m (70.87") au delà de la zone de protection. Voir dessin pour les détails.



**Warning:**

**NO-ENCROACHMENT ZONE**

Obstacle-free zone extending at least 1.8m (70.87") beyond the protective surfacing zone. See drawing for details.



**Kkids-144**

CAN/CSA-Z614-xx  
 xx: Last Edition Published /  
 Dernière édition publiée

Equipment Dimensions / Dimensions de l'équipement :  
 5.6 m (18'-5") x 5.0 m (16'-4")

Capacity / Peut accueillir :  
 up to 25 children / Jusqu'à 25 enfants

Recommended Ages / Âges recommandés :  
 18 months to 12 years old  
 18 mois à 12 ans

Fall Height /  
 Hauteur de chute:  
 2.29 m (7'-6")

Approval date: 27-09-2016  
 Rev: 01  
 Initial: TLG

