

23 ch. Boom Lane, Unit/Unité E, Industrial Park/Parc industriel
 Atholville, New-Brunswick, Canada, E3N 4E8
 Tel/tél. : 1-888-212-1411, Fax. : 1-888-789-0987
 contact@kangaroo.com / www.kangaroo.com



Colors / Couleurs

Post / Poteaux: Red/Rouge

Accent Color / Couleur complémentaire:
 Yellow/Jaune

1 Color panel / Panneaux 1 couleur: Blue/Bleu

2 colors panel / Panneaux 2 couleurs :
 NA

Slide / Glissoire: Blue/Bleu

Plastic Climbers / Grimpeur Plastique:
 Blue/Bleu

Cable / Cable : NA

Roof / Toît : Blue/Bleu

Kkids-109

Min. Protective Surface Required / Surface de protection min. requise :
 13.8 m (45'-3") x 7.8 m (25'-8")

Equipment Dimensions / Dimensions de l'équipement :
 10.1 m (33'-3") x 4.2 m (13'-8")

Approval date: 26/10/2017

Rev: 01

Initial: TLG

CAN/CSA-Z614-xx
 xx: Last Edition Published/
 Dernière édition publiée

Recommended Ages / Âges recommandés :
 18 months to 12 years old / 18 mois à 12 ans

Capacity / Peut accueillir :
 up to 35 children / Jusqu'à 35 enfants





23 ch. Boom Lane, Unit/Unité E
 Industrial Park/Parc industriel
 Atholville, New/Neuveau-Brunswick
 Canada, E3N 4E8
 Tel/tél. : 1-888-212-1411/Fax/télééc. : 1-888-789-0987
 www.kangaroo.com

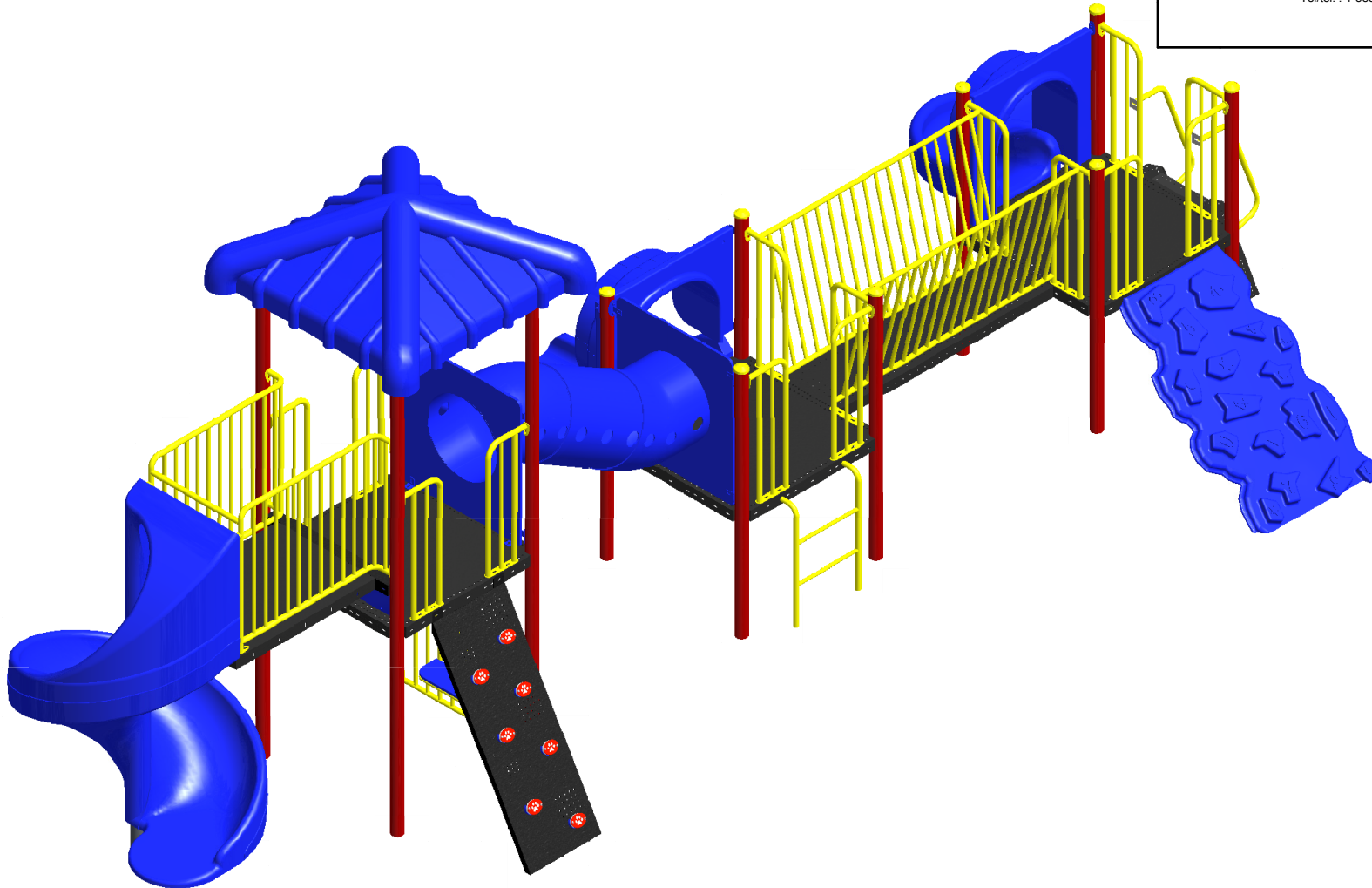

Kkids-109	Min. Protective Surface Required / Surface de protection min. requise : 13.8 m (45'-3") x 7.8 m (25'-8")	Equipment Dimensions / Dimensions de l'équipement : 10.1 m (33'-3") x 4.2 m (13'-8")	Approval date: 26/10/2017 Rev: 01 Initial: TLG
CAN/CSA-Z614-xx xx: Last Edition Published/ Dernière édition publiée	Recommended Ages / Âges recommandés : 18 months to 12 years old / 18 mois à 12 ans	Capacity / Peut accueillir : up to 35 children / Jusqu'à 35 enfants	



23 ch. Boom Lane, Unit/Unité E
 Industrial Park/Parc industriel
 Atholville, New/Nouveau-Brunswick
 Canada, E3N 4E8
 Tel/tél. : 1-888-212-1411/Fax/télééc. : 1-888-789-0987
 www.kangoroo.com

Legend / Légende

ITEM	QTY	Description	PART # / # PIECE
1	1	Step Ladder 36"/Échelle à marche 36"	FS-STP-36
2	1	Fredrock Climber 36"/ Grimpeur Fredrock 36"	FRC-36
3	1	Right Curved Slide 36"/Glissoire courbée a la droite 36"	FS-3CURVED-N
4	1	The CatWalk 72"/ La Passerelle 72"	CAT-WALK-72
5	1	Ground to Deck Rung Ladder 36"/ Échelle à barreaux sol à plateforme 36"	FS-RG-LA-GTD-36
6	1	Triple Rail Slide 36"/Glissoire double 36"	FS-3TRS
7	1	Drop Tunnel / Tunnel incliné	DRP-TUN-24H
8	1	Alpine Wall 60"/ Mur alpin 60"	FS-AC-60
9	1	Triple Chain Climber 60"/ Chaînes à grimper triple 60"	FS-TR-CHN-CL-60
10	1	Open Spiral Slide 72"/ Glissoire Spirale 72"	FS-SPI-SL-72
11	1	Riser 12"/contre-marche 12"	Riser-12
12	1	Double Wall Pyramid Roof/toit pyramide a double paroi	PYRA-RF
13	1	Bench / Banc	AC-BENCH

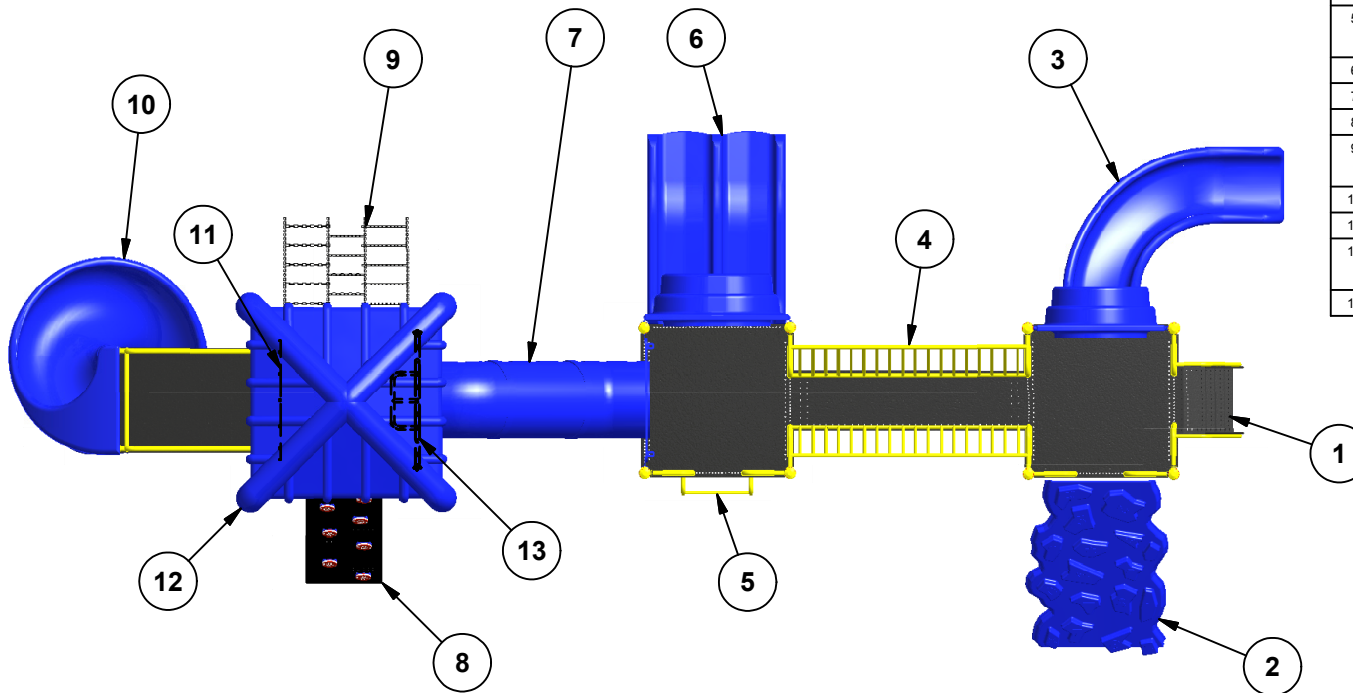

Kkids-109

Min. Protective Surface Required / Surface de protection min. requise :
 13.8 m (45'-3") x 7.8 m (25'-8")

Equipment Dimensions / Dimensions de l'équipement :
 10.1 m (33'-3") x 4.2 m (13'-8")

Approval date: 26/10/2017
 Rev: 01
 Initial: TLG

CAN/CSA-Z614-xx
 xx: Last Edition Published/
 Dernière édition publiée

Recommended Ages / Âges recommandés :
 18 months to 12 years old / 18 mois à 12 ans

Capacity / Peut accueillir :
 up to 35 children / Jusqu'à 35 enfants





23 ch. Boom Lane, Unit/Unité E, Industrial Park/Parc industriel
 Atholville, New/Nouveau-Brunswick
 Canada, E3N 4E8
 Tel/tél. : 1-888-212-1411 - Fax/télé. : 1-888-789-0987
 contact@kangoroo.com / www.kangoroo.com

ZONE DE PROTECTION:

Chaque équipement doit avoir une zone de protection constituée d'une surface sans obstacle qui se prolonge dans toutes les directions à partir du périmètre de l'équipement. Cette zone doit contenir un revêtement de surface (gravillon, sable, etc...) avec une capacité d'amortissement selon les normes CSA-Z614. Sauf avis contraire.

Zone de protection minimum requise:

13.8 m (45'-3")
 x
 7.8 m (25'-8")

- Aire : 100.34 m ca. (1080.05 pi. ca.)
- Périmètre : 39.02 m (128'-0")

PROTECTIVE SURFACING ZONE :

Each equipment shall have a protective surfacing zone that consist of obstacle-free surfacing surrounding the equipment. This zone shall contain shock absorbing material (pea gravel, sand, etc...) that comply with CSA-Z614. Unless noted otherwise.

Minimum Protective Surfacing Zone required:

13.8 m (45'-3")
 x
 7.8 m (25'-8")

- Surface: 100.34 sq. m (1080.05 sq. ft)
- Perimeter: 39.02 m (128'-0")

MÉTHODES D'INSTALLATION

INSTALLATION METHODS

1

DANS LE BÉTON:

- Quantité de Sonotube de 12" Ø x 12' : 3

Béton :
 - 0.92 m. cu. (1.2 vge cu.)



1

CONCRETE:

- Quantity of Sonotube of 12" Ø x 12': 3

Concrete:
 - 0.92 cu. m. (1.2 cu. yd.)

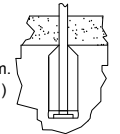

2

SYSTÈME AUTO-PORTANT:

Qté charpentes: 6

Béton :
 - 0 m. cu. (0 vge cu.)



2

FREE-STANDING SYSTEM

Frame QTY: 6

Concrete:
 - 0 cu. m. (0 cu. yd.)



Attention :
AIRE DE CIRCULATION LIBRE:

Aire dégagée d'obstacle qui se prolonge sur au moins 1.8m (70.87") au delà de la zone de protection. Voir dessin pour les détails.

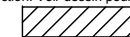

Warning:
NO-ENCROACHMENT ZONE

Obstacle-free zone extending at least 1.8m (70.87") beyond the protective surfacing zone. See drawing for details.

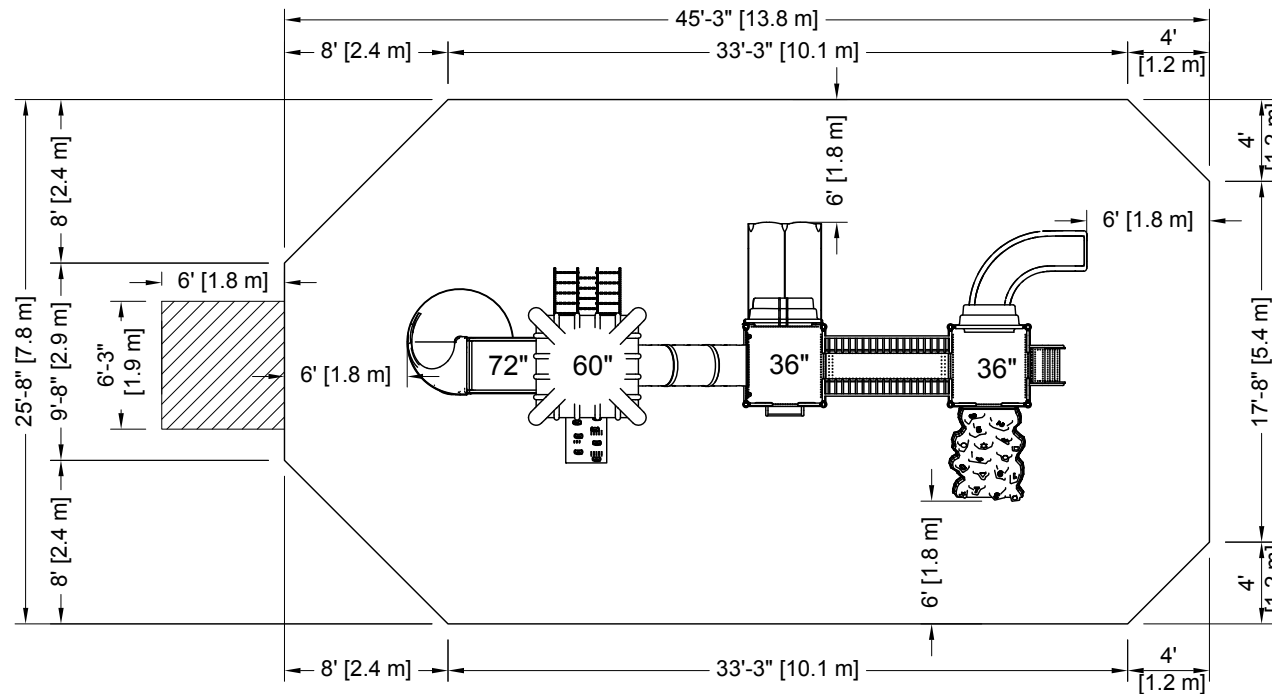

PLATFORM HEIGHTS
HAUTEURS DE PLATEFORME

12" = 305MM	60" = 1524MM
24" = 609MM	72" = 1829MM
36" = 915MM	84" = 2134MM
48" = 1219MM	96" = 2438MM

Kkids-109 CAN/CSA-Z614-xx xx: Last Edition Published / Dernière édition publiée	Equipment Dimensions / Dimensions de l'équipement : 10.1 m (33'-3") x 4.2 m (13'-8")	Recommended Ages / Âges recommandés : 18 months to 12 years old 18 mois à 12 ans	Fall Height / Hauteur de chute: 2.89 m (9'-6")	Approval date: 26-10-2017 Rev: 01 Initial: TLG
	Capacity / Peut accueillir : up to 35 children / Jusqu'à 35 enfants			