

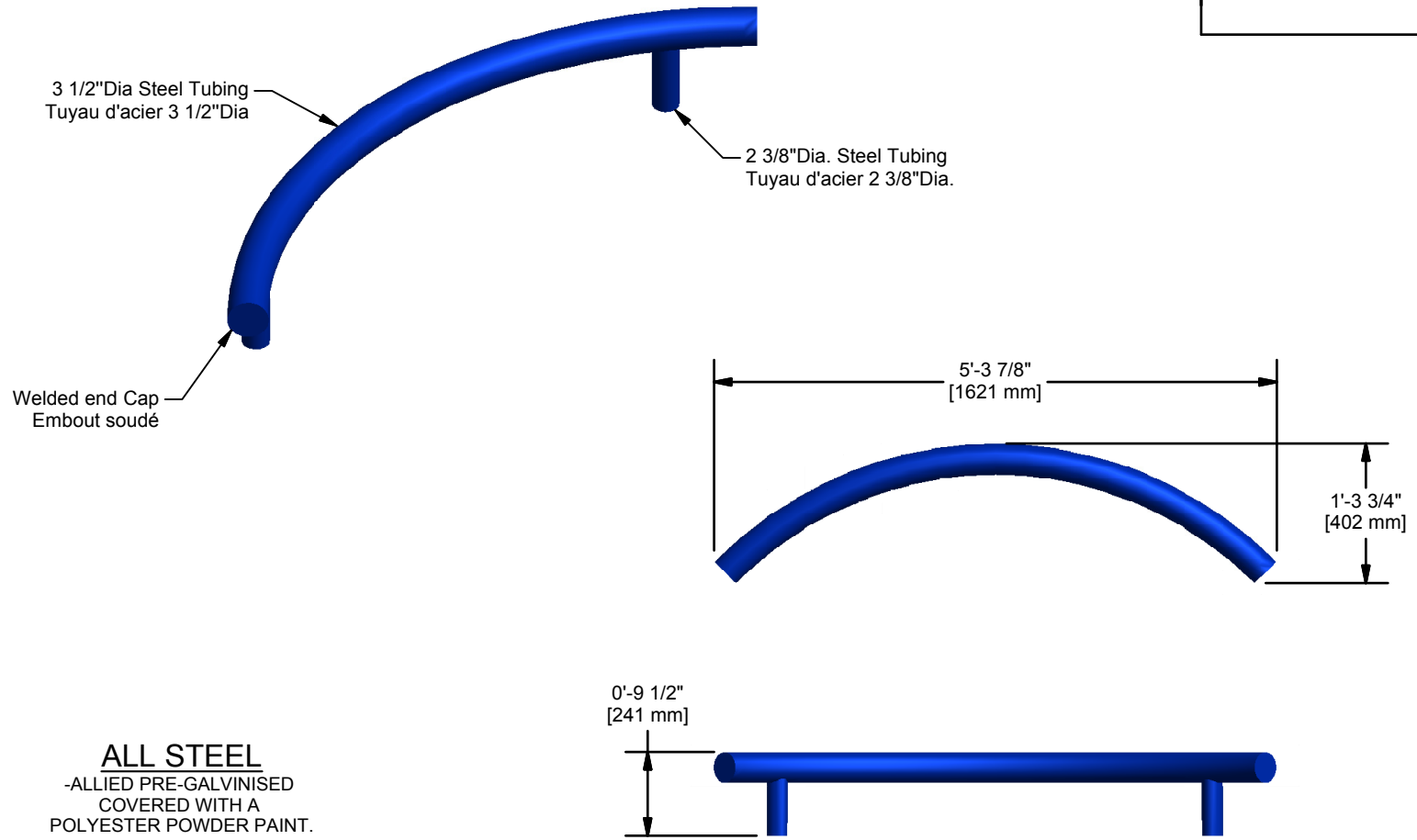



23 ch. Boom Lane, Unit/Unité E
 Industrial Park/Parc industriel
 Atholville, New/Nouveau-Brunswick
 Canada, E3N 4E8
 Tel/tél. : 1-888-212-1411/Fax/télec. : 1-888-789-0987
 contact@kangoroo.com / www.kangoroo.com

Colors / Couleurs
 Bleu / Blue



ALL STEEL
 -ALLIED PRE-GALVINISED
 COVERED WITH A
 POLYESTER POWDER PAINT.
TOUT ACIER
 PRÉ-GALVANISÉ "ALLIED"
 COUVERT D'UNE PEINTURE DE
 POUDRE DE POLYESTER.

EB-204M2	Min. Protective Surface Required / Surface de protection min. requise : 5.2 m (17'-3") x 4.1 m (13'-4")	Equipment Dimensions / Dimensions de l'équipement : 1.6 m (5'-4") x 0.4 m (1'-4")	Approval date: 27/03/2013 Rev: 01 Initial: TLG
CAN/CSA-Z614-xx xx: Last Edition Published/ Dernière édition publiée	Recommended Ages / Âges recommandés : 18 months to 12 years old / 18 mois à 12 ans	Capacity / Peut accueillir : up to 3 children / Jusqu'à 3 enfants	



23 ch. Boom Lane, Unit/Unité E, Industrial Park/Parc industriel
Atholville, New/Nouveau-Brunswick
Canada, E3N 4E8
Tel/tél. : 1-888-212-1411 - Fax/télec. : 1-888-789-0987
contact@kangoroo.com / www.kangoroo.com

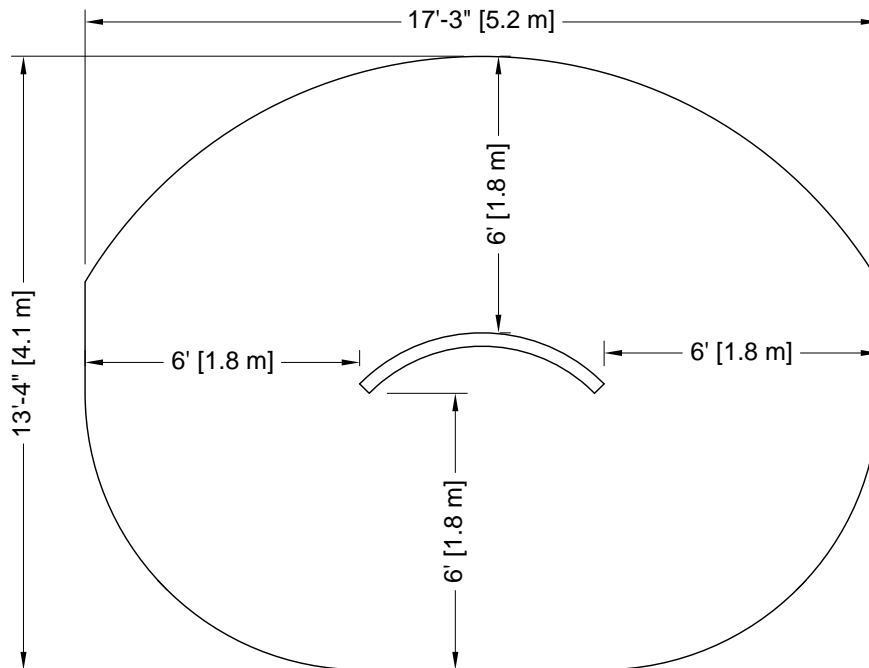

ZONE DE PROTECTION:

Chaque équipement doit avoir une zone de protection constituée d'une surface sans obstacle qui se prolonge dans toutes les directions à partir du périmètre de l'équipement. Cette zone doit contenir un revêtement de surface (gravillon, sable, etc...) avec une capacité d'amortissement selon les normes CSA-Z614. Sauf avis contraire.

Zone de protection minimum requise:

5.2 m (17'-3")
x
4.1 m (13'-4")

- Aire : 17.57 m ca.
(189.18 pi. ca.)

PROTECTIVE SURFACING ZONE:

Each equipment shall have a protective surfacing zone that consist of obstacle-free surfacing surrounding the equipment. This zone shall contain shock absorbing materi: (pea gravel, sand, etc...) that comply with CSA-Z614. Unless noted otherwise.

Minimum Protective Surfacing Zone required:

5.2 m (17'-3")
x
4.1 m (13'-4")

- Surface: 17.57 sq. m
(189.18 sq. ft.)

MÉTHODES D'INSTALLATION

1

DANS LE BÉTON:

- Quantité de Sonotube de 12" Ø x 12" : 1

Béton :
- 0.15 m. cu.
(0.2 vge cu.)



1

CONCRETE:

- Quantity of Sonotube of 12" Ø x 12": 1

Concrete:
- 0.15 cu. m.
(0.2 cu. yd.)

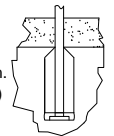

2

SYSTÈME AUTO-PORTANT:

Qté charpentes: 0
Béton :
- na m. cu.
(na vge cu.)



2

FREE-STANDING SYSTEM

Frame QTY: 0
Concrete:
- na cu. m.
(na cu. yd.)



Attention :

AIRE DE CIRCULATION LIBRE:

Aire dégagée d'obstacle qui se prolonge sur au moins 1.8m (70.87") au delà de la zone de protection. Voir dessin pour les détails.



Warning:

NO-ENCROACHMENT ZONE

Obstacle-free zone extending at least 1.8r (70.87") beyond the protectice surfacing zor See drawing for details.



EB-204M2

Equipment Dimensions / Dimensions de l'équipement :
1.6 m (5'-4") x 0.4 m (1'-4")

Recommended Ages / Âges recommandés :
18 months to 12 years old
18 mois à 12 ans

CAN/CSA-Z614-xx
xx: Last Edition Published /
Dernière édition publiée

Capacity / Peut accueillir :
up to 3 children / Jusqu'à 3 enfants

Fall Height /
Hauteur de chute:
.30 m (0'-11-7/8")

Approval date: 27-03-2013
Rev: 01
Initial: TLG

