

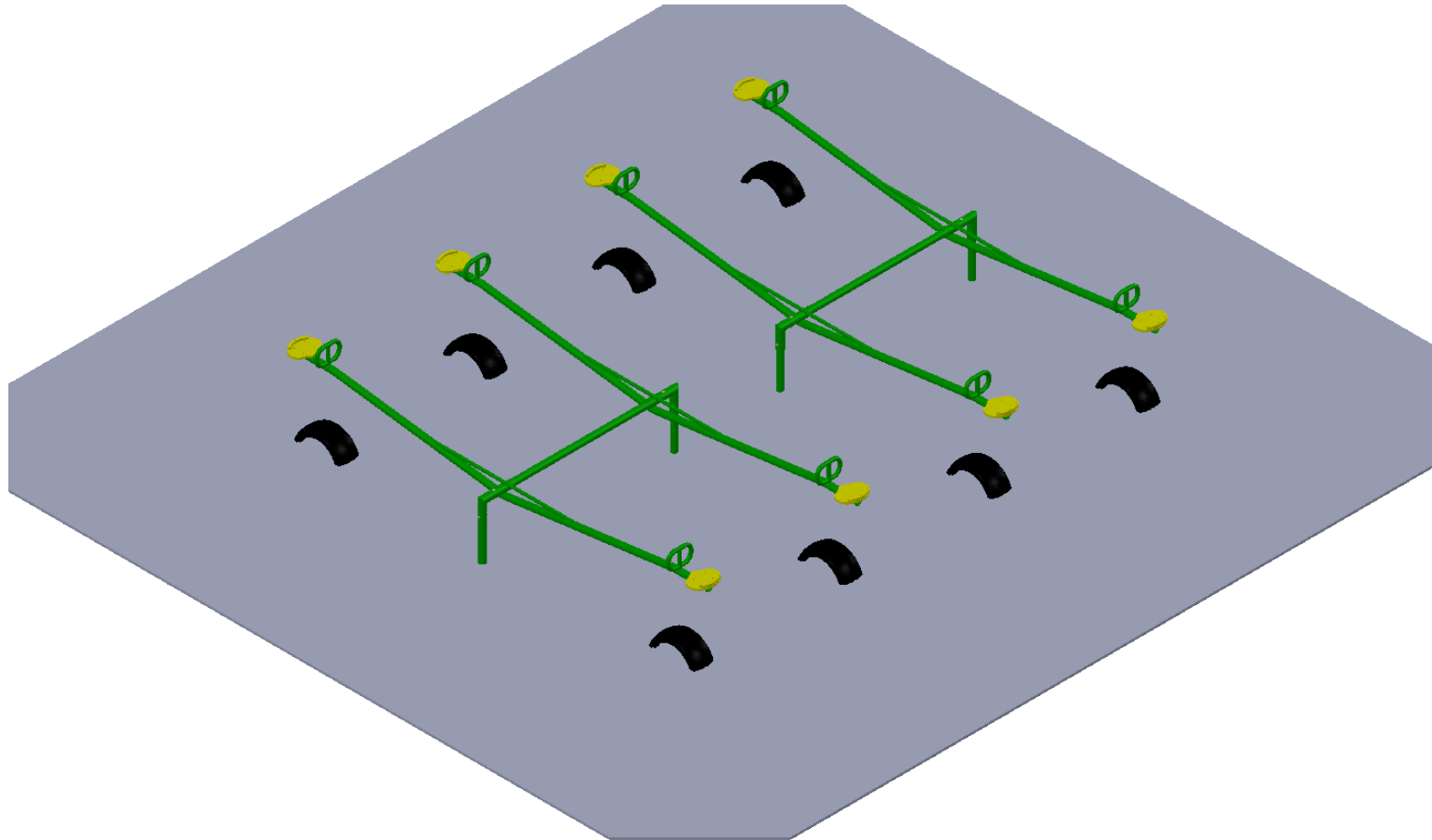

23 ch. Boom Lane, Unit/Unité E Industrial  
 Park/Parc industriel Atholville, New/Nouveau-  
 Brunswick Canada, E3N 4E8  
 Tel/tél. : 1-888-212-1411/Fax/téloc. : 1-888-  
 789-0987 www.kangaroo.com



<p><b>B_412-4</b></p>	<p>Min. Protective Surface Required / Surface de protection min. requise        7.9m (25'11") x 8.45m (27'8 11/16")</p>	<p>Equipment Dimensions / Dimensions de l'équipement :        4.8m (15'8 11/16") x 4.25m (13'11")</p>	<p>Approval date: 2023-06-29        Rev: 00</p>
<p>CAN/CSA-Z614</p>	<p>Recommended Ages / Âges recommandés :        5 years to 12 years old / 5ans à 12 ans</p>	<p>Capacity / Peut accueillir : up to        8 children / Jusqu'à 8 enfants</p>	<p>Initial: O.P.        SHEET 1 OF 4</p>



23 ch. Boom Lane, Unit/Unité E Industrial  
 Park/Parc industriel Atholville, New/Nouveau-  
 Brunswick Canada, E3N 4E8  
 Tel/tél. : 1-888-212-1411/Fax/télé. : 1-888-  
 789-0987 www.kangoroo.com

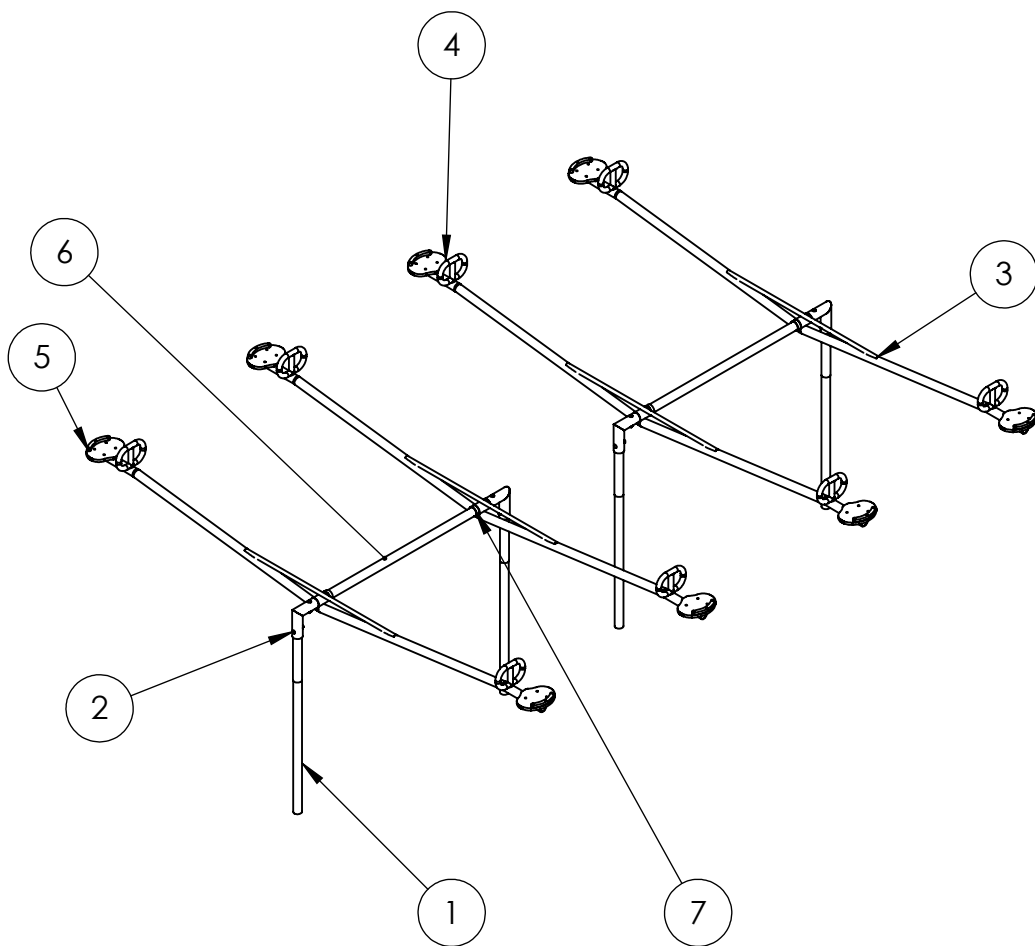

ITEM NO.	PART NUMBER	QTY.
1	PIPE 2 3_8x62	4
2	CORNER PIPE 2 3_4	4
3	Teeter Totter	4
4	Seat	8
5	Seat U	8
6	Pipe 2 3_8 L97 7_16	2
7	STOPPER RING	4

**B\_412-4**

CAN/CSA-Z614

Min. Protective Surface Required / Surface de protection min. requise  
 7.9m (25'11") x 8.45m (27'8 11/16")

Recommended Ages / Âges recommandés :  
 5 years to 12 years old / 5ans à 12 ans

Equipment Dimensions / Dimensions de  
 l'équipement :

4.8m (15'8 11/16") x 4.25m (13'11")

Capacity / Peut accueillir : up to  
 8 children / Jusqu'à 8 enfants

Approval date: 2023-06-29

Rev: 00

Initial: O.P.

SHEET 2 OF 4



23 ch. Boom Lane, Unit/Unité E Industrial  
 Park/Parc industriel Atholville, New/Nouveau-  
 Brunswick Canada, E3N 4E8  
 Tel/tél. : 1-888-212-1411/Fax/télec. : 1-888-  
 789-0987 www.kangaroo.com

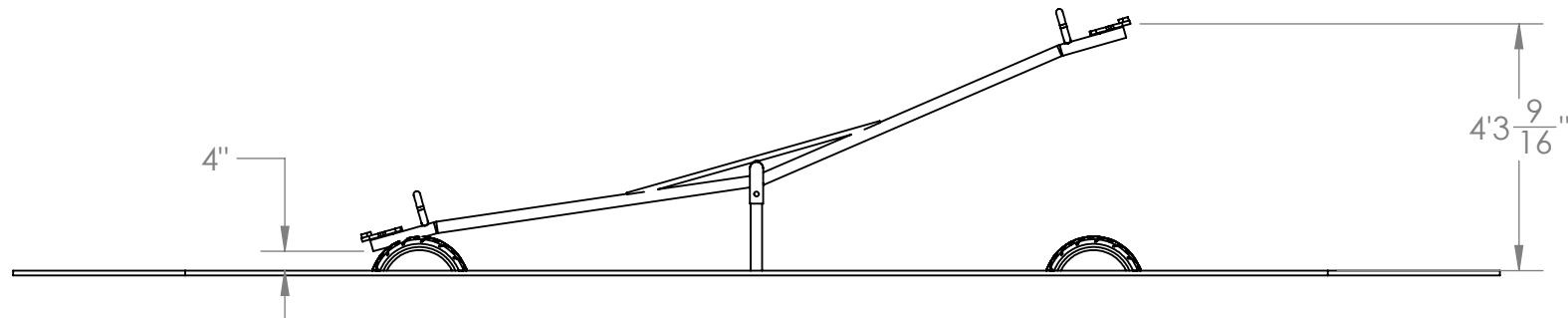

**B\_412-4**

Min. Protective Surface Required / Surface de protection min. requise  
 7.9m (25'11") x 8.45m (27'8 11/16")

Equipment Dimensions / Dimensions de  
 l'équipement :

4.8m (15'8 11/16") x 4.25m (13'11")

Approval date: 2023-06-29

Rev: 00

CAN/CSA-Z614

Recommended Ages / Âges recommandés :  
 5 years to 12 years old / 5ans à 12 ans

Capacity / Peut accueillir : up to  
 8 children / Jusqu'à 8 enfants

Initial: O.P.





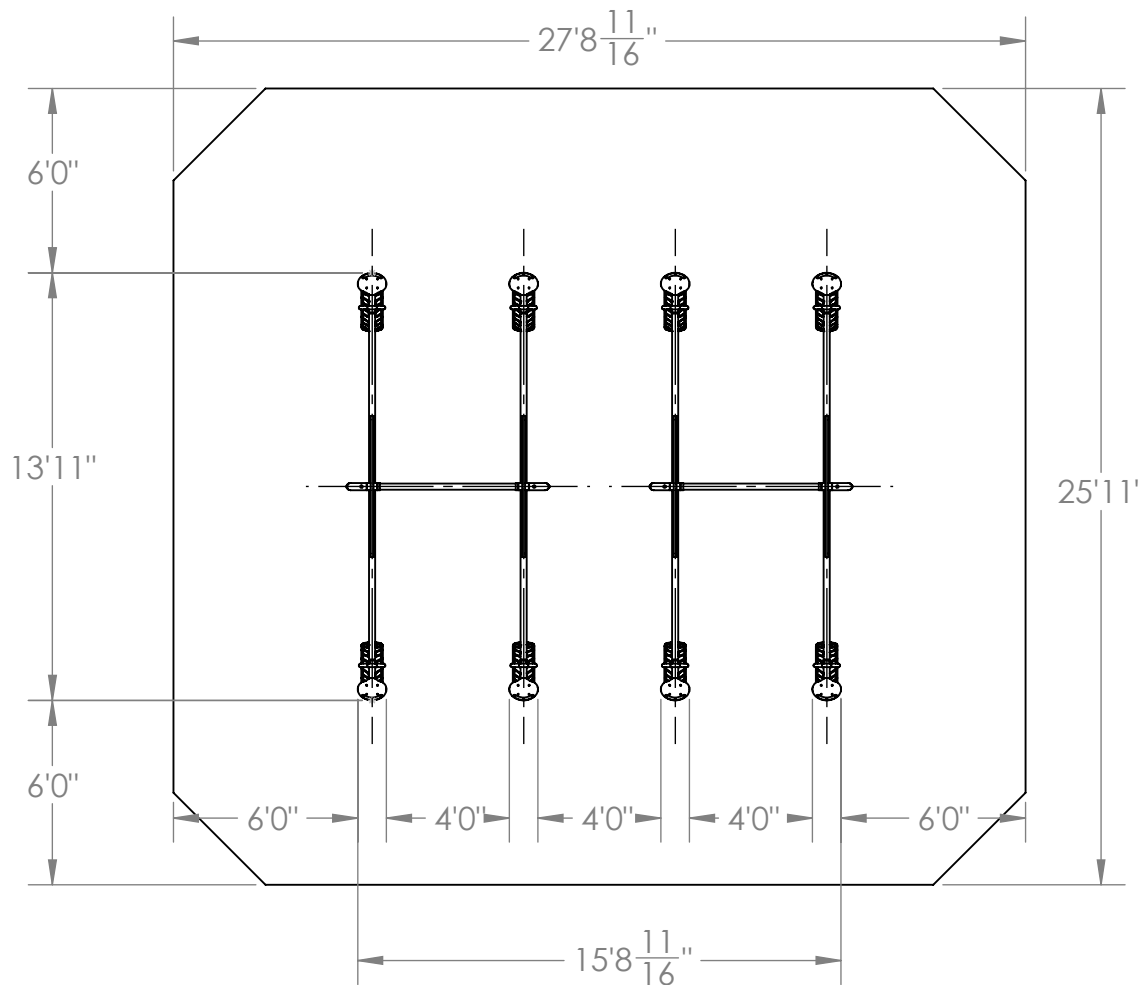



23 ch. Boom Lane, Unit/Unité E Industrial Park/Parc industriel  
 Atholville, New/Nouveau-Brunswick Canada, E3N 4E8  
 Tel/tél. : 1-888-212-1411/Fax/télé. : 1-888-789-0987  
 www.kangoroo.com



PLATFORM HEIGHTS  
 HAUTEURS DE PLATEFORME

12" = 305MM	24" = 609MM
36" = 915MM	48" = 1219MM
60" = 1524MM	72" = 1829MM
84" = 2134MM	96" = 2438MM

<p><b>ZONE DE PROTECTION:</b>          Chaque équipement doit avoir une zone de protection constituée d'une surface sans obstacle qui se prolonge dans toutes les directions à partir du périmètre de l'équipement. Cette zone doit contenir un revêtement de surface (gravillon, sable, etc...) avec une capacité d'amortissement selon les normes CSA-Z614.          Sauf avis contraire.          Zone de protection <u>minimum</u> requise:          8.45m (27'8 11/16")          x          7.9 m (25'11")          - Surface: 65.08 sq. m (700.5' sq. ft.)          - Perimeter: 30.5m (100.2' ft)</p>	<p><b>PROTECTIVE SURFACING ZONE :</b>          Each equipment shall have a protective surfacing zone that consist of obstacle-free surfacing surrounding the equipment. This zone shall contain shock absorbing material (pea gravel, sand, etc...) that comply with CSA-Z614. Unless noted otherwise.          Minimum          Protective Surfacing Zone required:          8.45m (27'8 11/16")          x          7.9 m (25'11")          - Surface: 65.08 sq. m (700.5' sq. ft.)          - Perimeter: 30.5m (100.2' ft)</p>
<p><b>MÉTHODES D'INSTALLATION</b>          ①          DANS LE BÉTON:          - Quantité de Sonotube de 12" Ø x 12' :4          Béton:          -2.0m.cu.          (2.2vge.cu.)</p> 	<p><b>INSTALLATION METHODS</b>          ①          CONCRETE          -Quantity of sonotube of 12"Øx12':4          CONCRETE          -2.0 cu.m.          (2.2cu.yd.)</p> 
<p>②  <b>SYSTÈME AUTO-PORTANT:</b>          Qté charpentes: <b>NA</b>          Béton :          - 0 m. cu.          (0vge cu.)</p> 	<p>②  <b>FREE-STANDING SYSTEM:</b>          Frame QTY: <b>NA</b>          Concrete:          - 0 cu. m.          (-0 cu. yd.)</p> 
<p>Attention :  <b>AIRE DE CIRCULATION LIBRE:</b>          Aire dégagée d'obstacle qui se prolonge sur au moins 1.8m (70.87") au delà de la zone de protection. Voir dessin pour les détails.</p> 	<p>Warning:  <b>NO-ENCROACHMENT ZONE:</b>          Obstacle-free zone extending at least 1.8m (70.87") beyond the protective surfacing zone. See drawing for details.</p> 

<p><b>B_412-4</b></p>	<p>Min. Protective Surface Required / Surface de protection min. requise          7.9m (25'11") x 8.45m (27'8 11/16")</p>	<p>Equipment Dimensions / Dimensions de l'équipement :          4.8m (15'8 11/16") x 4.25m (13'11")</p>	<p>Fall Height /          Hauteur de chute:          1.31 m (4' 3 9/16")</p>	<p>Approval date: 2023-06-29          Rev: 00          Initial: OP</p>
<p>CAN/CSA-Z614</p>	<p>Recommended Ages / Âges recommandés :          5 years to 12 years old / 5ans à 12 ans</p>	<p>Capacity / Peut accueillir : up to          8 children / Jusqu'à 8 enfants</p>	<p>SHEET 4 OF 4</p>	