



23 ch. Boom Lane, Unit/Unité E, Industrial Park/Parc industriel
 Atholville, New-Brunswick, Canada, E3N 4E8
 Tel/tél. : 1-888-212-1411, Fax. : 1-888-789-0987
 contact@kangoroo.com / www.kangoroo.com

Colors / Couleurs

2 color HDPE/HDPE 2 couleurs:
 Brown & Tan/Brun et beige

Accent Color / Couleur complémentaire:
 Blue & Yellow/Bleu et jaune

Powder coating
 Poudre de polyester: Black/Noir

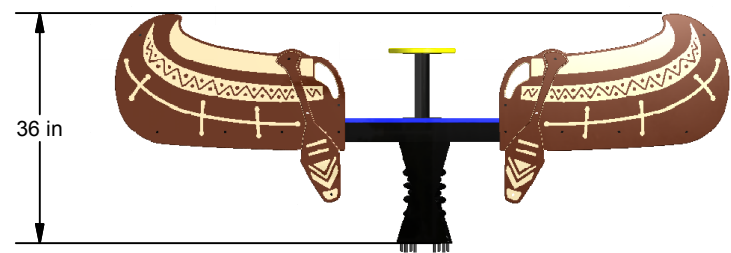
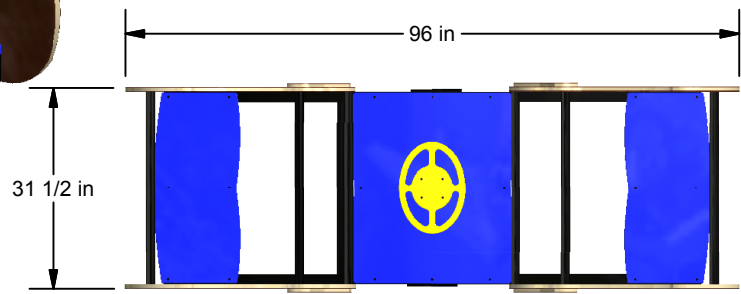
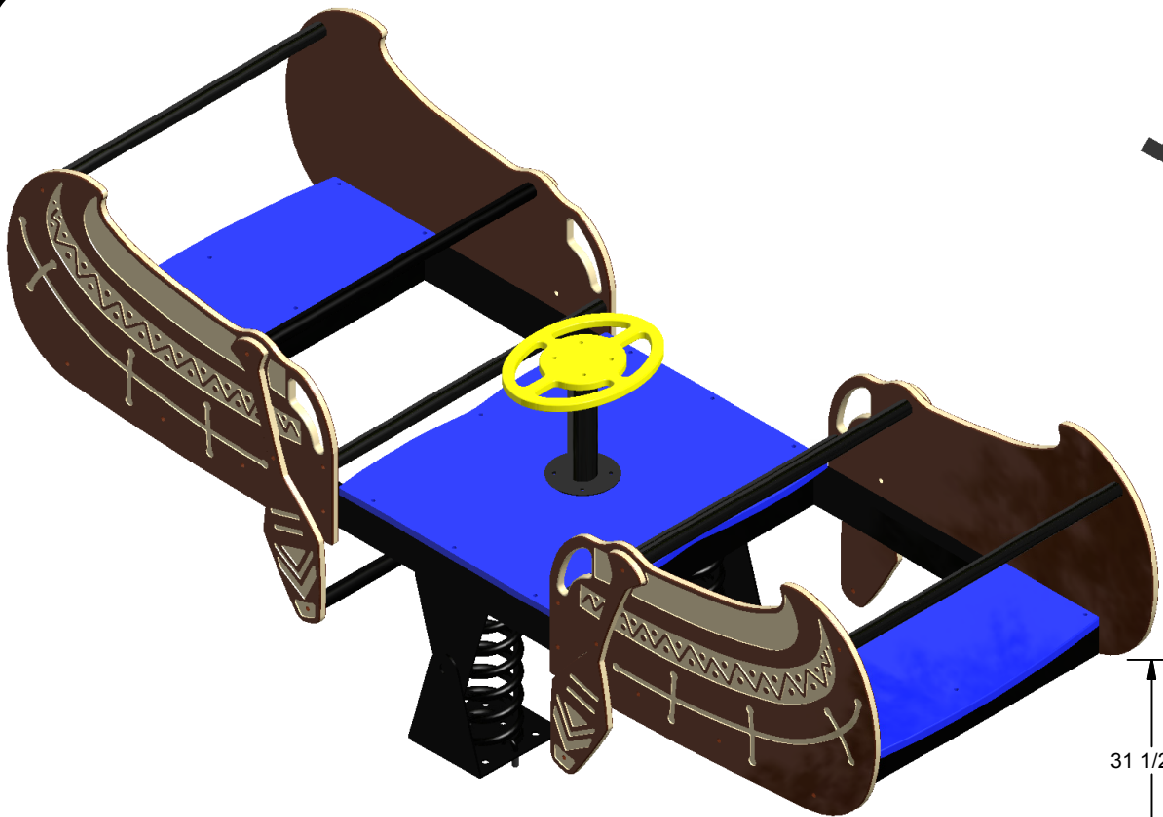

<p>B-418</p>	<p>Min. Protective Surface Required / Surface de protection min. requise : 6.1 m (20'-0") x 4.5 m (4'-9")</p>	<p>Equipment Dimensions / Dimensions de l'équipement : 2.4 m (8'-0") x 0.8 m (2'-9")</p>	<p>Approval date: 24/03/2020 Rev: 00 Initial: TLG</p>
<p>CAN/CSA-Z614-xx xx: Last Edition Published/ Dernière édition publiée</p>	<p>Recommended Ages / Âges recommandés : 18 months to 12 years old / 18 mois à 12 ans</p>	<p>Capacity / Peut accueillir : up to 8 children / Jusqu'à 8 enfants</p>	



23 ch. Boom Lane, Unit/Unité E, Industrial Park/Parc industriel
 Atholville, New/Nouveau-Brunswick
 Canada, E3N 4E8
 Tel/tél. : 1-888-212-1411 - Fax/télec. : 1-888-789-0987
 contact@kangoroo.com / www.kangoroo.com

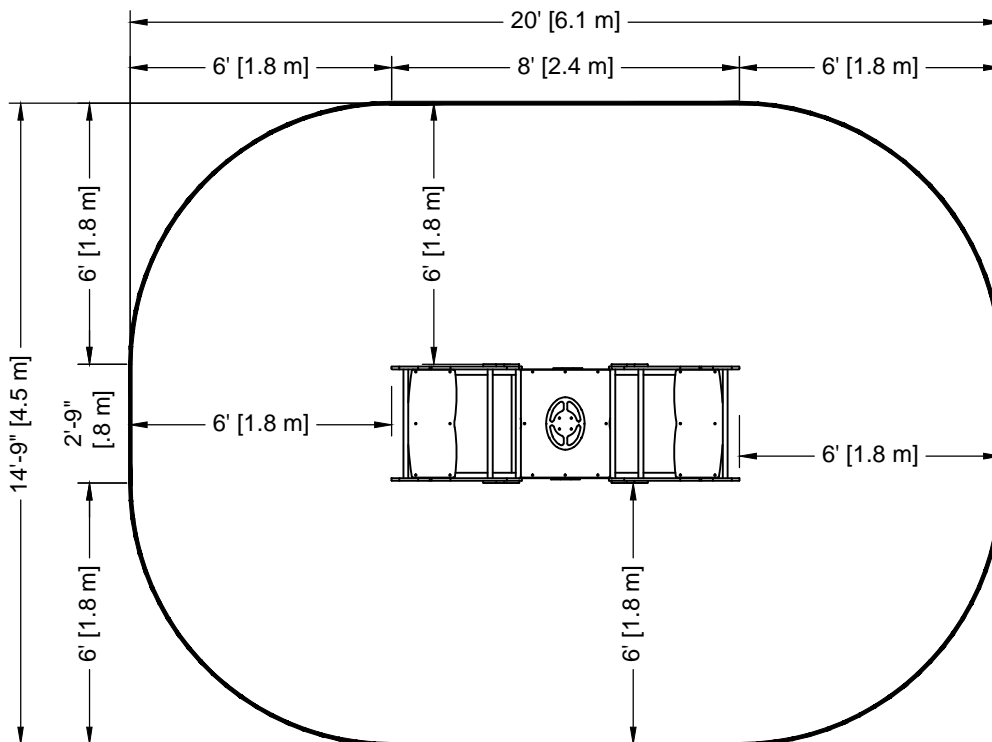

ZONE DE PROTECTION:

Chaque équipement doit avoir une zone de protection constituée d'une surface sans obstacle qui se prolonge dans toutes les directions à partir du périmètre de l'équipement. Cette zone doit contenir un revêtement de surface (gravillon, sable, etc...) avec une capacité d'amortissement selon les normes CSA-Z614. Sauf avis contraire.

Zone de protection minimum requise:

$$6.1 \text{ m (20'-0")}$$

$$\times$$

$$4.5 \text{ m (4'-9")}$$

- Aire : 24.49 m ca. (263.58 pi. ca.)
- Périmètre : 18.30 m (60'-0")

PROTECTIVE SURFACING ZONE :

Each equipment shall have a protective surfacing zone that consist of obstacle-free surfacing surrounding the equipment. This zone shall contain shock absorbing material (pea gravel, sand, etc...) that comply with CSA-Z614. Unless noted otherwise.

Minimum

Protective Surfacing Zone required:

$$6.1 \text{ m (20'-0")}$$

$$\times$$

$$4.5 \text{ m (4'-9")}$$

- Surface: 24.49 sq. m (263.58 sq. ft.)
- Perimeter: 18.30 m (60'-0")

MÉTHODES D'INSTALLATION

1

DANS LE BÉTON:

- Quantité de Sonotube de 12" Ø x 12' : 1

Béton :
 - 0.16 m. cu.
 (0.2 vge cu.)

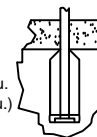

1

CONCRETE:

- Quantity of Sonotube of 12" Ø x 12' : 1

Concrete:
 - 0.16 cu. m.
 (0.2 cu. yd.)

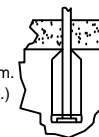

2

SYSTÈME AUTO-PORTANT:

Qté charpentes: 0

Béton :
 - NA m. cu.
 (NA vge cu.)



2

FREE-STANDING SYSTEM:

Frame QTY: 0

Concrete:
 - NA cu. m.
 (NA cu. yd.)



Attention :

AIRE DE CIRCULATION LIBRE:

Aire dégagée d'obstacle qui se prolonge sur au moins 1.8m (70.87") au delà de la zone de protection. Voir dessin pour les détails.

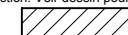

Warning:

NO-ENCROACHMENT ZONE :

Obstacle-free zone extending at least 1.8m (70.87") beyond the protective surfacing zone. See drawing for details.

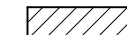

B-418

Equipment Dimensions / Dimensions de l'équipement :
 2.4 m (8'-0") x 0.8 m (2'-9")

Recommended Ages / Âges recommandés :
 18 months to 12 years old
 18 mois à 12 ans

CAN/CSA-Z614-xx
 xx: Last Edition Published /
 Dernière édition publiée

Capacity / Peut accueillir :
 up to 8 children / Jusqu'à 8 enfants

Fall Height /
 Hauteur de chute:
 0.79 m (2'-7")

Approval date: 24-03-2020
 Rev: 00
 Initial: TLG

