

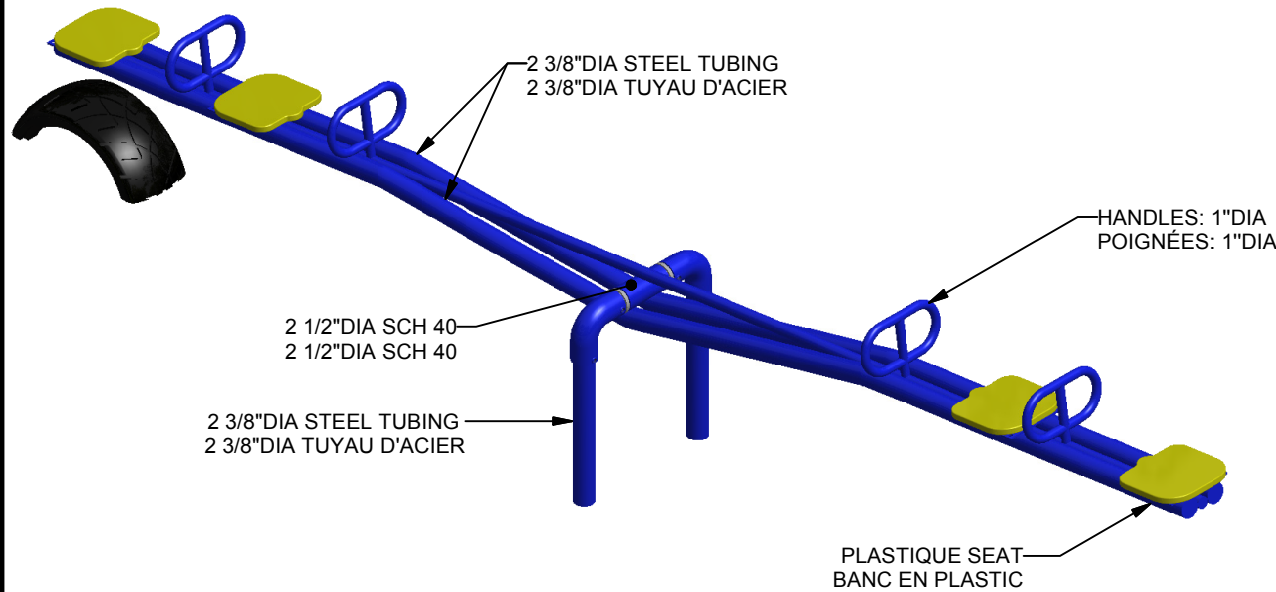

23 ch. Boom Lane, Unit/Unité E
 Industrial Park/Parc industriel
 Atholville, New/Nouveau-Brunswick
 Canada, E3N 4E8
 Tel/tél. : 1-888-212-1411/Fax/télec. : 1-888-789-0987
 contact@kangoroo.com / www.kangoroo.com

Colors / Couleurs

Blue & Yellow
 Bleu et jaune



MATERIAL SPECIFICATION / SPÉCIFICATION DU MATÉRIEL	
MATERIAL / MATÉRIEL	SPECIFICATION / SPÉCIFICATION
STEEL / ACIER	- COVERED WITH A POLYESTER POWDER PAINT. / COUVERT D'UNE PEINTURE DE POUDRE DE POLYESTER.
ALUMINUM / ALUMINIUM	COVERED WITH A POLYESTER POWDER PAINT. / COUVERT D'UNE PEINTURE DE POUDRE DE POLYESTER.
PLASTIC / PLASTIQUE	POLYETHYLENE RESIN WITH UV STABILIZER / RESIN DE POLYETHYLENE AVEC STABILISATEUR UV
	UNLESS NOTED OTHERWISE / SAUF AVIS CONTRAIRE

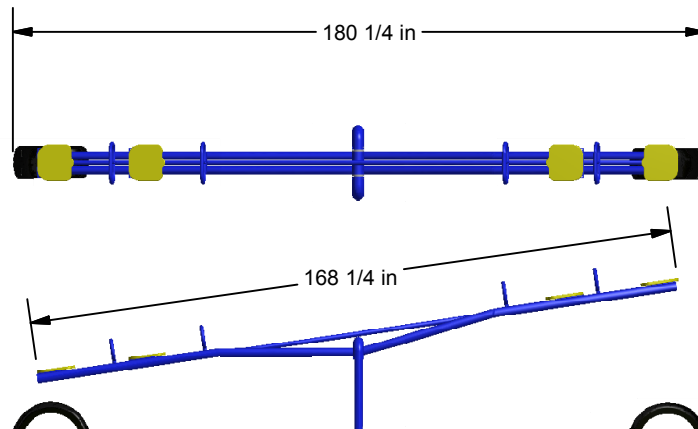

SHOCK ABSORBING MATERIAL REQUIRED BY CSA CODE:
 EX: AUTOMOBILE TIRES
 AMORTISSEUR REQUIS PAR LA NORME CSA:
 EX: PNEU D'AUTOMOBILE
 NOT INCLUDED / PAS INCLUS

B-407	Min. Protective Surface Required / Surface de protection min. requise : 8.2 m (27'-0") x 4.4 m (14'-3")	Equipment Dimensions / Dimensions de l'équipement : 4.2 m (13'-11") x 0.7 m (2'-3")	Approval date: 14/10/2016 Rev: 02 Initial: TLG
CAN/CSA-Z614-xx xx: Last Edition Published/ Dernière édition publiée	Recommended Ages / Âges recommandés : 5 to 12 years old / 5 à 12 ans	Capacity / Peut accueillir : up to 4 children / Jusqu'à 4 enfants	



23 ch. Boom Lane, Unit/Unité E, Industrial Park/Parc industriel
 Atholville, New/Nouveau-Brunswick
 Canada, E3N 4E8
 Tel/tél. : 1-888-212-1411 - Fax/télec. : 1-888-789-0987
 contact@kangoroo.com / www.kangoroo.com

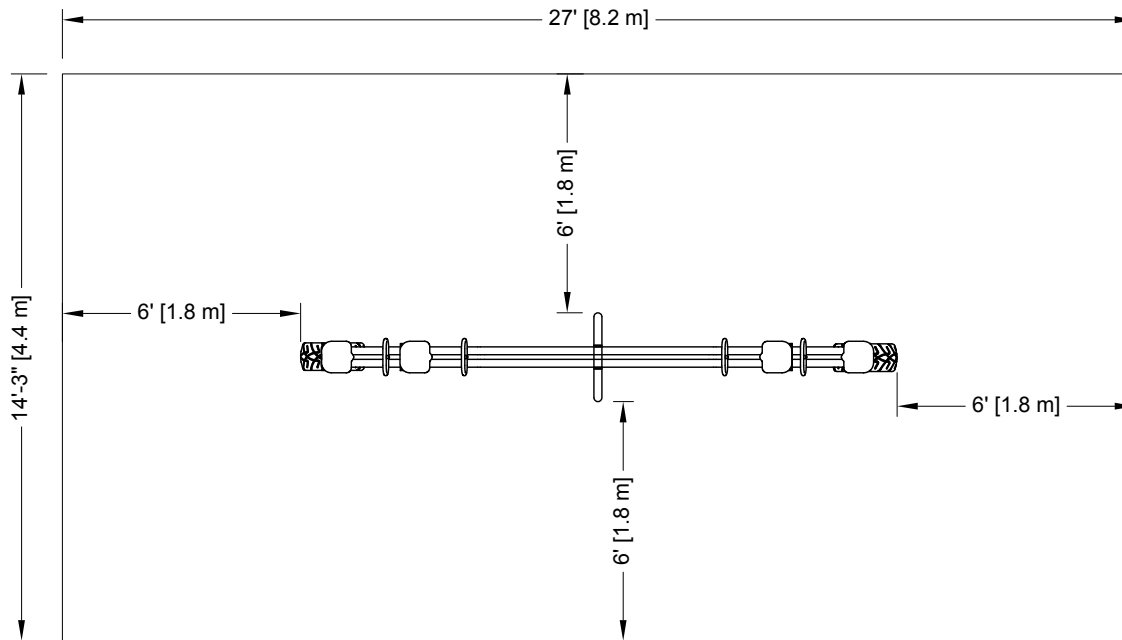

ZONE DE PROTECTION:

Chaque équipement doit avoir une zone de protection constituée d'une surface sans obstacle qui se prolonge dans toutes les directions à partir du périmètre de l'équipement. Cette zone doit contenir un revêtement de surface (gravillon, sable, etc...) avec une capacité d'amortissement selon les normes CSA-Z614. Sauf avis contraire.

Zone de protection minimum requise:

8.2 m (27'-0")
 x
 4.4 m (14'-3")

- Aire : 35.83 m ca. (385.79 pi. ca.)
- Périmètre : 25.30 m (83'-0")

PROTECTIVE SURFACING ZONE :

Each equipment shall have a protective surfacing zone that consist of obstacle-free surfacing surrounding the equipment. This zone shall contain shock absorbing material (pea gravel, sand, etc...) that comply with CSA-Z614. Unless noted otherwise.

Minimum

Protective Surfacing Zone required:

8.2 m (27'-0")
 x
 4.4 m (14'-3")

- Surface: 35.83 sq. m (385.79 sq. ft.)
- Perimeter: 25.30 m (83'-0")

MÉTHODES D'INSTALLATION

INSTALLATION METHODES

1

DANS LE BÉTON:

- Quantité de Sonotube de 12" Ø x 12" : 1

Béton :
 - 0.152 m. cu. (0.2 vge cu.)

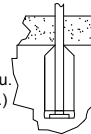

1

CONCRETE:

- Quantity of Sonotube of 12" Ø x 12": 1

Concrete:
 - 0.152 cu. m (0.2 cu. yd.)

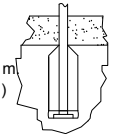

2

SYSTÈME AUTO-PORTANT:

Qté charpentes: **0**
 Béton :
 - NA m. cu. (NA vge cu.)



2

FREE-STANDING SYSTEM

Frame QTY: **0**
 Concrete:
 - NA cu. m. (NA cu. yd.)



Attention :

AIRE DE CIRCULATION LIBRE:

Aire dégagée d'obstacle qui se prolonge sur au moins 1.8m (70.87") au delà de la zone de protection. Voir dessin pour les détails.

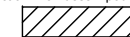

Warning:

NO-ENCROACHMENT ZONE

Obstacle-free zone extending at least 1.8m (70.87") beyond the protective surfacing zone. See drawing for details.



B-407

Equipment Dimensions / Dimensions de l'équipement :
 4.2 m (13'-11") x 0.7 m (2'-3")

Recommended Ages / Âges recommandés :
 5 to 12 years old
 5 à 12 ans

CAN/CSA-Z614-xx
 xx: Last Edition Published /
 Dernière édition publiée

Capacity / Peut accueillir :
 up to 4 children / Jusqu'à 4 enfants

Fall Height /
 Hauteur de chute:
 1.52 m (5'-0")

Approval date: 14-10-2016
 Rev: 02
 Initial: TLG

