

23 ch. Boom Lane, Unit/Unité E  
 Industrial Park/Parc industriel  
 Atholville, New/Nouveau-Brunswick  
 Canada, E3N 4E8  
 Tel/tél. : 1-888-212-1411/Fax/télééc. : 1-888-789-0987  
 www.kangaroo.com

ALL STEEL IS PRE-GALVANISED  
 COVERED WITH A POLYESTER  
 POWDER PAINT. /  
 TOUT ACIER EST PRÉ-GALVANISÉ ET  
 COUVERT  
 D'UNE PEINTURE DE POUDRE DE  
 POLYESTER.

SEAT: -HIGH DENSITY POLYETHYLENE  
 -U.V. STABILISED  
 BANC: -PLASTIQUE POLYETHYLENE  
 -STABILISATEUR U.V.

SHOCK ABSORBING MATERIAL REQUIRED BY CSA CODE:  
 EX: AUTOMOBILE TIRES  
 AMORTISSEUR REQUIS PAR LA NORME CSA:  
 EX: PNEU D'AUTOMOBILE  
 NOT INCLUDED / PAS INCLUS

<b>B-403</b>	Min. Protective Surface Required / Surface de protection min. requise : 7.9 m (25'-11") x 4 m (13'-1")	Equipment Dimensions / Dimensions de l'équipement : 3.04 m (10'-0") x 0.254 m (0'-10")	Approval date: 2008-12-16 Rev: 00
CAN/CSA-Z614	Recommended Ages / Âges recommandés : 5 to 12 years old / 5 à 12 ans	Capacity / Peut accueillir : up to 2 children / Jusqu'à 2 enfants	Initial: TLG



23 ch. Boom Lane, Unit/Unité E  
 Industrial Park/Parc industriel  
 Atholville, New/Nouveau-Brunswick  
 Canada, E3N 4E8  
 Tel/tél. : 1-888-212-1411/Fax/télec. : 1-888-789-0987  
 www.kangaroo.com

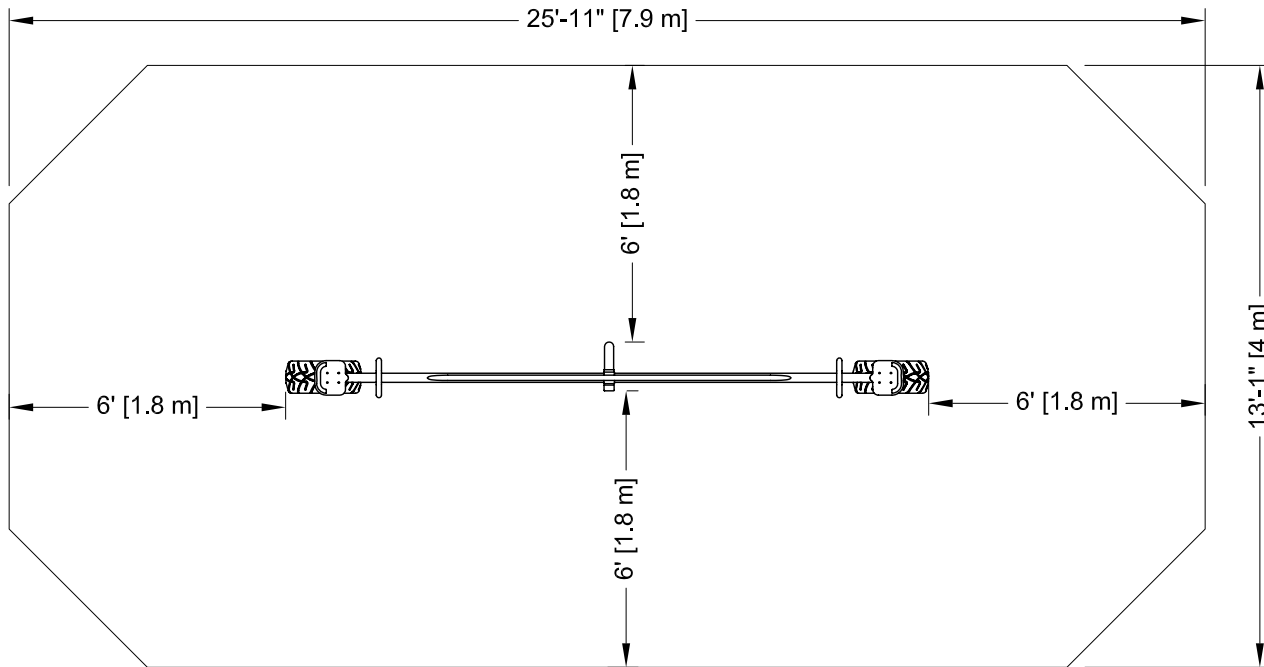

**SURFACE DE PROTECTION**

Attention :  
 Une aire de protection est requise dessous et autour de la structure de jeu.

Légende :

Aire de protection

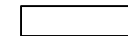

Aire de circulation libre



Asphalte

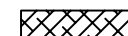

Aire de protection recommandée :

- Aire : 29.61 m ca. (318.75 pi. ca.)
- Quantité : 2.75 vge cu. (9.03 m cu.) pour 305 mm (12") d'épaisseur.

Sonotube de 12" Ø x 12' :

- Quantité : 1

Ciment :

- .1 vge cu.

**PROTECTIVE SURFACE**

Warning:  
 A protective area is required under and around the play structure.

Legend:

Protective Surface

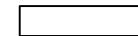

No-Encroachment Zone



Asphalt



Recommended Protective Surface:

- Surface: 29.61 sq. m (318.75 sq. ft.)
- Quantity: 2.75 cu. yd. (9.03 cu. m) for 305 mm (12") thickness.

Sonotube of 12" Ø x 12' :

- Quantity: 1

Concrete:

- .1 cu. yd.

**B-403**

Min. Protective Surface Required / Surface de protection min. requise :  
 7.9 m (25'-11") x 4 m (13'-1")

Equipment Dimensions / Dimensions de l'équipement :  
 3 m (10'-0") x 0.254 m (0'-10")

Approval date: 16/12/2008  
 Rev: 00  
 Initial: TLG

CAN/CSA-Z614

Recommended Ages / Âges recommandés :  
 5 to 12 years old / 5 à 12 ans

Capacity / Peut accueillir :  
 up to 2 children / Jusqu'à 2 enfants