



23 ch. Boom Lane, Unit/Unité E, Industrial Park/Parc industriel  
 Atholville, New-Brunswick, Canada, E3N 4E8  
 Tel/tél. : 1-888-212-1411, Fax. : 1-888-789-0987  
 contact@kangoroo.com / www.kangoroo.com





**Colors / Couleurs**

Post / Poteaux: CYAN/CYAN

Accent Color / Couleur complémentaire:  
 SAFFRON GOLD/SAFRAN DORÉ

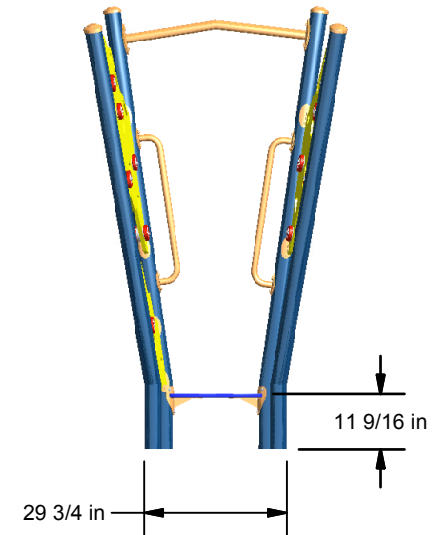
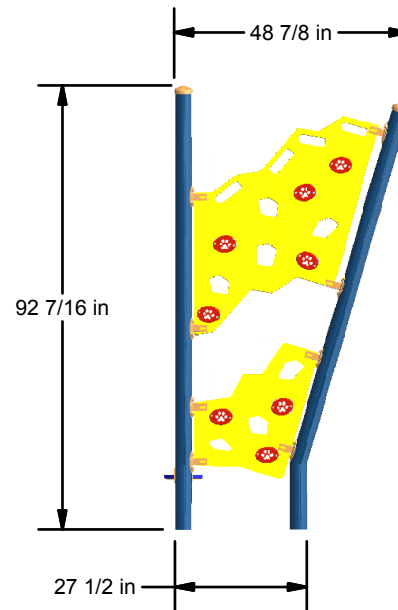
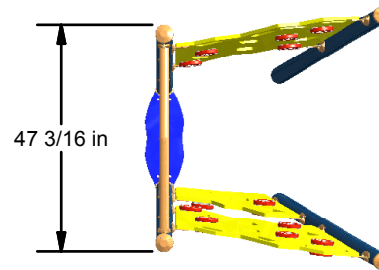
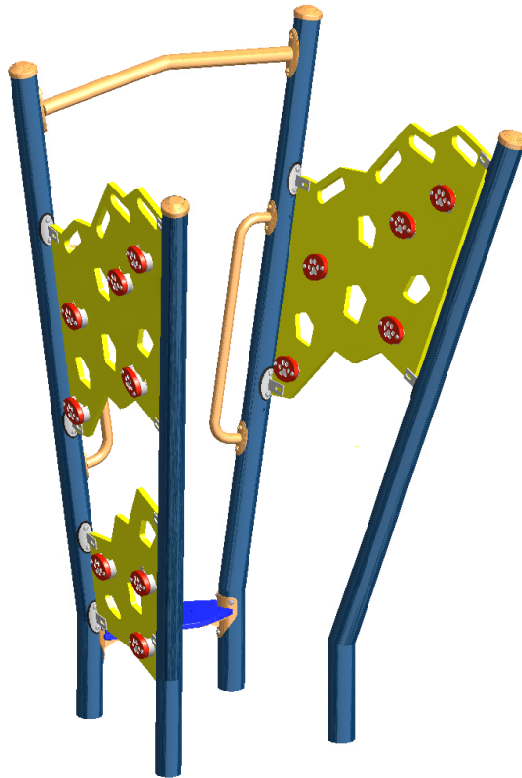
HDPE Panel / Panneaux HDPE: YELLOW/JAUNE



|   |   |   |   |
|---|---|---|---|
| <p><b>3D-PUZ-100</b></p>  | <p>Min. Protective Surface Required / Surface de protection min. requise :<br/>         5.0 m (16'-3") x 5.1 m (16'-7")</p> | <p>Equipment Dimensions / Dimensions de l'équipement :<br/>         1.3 m (4'-3") x 1.4 m (4'-7")</p> | <p>Approval date: 31/10/2019<br/>         Rev: 00<br/>         Initial: TLG</p>       |
| <p>CAN/CSA-Z614-xx<br/>         xx: Last Edition Published/<br/>         Dernière édition publiée</p> | <p>Recommended Ages / Âges recommandés :<br/>         5 to 12 years old / 5 à 12 ans</p>                                    | <p>Capacity / Peut accueillir :<br/>         up to 6 children / Jusqu'à 6 enfants</p>                 |  |

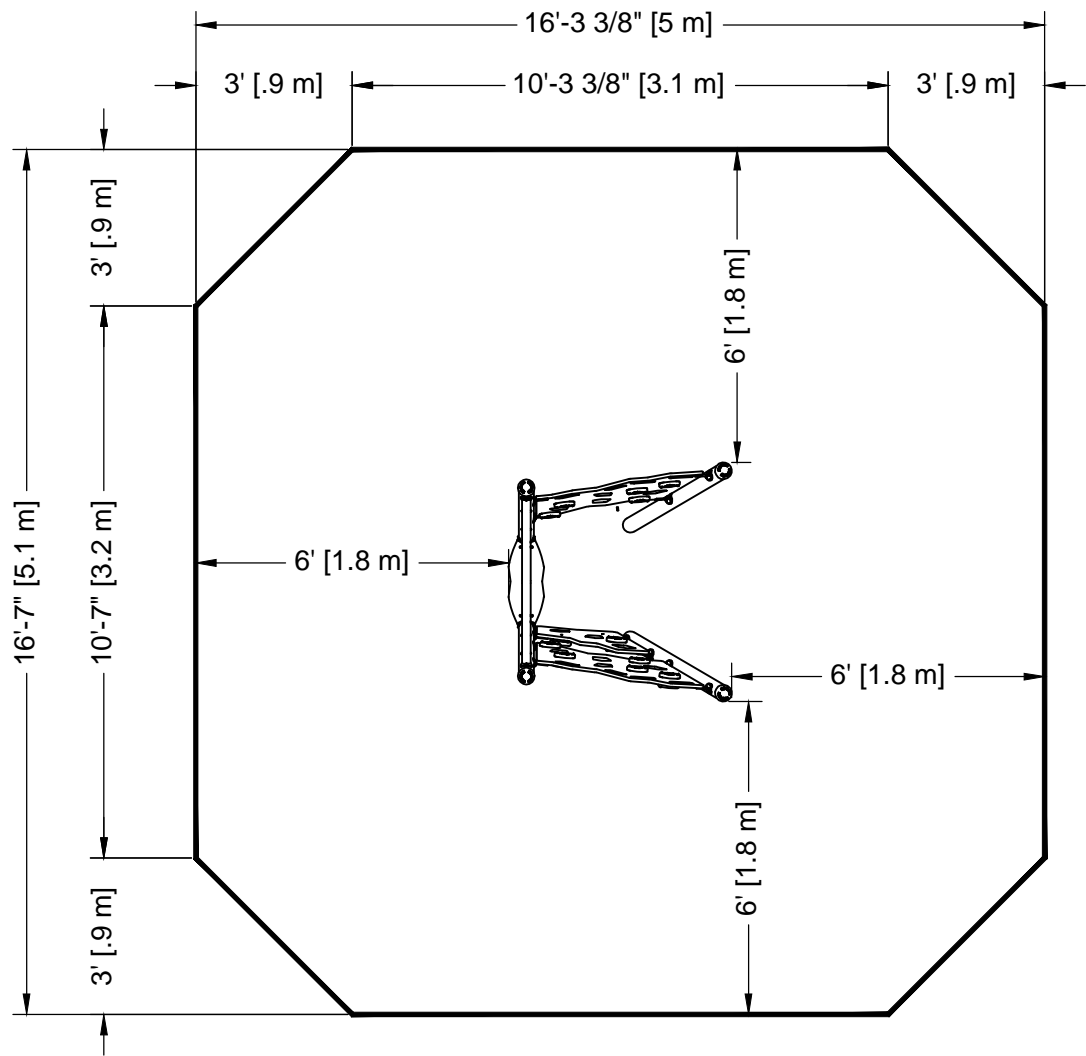

23 ch. Boom Lane, Unit/Unité E, Industrial Park/Parc industriel  
 Atholville, New/Nouveau-Brunswick  
 Canada, E3N 4E8  
 Tel/tél. : 1-888-212-1411 - Fax/télec. : 1-888-779-0987  
 contact@kangoroo.com / www.kangoroo.com

**ZONE DE PROTECTION:**

Chaque équipement doit avoir une zone de protection constituée d'une surface sans obstacle qui se prolonge dans toutes les directions à partir du périmètre de l'équipement. Cette zone doit contenir un revêtement de surface (gravillon, sable, etc...) avec une capacité d'amortissement selon les normes CSA-Z614. Sauf avis contraire.

**Zone de protection minimum requise:**

5.0 m (16'-3")  
 x  
 5.1 m (16'-7")

- Aire : 23.42 m ca.  
 (252.03 pi. ca.)  
 - Périmètre : 17.98 m  
 (59'-0")

**PROTECTIVE SURFACING ZONE :**

Each equipment shall have a protective surfacing zone that consist of obstacle-free surfacing surrounding the equipment. This zone shall contain shock absorbing material (pea gravel, sand, etc...) that comply with CSA-Z614. Unless noted otherwise.

**Minimum Protective Surfacing Zone required:**

5.0 m (16'-3")  
 x  
 5.1 m (16'-7")

- Surface: 23.42 sq. m  
 (252.03 sq. ft.)  
 - Perimeter: 17.98 m  
 (59'-0")

**MÉTHODES D'INSTALLATION**

①

**DANS LE BÉTON:**

- Quantité de Sonotube de 12" Ø x 12" : 1

Béton :  
 - 0.31 m. cu.  
 ( 0.4 vge cu.)



①

**CONCRETE:**

- Quantity of Sonotube of 12" Ø x 12" : 1

Concrete:  
 - 0.31 cu. m.  
 (0.4 cu. yd.)

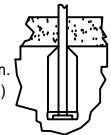

②

**SYSTÈME AUTO-PORTANT:**

Qté charpentes: **NA**  
 Béton :  
 - NA m. cu.  
 (NA vge cu.)



②

**FREE-STANDING SYSTEM:**

Frame QTY: **NA**  
 Concrete:  
 - NA cu. m.  
 (NA cu. yd.)



**Attention :**

**AIRE DE CIRCULATION LIBRE:**

Aire dégagée d'obstacle qui se prolonge sur au moins 1.8m (70.87") au delà de la zone de protection. Voir dessin pour les détails.

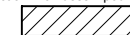

**Warning:**

**NO-ENCROACHMENT ZONE :**

Obstacle-free zone extending at least 1.8m (70.87") beyond the protective surfacing zone. See drawing for details.



**3D-Puz-100**

Equipment Dimensions / Dimensions de l'équipement :  
 1.3 m (4'-3") x 1.4 m (4'-7")

Recommended Ages / Âges recommandés :  
 5 to 12 years old  
 5 à 12 ans

Fall Height /  
 Hauteur de chute:  
 2.44 m (8'-0")

Approval date: 31-10-2019  
 Rev: 00  
 Initial: TLG



CAN/CSA-Z614-xx  
 xx: Last Edition Published /  
 Dernière édition publiée

Capacity / Peut accueillir :  
 up to 6 children / Jusqu'à 6 enfants