

REDRAILED

SKATEBOARD STRUCTURES



A division of



TERRAINS DE JEUX
KANGOROO
PLAYGROUNDS



The Redrailed line of skateboard ramps and accessories is a product manufactured and designed by Kan-Go-Roo Playgrounds Ltd. Kan-Go-Roo has grown from its humble begins into a world class manufacturer of playground, recreational, and sport equipment. With continuous innovation, dedication to manufacturing quality products and determination to continuously strive for improvement, Kan-Go-Roo has emerged as a leader in playground, sport and recreation design and safety.

ISO 9001 (2008) Certified

Kan-Go-Roo has the distinction of a being an ISO 9001 (2008) certified company. What this means is that Kan-Go-Roo has a systematic process of manufacturing and designing products with the ultimate goal of customer satisfaction. Product design and manufacturing processes are strictly followed with ISO 9001 (2008) certified process of manufacturing. This means that the products manufactured have had extra care and effort put into their manufacturing resulting in a superior finished product.



CWB (Certified)

The CWB Group is dedicated to the enhancement of public safety and the success of our clients through the provision of welding certification, management systems registration and educational services.



ASTM F2334

We follow their safety standard guide for above ground public use skatepark facilities All products manufactured will be in conformity to Ff2334 standards



Kangaroo Playground Ltd is proud of their relationship with their clients, old or new. The quality of the service and the high standards of the manufacturing process makes us one of the leading equipment manufacturer in Canada

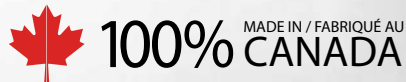

The sport of skateboarding may have been discovered on the sunny beaches of California, but Kan-Go-Roo has designed, manufactured and perfected a series of skateboard ramps and accessories that will endure the harsh Canadian climate.

Why Aluminum?

Aluminum has a unique characteristic that gives it the benefit of excellent corrosion resistance. An oxide film, bonded strongly to the surface of aluminum, forms to protect it from corrosion. If damaged, this film reforms almost immediately to protect the surface from corroding in most environments. With an all aluminum surface, RedRailed ramps are suited to withstand everyday use in almost any climate. We use Aluminum 5052 H32 for our product surfacing and skirting because this alloy is known for its high corrosion resistance along with its strength. For the frame of our products, we use Aluminum 6061-T6 because of its high strength characteristics and very good corrosion resistance.

Safety Smooth Surface:

RedRailed ramps have been designed to allow for a safe smooth riding surface. The riding surface is welded to the frame from underneath. This measure ensures that the surface is free of bolts from backing out. This feature also reduces the amount of maintenance required since you do not have to adjust bolts or rivets that have come loose.

Super Solid Frames

Our frames are made from aluminum angles and square tubing. This allows for a very durable frame which is lightweight when compared to steel, or concrete. An aluminum frame helps reduce the overall weight of the structure making it easier to move for winter storage or reconfigurations for new riding challenges and flow design.

Hand and Deck Rails

Our railings are manufactured from Allied playground quality steel that contains no heavy metals. Our railings are also powder coated with a TGIC free powder coating good for the environment and does not contain any lead.

Aluminum Frame and Surfacing ✓

Light Weight Easy to Move ✓

Equipment Preassembled ✓

Manufactured in Canada (NAFTA) ✓

Surfacing Welded to Frame ✓

Galvanised Steel Ramp Railing ✓

Fully Skirted Ramps, Banks ✓

Virtually Maintenance Free ✓

Powder coated Railing ✓

Ramp Skirting

Our ramps are fully skirted with aluminum sheets to avoid vandalism and tampering. The porous nature of the aluminum skirting also allows for the dampening of sound and by helping to contain the sound within the structure.

Installation and Maintenance

Our ramps are virtually maintenance free however we have included a simple maintenance manual to help maintain your ramps. Our ramps also come preassembled when possible making them very easy to install.



RAILS

Powder Coated TGIC Free
Allied Steel Tubing



SMOOTH SUR- FACE

Fabricated with 0.188" thick
Aluminum 5052 H32 sheet

FRAME

Fabricated with Aluminum 6061-T6
square tubing (1" x 1" x 0.12")
with Al 6061-T6 angle supports (1.5" x
1.5" x 0.188") spaced 10" – 12" apart

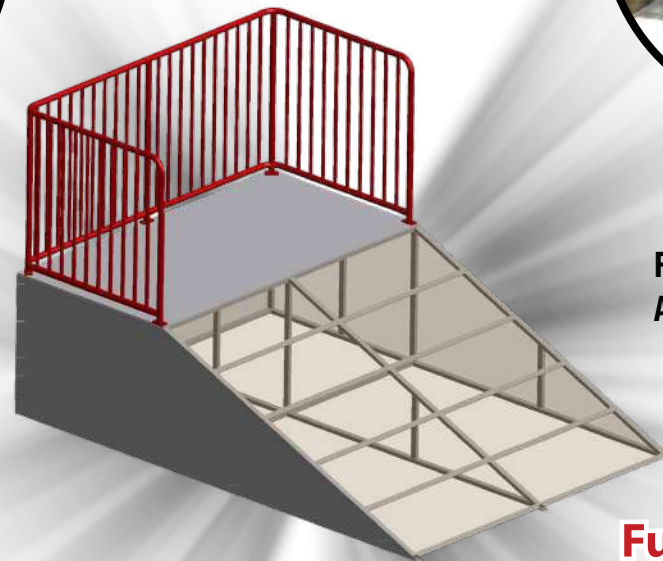
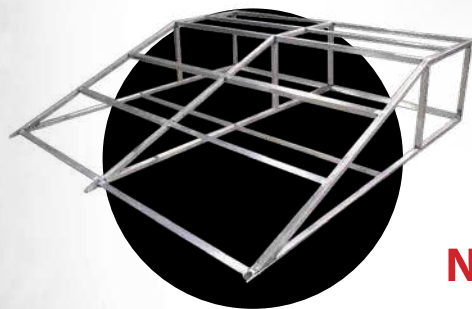

Fully Skirted

Fully skirted with 0.056" thick
Aluminum 5052 H32



Noise Reduction

Further reduce the decibel level
of your ramps with optional sound
proofing materials.

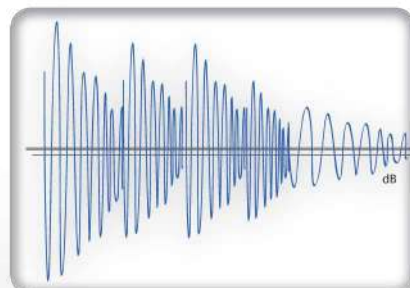

Safety Standards

- All products manufactured will be in conformity to
ASTM WK614
ASTM F2334
ASTM F2698
BS EN 14974:2006

Manufacturing Method (ISO 9001- 2008)

- Manufactured in an ISO 9001 (2008) Certified Company
- Lean Manufacturer
- CWB Certified (Canadian Welding Bureau)
- Equipment comes preassembled and packaged
- Product manufactured in Canada and is compliant to (NAFTA)
- Surfacing is attached by welding surface to the frame. This method eliminates surface bolts and creates a safe smooth riding surface

Surfacing and Frame

- Fabricated with Aluminum 6061-T6 square tubing (1.5" X 1.5" X .120 inch)
- Surface – 3/16 inch aluminium sheet
- All support members and ramp to be welded into one piece
- Coping to be constructed from 2" diameter aluminum tubing
- Transition area from ramp to ground is one continuous piece IE: The surfacing acts as the transition area
- All Accessories are fully skirted

Rails

- Fabricated with 1.375" diameter powder coated pre-galvanized Allied steel tubing
- The rails are attached with zinc-plated or stainless steel fasteners
- Rails to be powder coated with non toxic TGIC free paint

* For more detailed information on our specifications please contact us: 1-888-212-1411



WARRANTY

15 Year

Limited Warranty against structural failure caused by defects in materials or manufacturing.

5 Year

Limited warranty on Aluminum surface against structural failure caused by defects in materials or manufacturing.

1 Year

Kan-Go-Roo Playgrounds warrants that all product or equipment will be free from defects in materials or workmanship for one year.

* The warranties do not cover damage caused by vandalism or abuse. This warranty does not include cosmetic issues such as color fading, do not cover wear and tear from normal use and surface corrosion on metal parts. The warranties do not cover cost of freight and/or installation. It is valid if the structure and/or equipment are erected to conform with Kan-Go-Roo Playgrounds Ltd. installation instructions and maintained according to the maintenance procedures furnished by Kan-Go-Roo Playgrounds Ltd.

For a complete copy of the warranty please contact your Redrailed Representative

Mini HALF PIPES

Mini Half Pipe

The mini half pipe or half pipe is on every rider's list. It enables the rider to maintain speed in order to execute multiple tricks. The half pipe and mini half pipe are constructed with two quarter pipes flat bottom, and are available in various heights and sizes and are fully skirted



Half Pipe	Available Dimensions		
Product #	L	W	H
RedR-HP3	27'	7'-6"	3'
RedR-HP4	28'	7'-6"	4'



Mini HALF PIPES Modified

Mini Half Pipe Modified

Expand the possibilities of your mini half pipe by adding a quarter pipe or bank. The additional quarter pipe or bank can be attached at various angles making for some interesting possibilities.

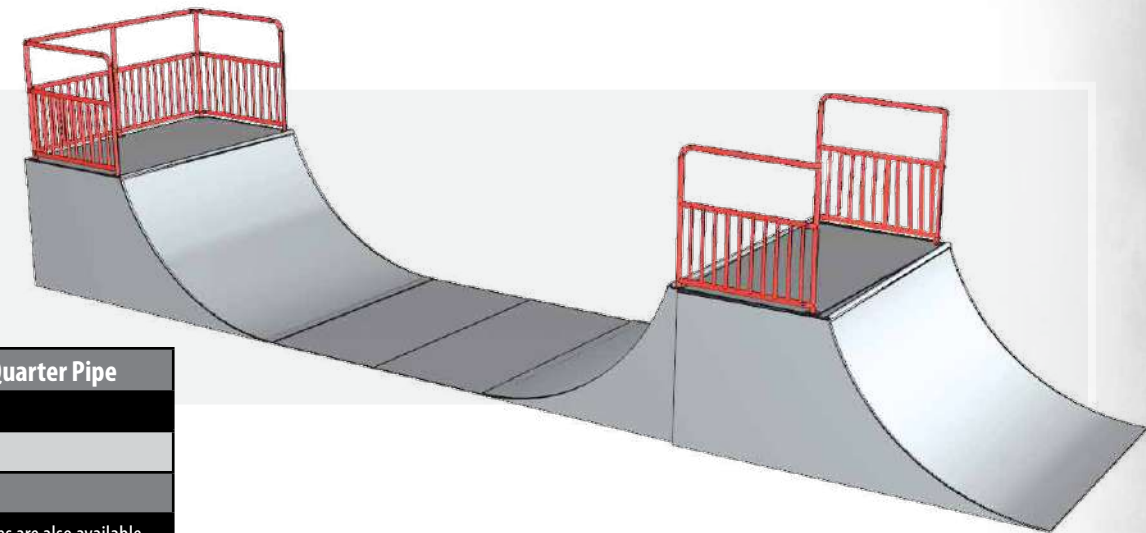

Mini Half Pipe with Hip Quarter Pipe
Additions
Quarter Pipe
Half pipe
Custom sizes are also available

Half Pipe	Available Dimensions		
Product #	L	W	H
RedR-HP3-2	27"	15'	3'
RedR-HP4-2	28'	15'	4'
RedR-HP5-2	29'	15'	5'

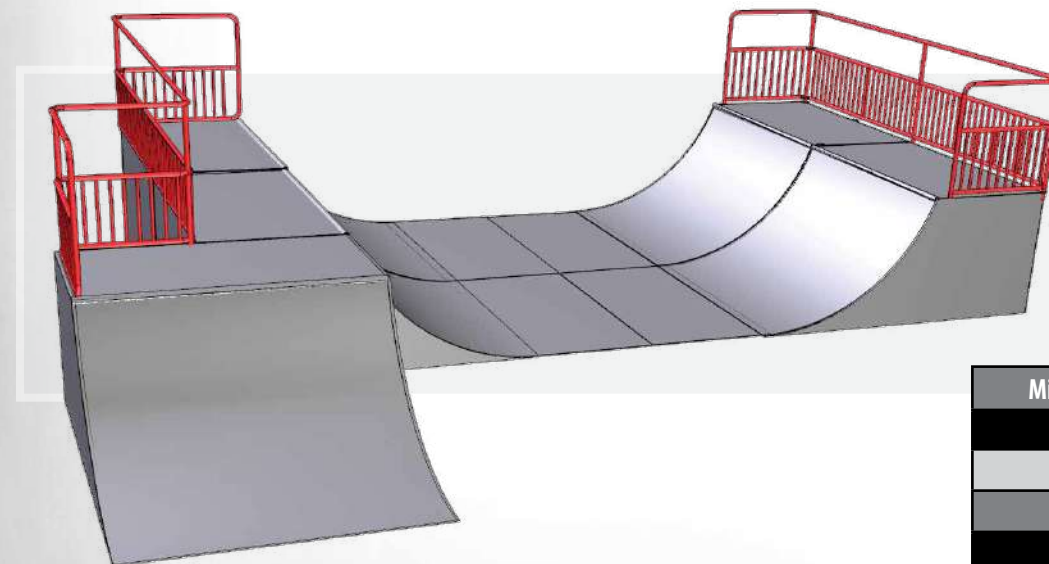
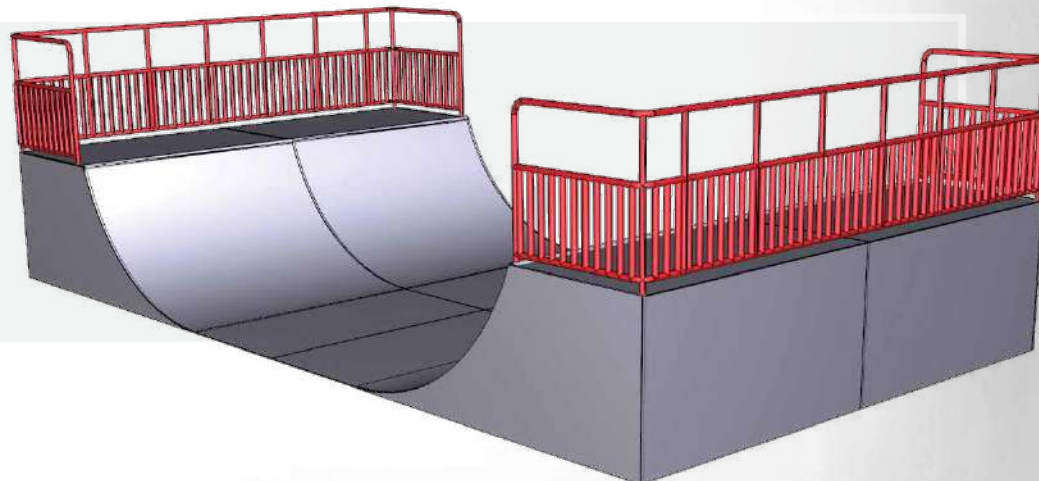

Mini Half Pipe with Hip Quarter Pipe
Additions
Quarter Pipe
Half pipe
Custom sizes are also available

Quarter Pipes

The quarter pipe is an essential piece of equipment that helps keep the flow of the skate-park. Very similar in design to the bank however the riding surface of the quarter pipe is curved. Riders use the quarter pipe by riding up to perform a trick then ride down. It also helps keep the momentum when riding down in order to reach other pieces of equipment in the skatepark.



Quarter Pipe	Available Dimensions		
Product #	L	W	H
RedR-QP3	9' - 4"	7' - 6"	3'
RedR-QP4	9' - 7"	7' - 6"	4'
RedR-QP5	9' - 10"	7' - 6"	5'

Banks

Often used as the starting point for many riders. Usually placed on the edges of the skate park the banks enable the rider to get some momentum in order to perform some tricks on other pieces of equipment. Similar in design to the quarter pipe, however the bank riding surface is not curved.



Banks	Available Dimensions		
Product #	L	W	H
RedR-B3	10'	7'6"	3'
RedR-B4	12'	7'6"	4'
RedR-B5	14'	7'6"	5'

Quarter Pipe (2X)	Available Dimensions		
Product #	L	W	H
RedR-QP3-2	9' - 4"	15'	3'
RedR-QP4-2	9' - 7"	15'	4'
RedR-QP5-2	9' - 10"	15'	5'



Bank (2X)	Available Dimensions		
Product #	L	W	H
RedR-B3-2	10'	15'	3'
RedR-B4-2	12'	15'	4'
RedR-B5-2	14'	15'	5'



QUARTER PIPES & Bank Combinations

BANK TO BANKS & MODULE

Quarter Pipe and Bank Combo

Combining a quarter pipe and bank can offer a new ridding opportunities. No only can a rider choose between a quarter or bank in relatively the same space, but combining the two components also help save space.

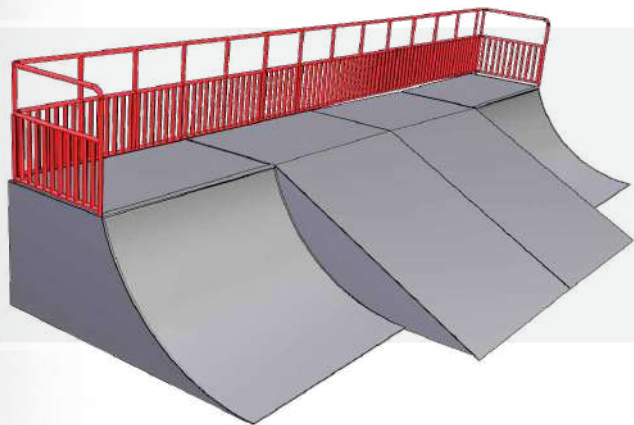

Quarter Pipe Bank Combo	Available Dimensions		
Product #	L	W	H
RedR-Mod2-3	27' - 4"	10'	3'
RedR-Mod2-4	27' - 4"	12'	4'
RedR-Mod2-5	27' - 4"	14'	5'

Quarter Pipe Bank Combo	Available Dimensions		
Product #	L	W	H
RedR-Mod3-3	27' - 4"	14'	3'
RedR-Mod3-4	27' - 4"	16'	4'

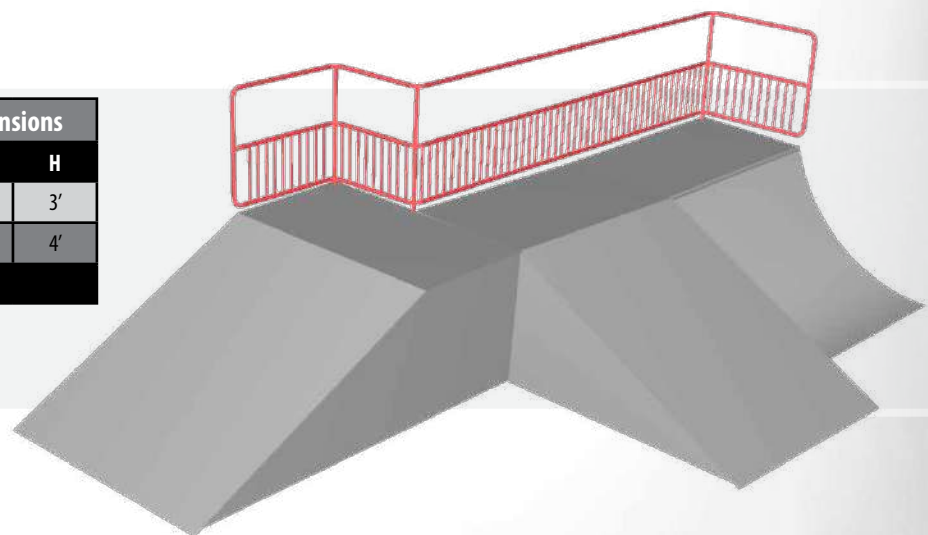

Bank to Bank

Banks to banks offer a wide variety of options; their modular design enables them to be modified in order to achieve what challenges the rider is looking for. The bank to banks are constructed from two banks, obstacles and accessories such as stairs, grind rails, and/or grind boxes.

Product #	L	W	H	Features
RedR-BB101	16'	7' - 6"	2'	Grind Rail
Custom sizes are also available				

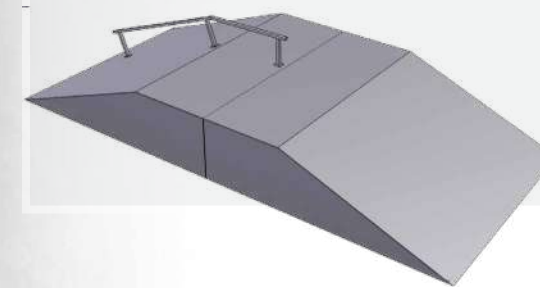

Product #	L	W	H	Features
RedR-BB102	18'	10'	2'	Grind Ledge & Rail
Custom sizes are also available				

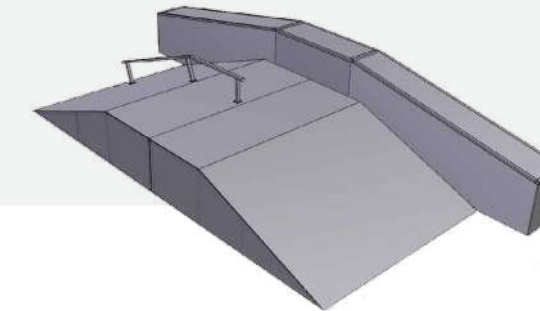

Product #	L	W	H	Features
RedR-BB103	14'	10'	2'	Stairs and Grind Ledge
Custom sizes are also available				

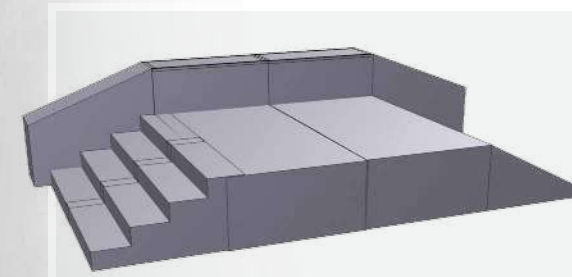

Product #	L	W	H	Features
RedR-BB104	16'	16'	2'	Grind Rail 4 way
Custom sizes are also available				

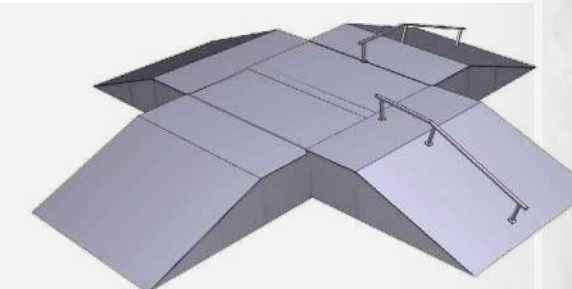

Product #	L	W	H	Features
RedR-BB100	16'	9'	2'	Stairs and Grind Rail
Custom sizes are also available				

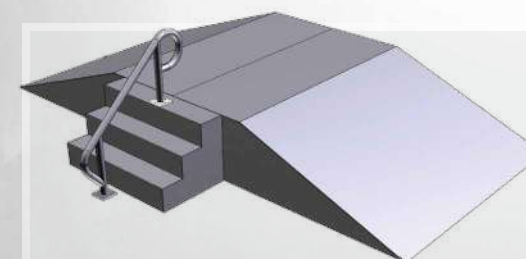

Product #	L	W	H	Features
RedR-BB106	16'	4'	2'	Grind Rail
Custom sizes are also available				

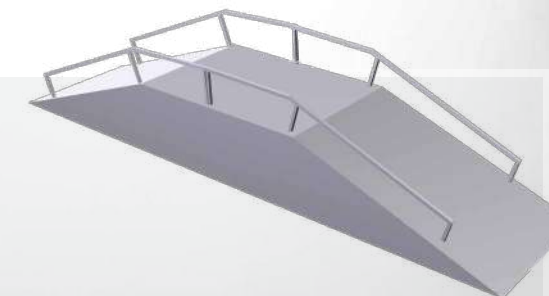

Combo Modules

Get creative and create your own unique skatepark component. Redrailed offers custom designed skateboard moduls that can be designed to meet your needs. Combine banks quarter pipes and other elements. Contact us and we can put together a custom module for your project.

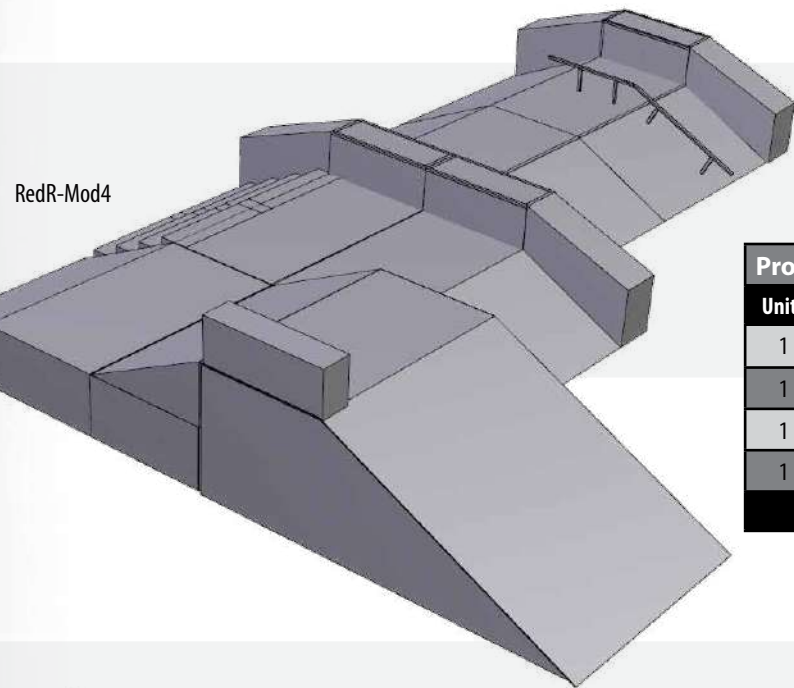

RedR-Mod4

Products Included		
Units	Product #	Description
1	RedR-Mod4	Module 4
1	RedR-BB102	Grind Ledge and Rail
1	RedR-BB103	Stairs and Grind Ledge
1	RedR-BB107	Grind Edge and Bank

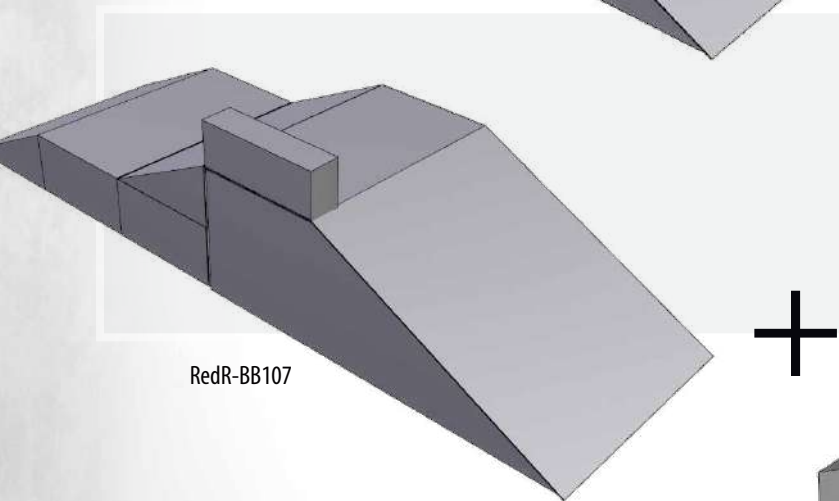

RedR-BB107

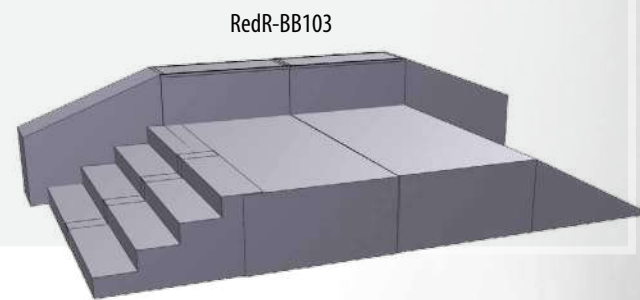

RedR-BB103

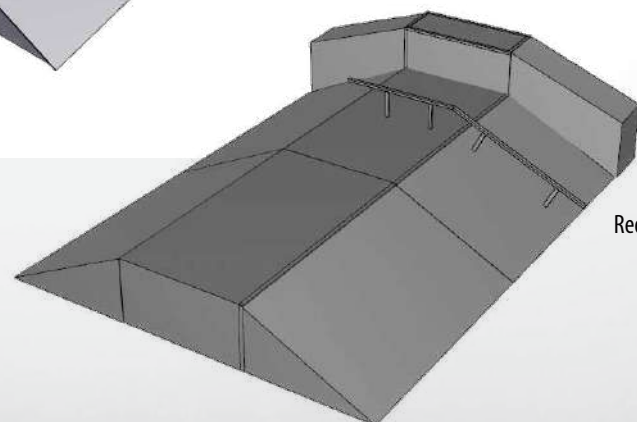

RedR-BB102

Pyramids

In order to keep the flow of a skate park, riders often need to be able to change direction. Pyramids can be modified with accessories such as grind rails, stairs and is a great way to keep riders challenged. The Pyramid can be placed at the perimeter of the skatepark or where needed to help keep a continuous flow from one obstacle to the next.

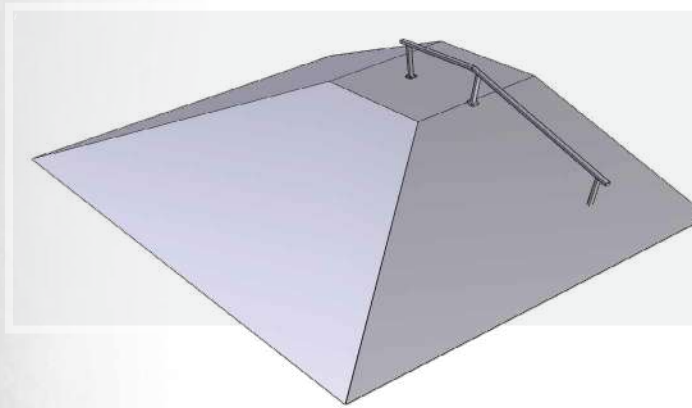

Product #	L	W	H	Features
RedR-PY101	18'	12'	2'	Grind Rail

Product #	L	W	H	Features
RedR-PY103	12'	18'	2'	Stairs and Grind Rail

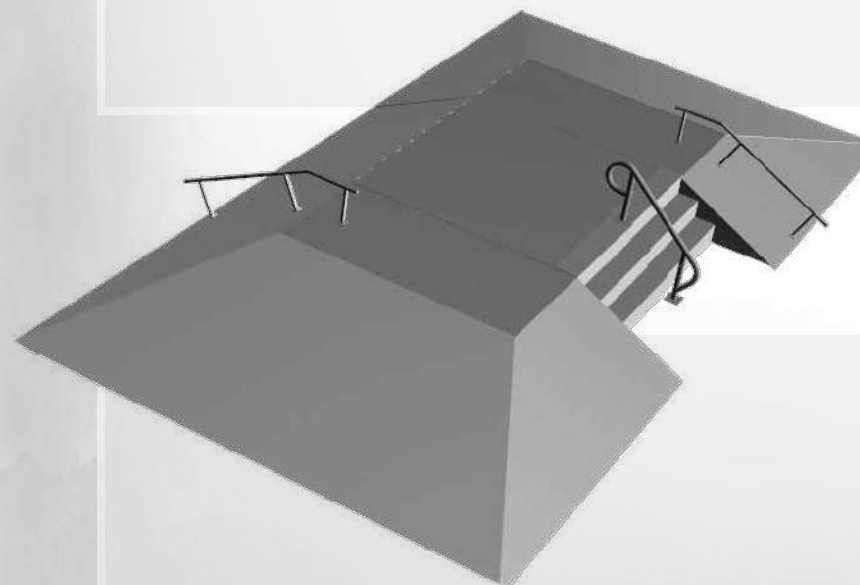
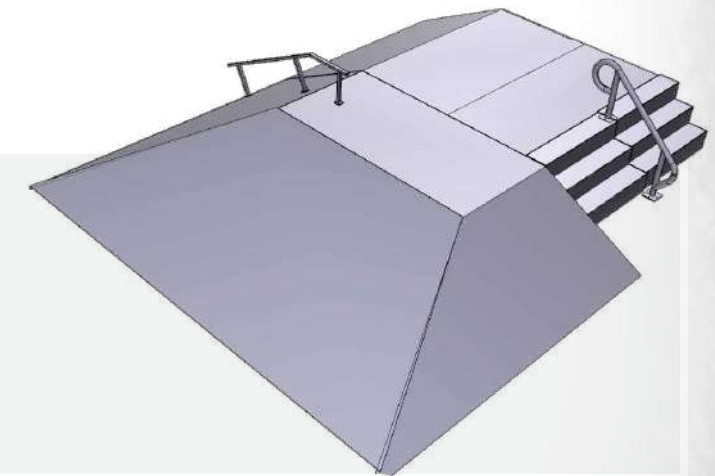

Product #	L	W	H	Features
RedR-PY102	20'	30'	2'	Stairs and Grind Rail

Grind Box / Manual Pad				
Product #	L	W	H	Features
RedR-GBox	12'	4'	1'	
Custom sizes are also available				

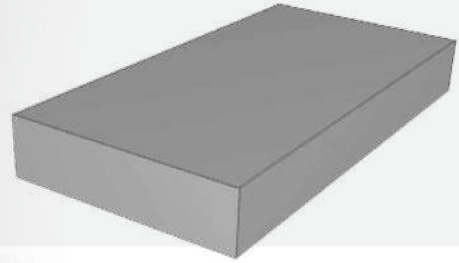

Launch Ramp				
Product #	L	W	H	Features
RedR-LRamp	6'	4'	2'	
Custom sizes are also available				

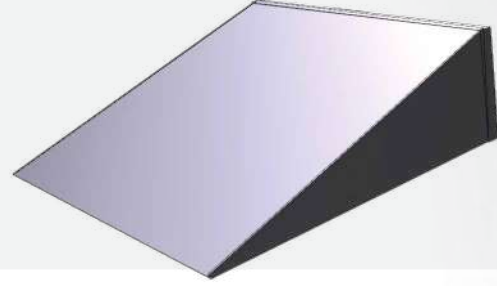

Mini Spine				
Product #	L	W	H	Features
RedR-SP100	10'	4'	2'	
Custom sizes are also available				

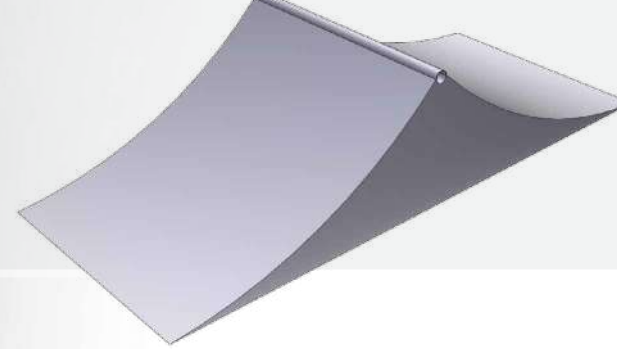

Spine				
Product #	L	W	H	Features
RedR-SP200	11'	7'-6"	4'	
Custom sizes are also available				

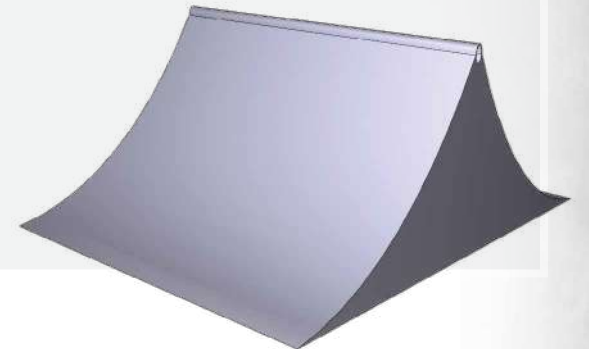

Grind Rail (Various Models)				
Product #	L	W	H	Features
RedR-GRail	10'	1'	1' <= 2'	Kinked
Custom sizes are also available				

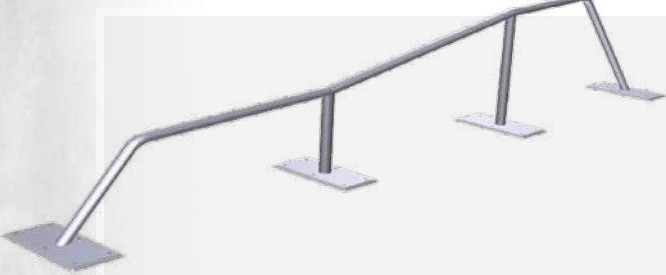

Skate Bench				
Product #	L	W	H	Features
RedR-SBench	8'	3'	1' <= 3'	
Custom sizes are also available				

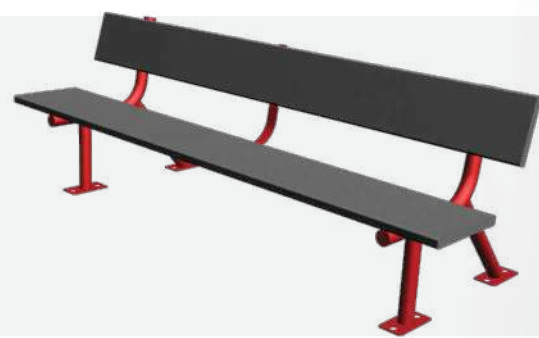

Camel Hump				
Product #	L	W	H	Features
RedR-CHump	10'-6"	4'	2'	
Custom sizes are also available				

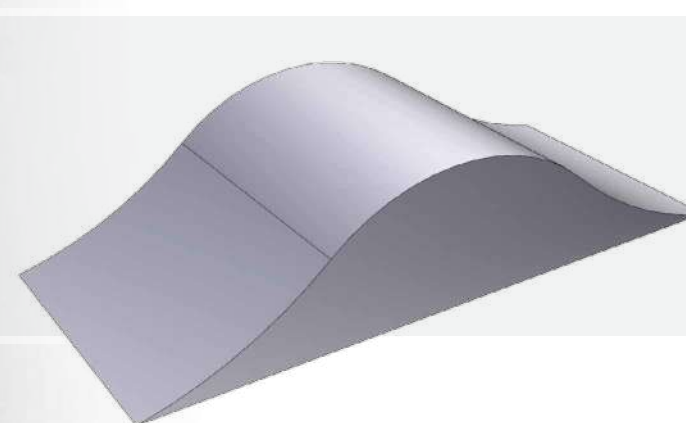

Corner Pyramid				
Product #	L	W	H	Features
RedR Corner	8'	7'	2'	
Custom sizes are also available				

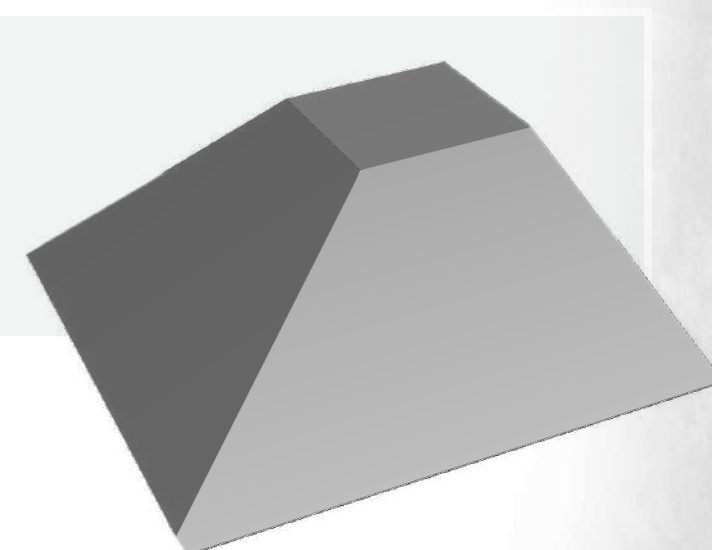

Skate Table				
Product #	L	W	H	Features
RedR-STable	8'	4'	2'	
Custom sizes are also available				



Barrier				
Product #	L	W	H	Features
Red R-Barrier	6'	2'	3'	
Custom sizes are also available				

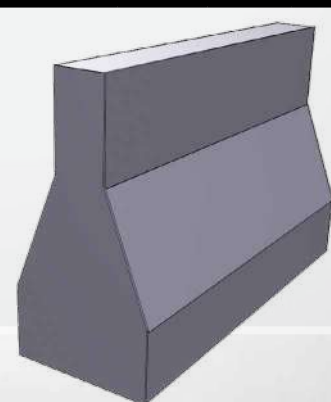

Ledge				
Product #	L	W	H	Features
RedR-Ledge	13'-6"	2'	2'	
Custom sizes are also available				

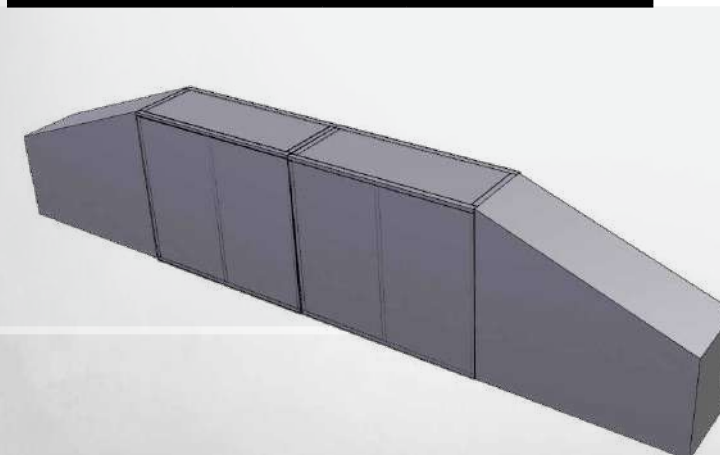

Park Model 1

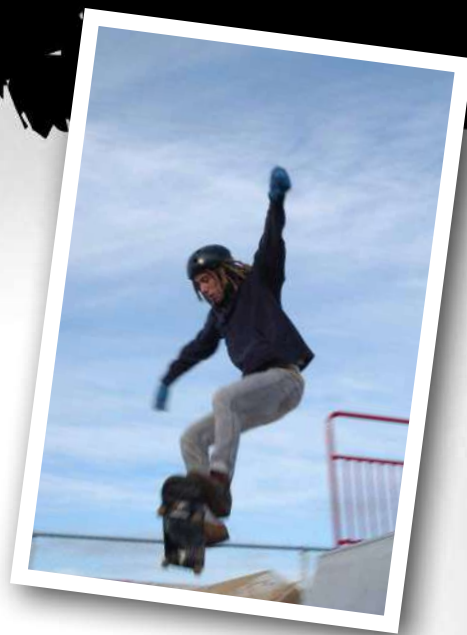

Park Model 2

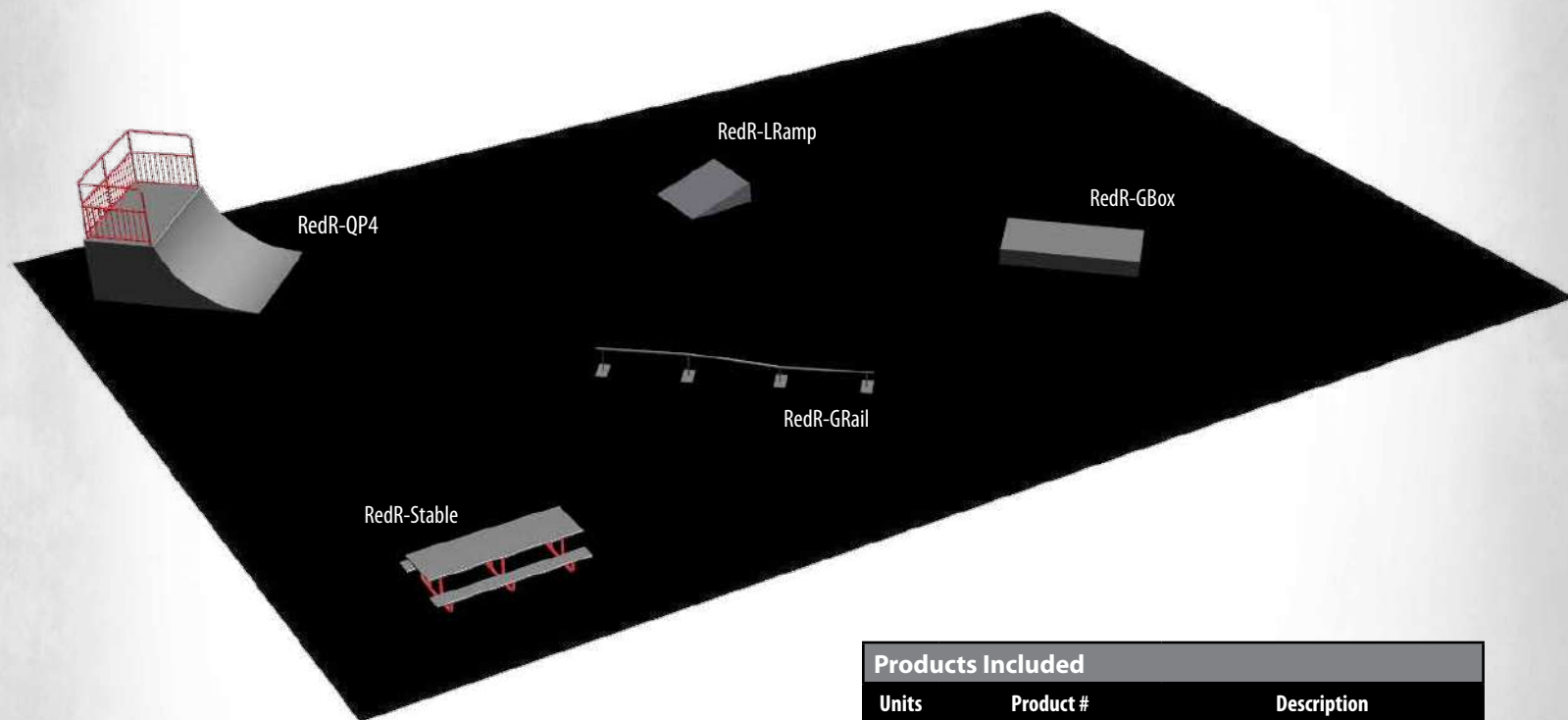

Products Included		
Units	Product #	Description
1	RedR-QP4	4' Quarter Pipe
1	RedR-Stable	Skate Table
1	RedR-LRamp	Launch Ramp
1	RedR-GRail	Grind Rail
1	RedR-GBox	Grind Box

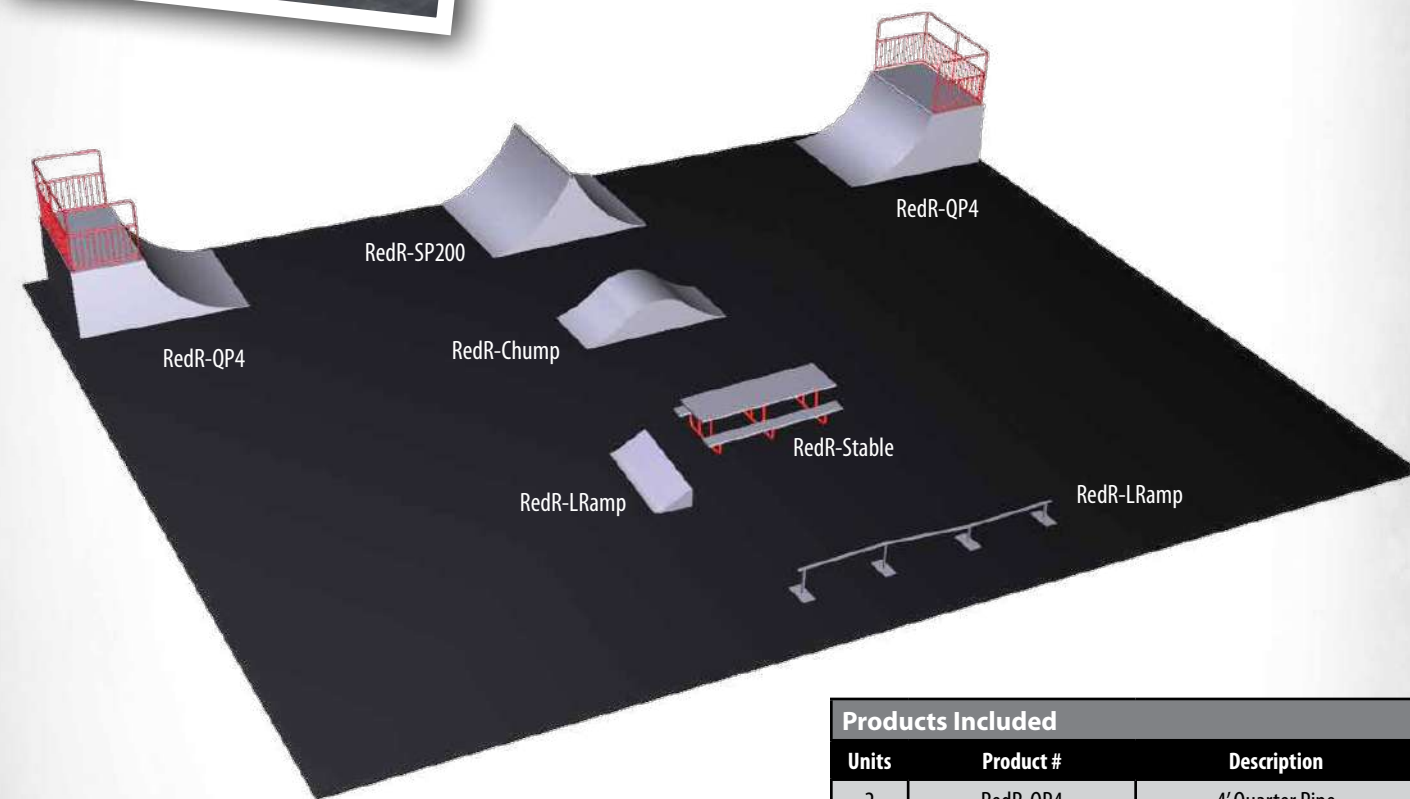

Products Included		
Units	Product #	Description
2	RedR-QP4	4' Quarter Pipe
1	RedR-SP200	4' Spine
1	RedR-Chump	Camel Hump
1	RedR-Grail	Grind Rail
1	RedR-Stable	Skate Table
1	RedR-LRamp	Launch Ramp

Park Model 3

Park Model 4

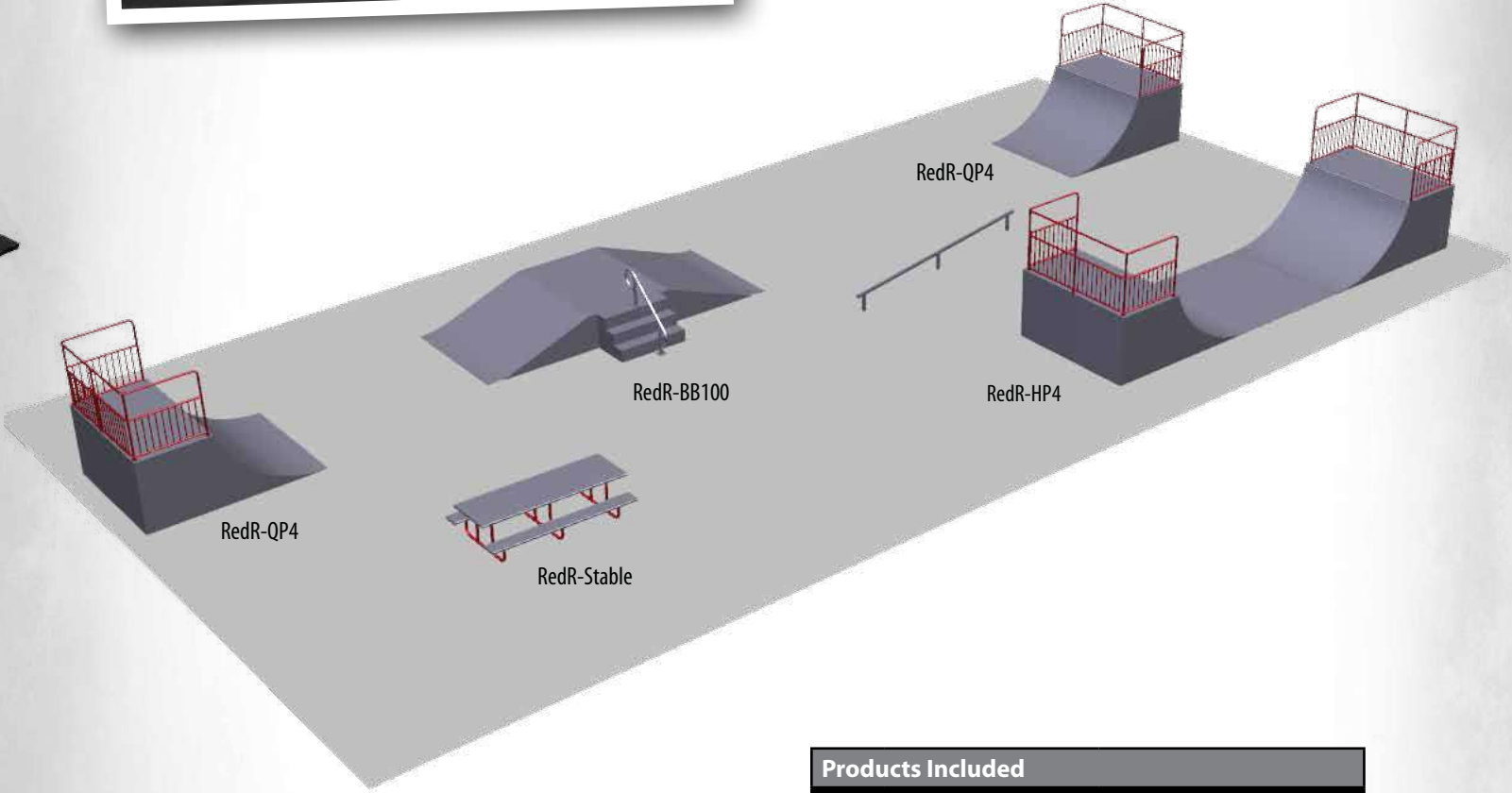
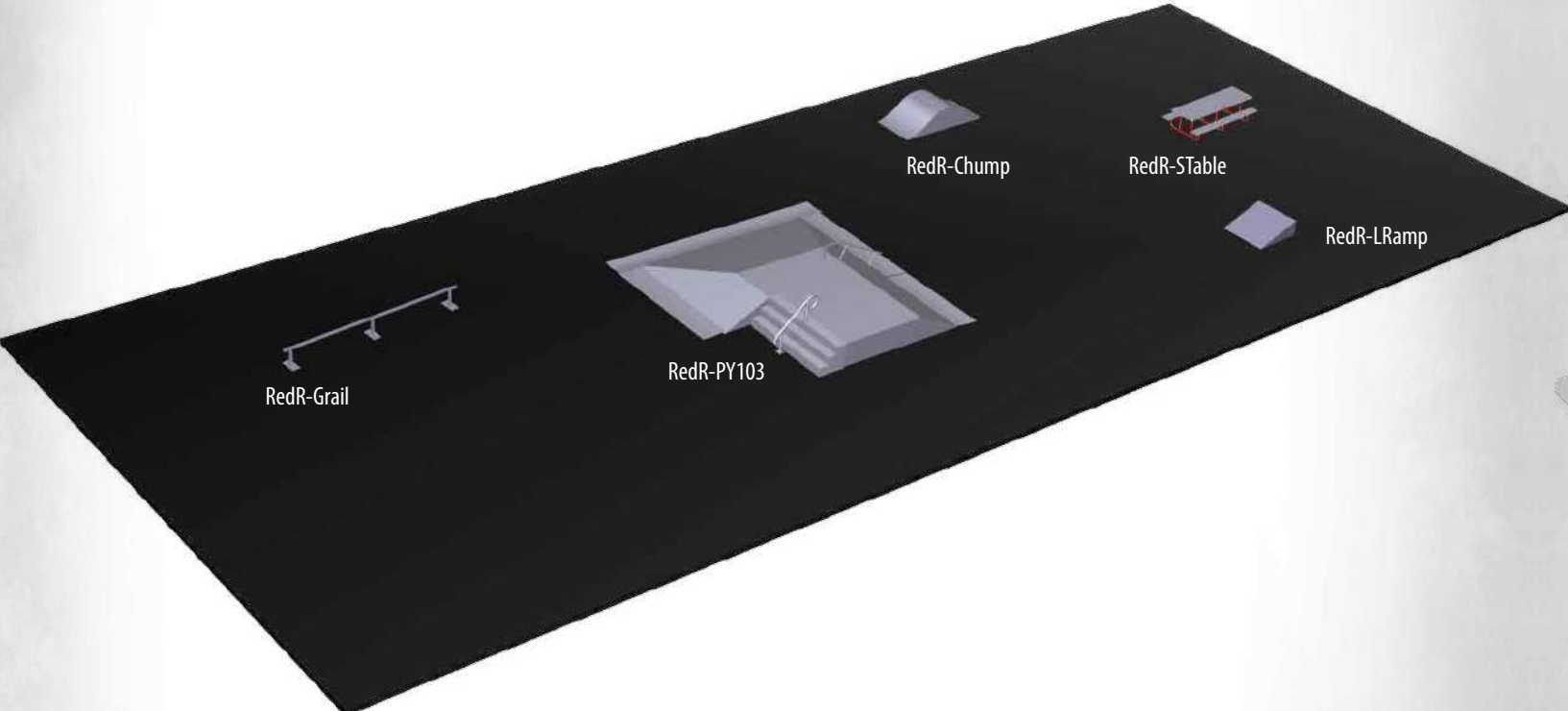

Products Included		
Units	Product #	Description
1	RedR-PY103	Pyramid with Stairs Bank and Rail
1	RedR-Grail	Grind Rail
1	RedR-LRamp	Launch Ramp
1	RedR-Chump	Camel Hump
1	RedR-STable	Skate Table

Products Included		
Units	Product #	Description
1	RedR-BB100	Bank to bank with stairs
2	RedR-QP4	4' Quarter Pipe
1	RedR-Stable	Skate Table
1	RedR-Grail	Grind Rail
1	RedR-HP4	4' Half Pipe

Park Model 5

Park Model 6

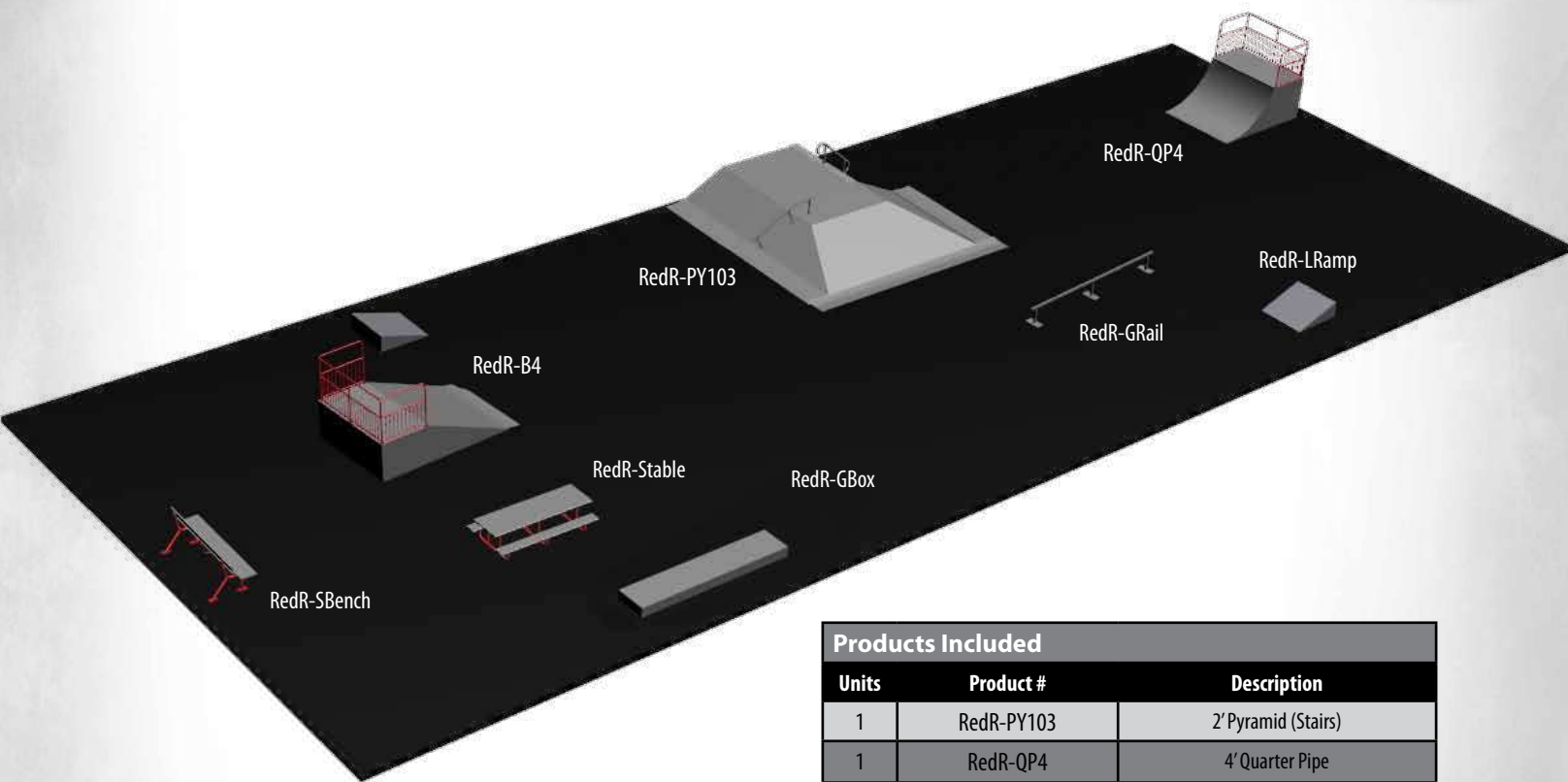

Products Included		
Units	Product #	Description
1	RedR-PY103	2' Pyramid (Stairs)
1	RedR-QP4	4' Quarter Pipe
1	RedR-B4	4' Bank
1	RedR-Stable	Skate Table
1	RedR-GRail	Grind Rail
1	RedR-GBox	Grind Box
1	RedR-LRamp	Launch Ramp
1	RedR-SBench	Skate Bench

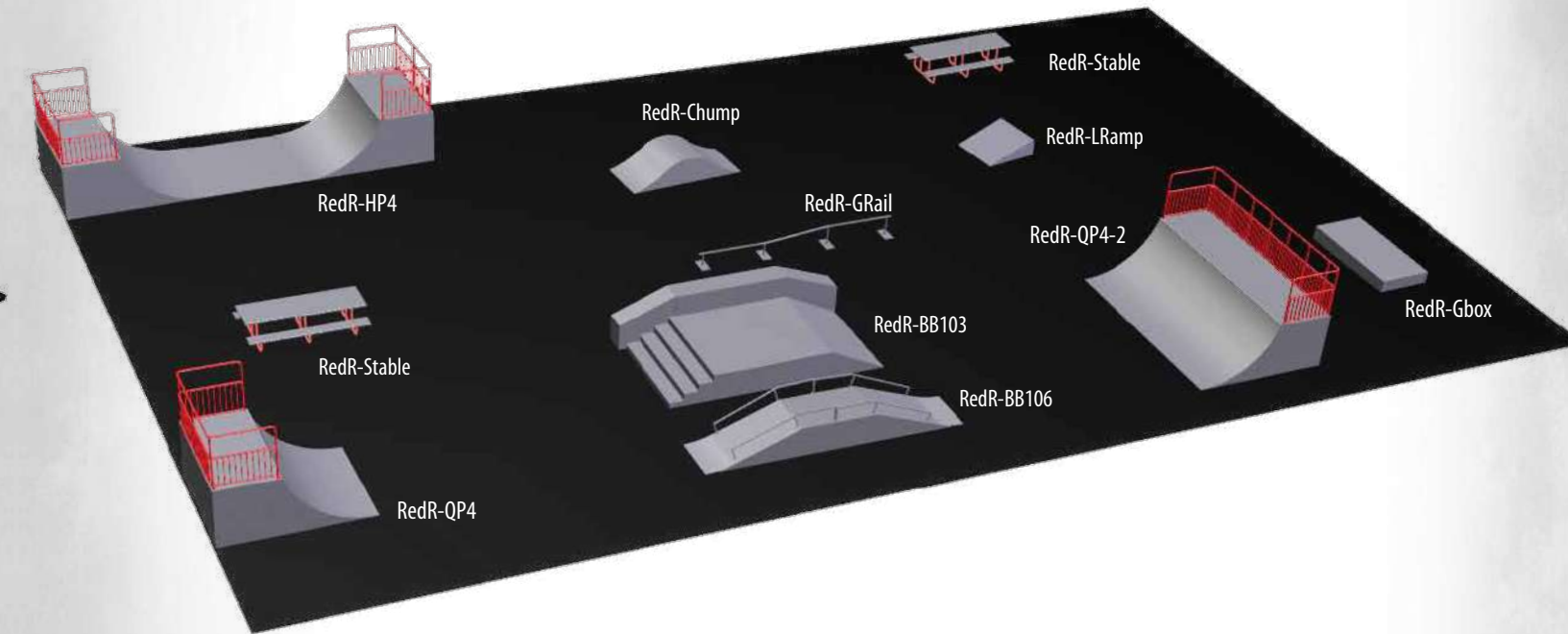

Products Included		
Units	Product #	Description
1	RedR-QP4	4' Quarter Pipe
1	RedR-QP4-2	4' Quarter Pipe
1	RedR-HP4	4' Half Pipe
1	RedR-GRail	Grind Rail
1	RedR-Gbox	Grind Box
1	RedR-Chump	Camel Hump
2	RedR-Stable	Skate Table
1	RedR-BB103	Bank with Stairs Grind ledge
1	RedR-BB106	Bank to Bank with Grind Rails
1	RedR-LRamp	Launch Ramp

Park Model 7

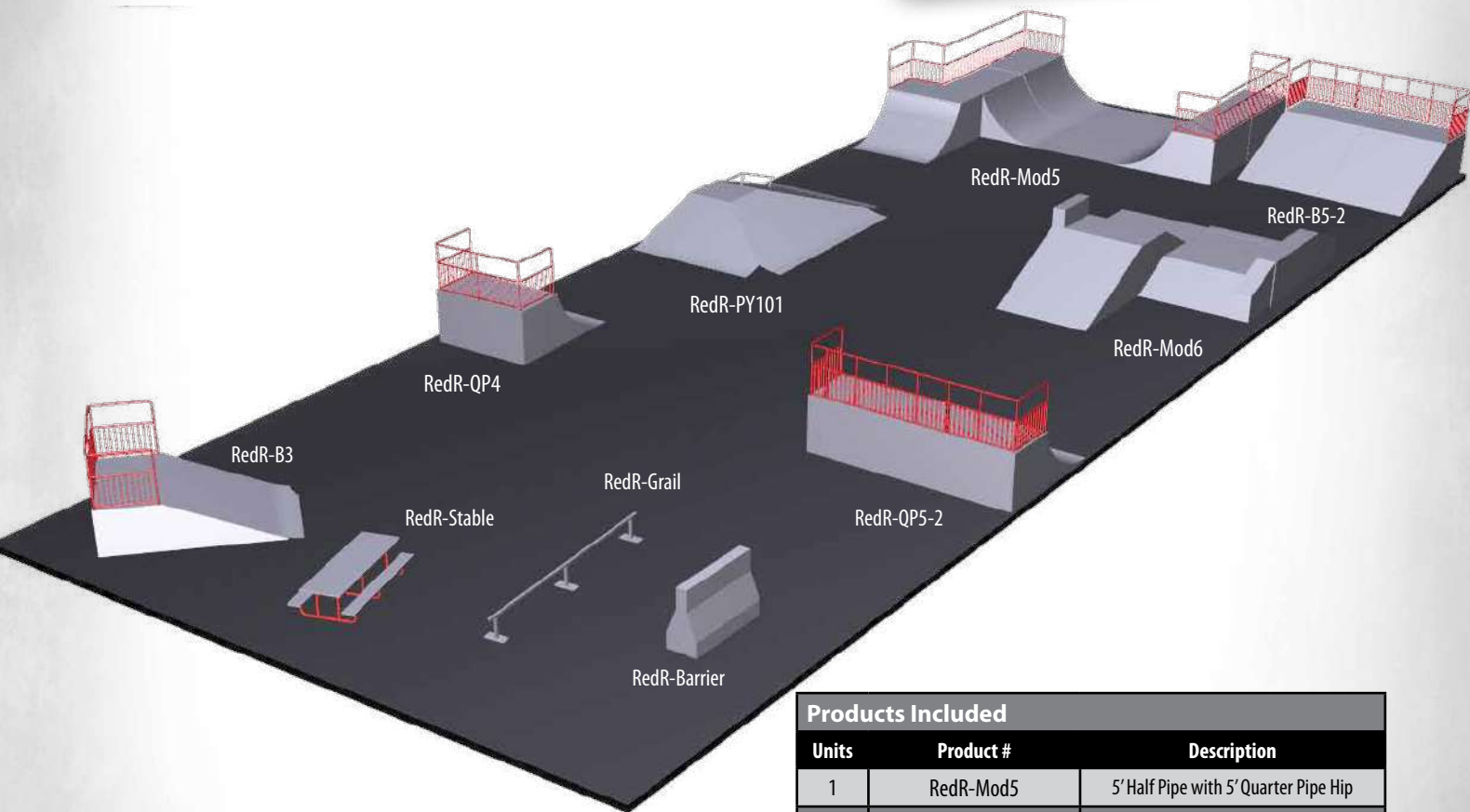

Products Included		
Units	Product #	Description
1	RedR-Mod5	5' Half Pipe with 5' Quarter Pipe Hip
1	RedR-PY101	2' Pyramid
1	RedR-QP4	4' Quarter Pipe
1	RedR-Stable	Skate Table
1	RedR-B5-2	5' Bank (2 X wide)
1	RedR-QP5-2	5' Quarter Pipe (2X Wide)
1	RedR-Mod6	Combination Bank Module
1	RedR-B3	3' Bank
1	RedR-Grail	Grind Rail
1	RedR-Barrier	Skate Barrier

Park Model 8

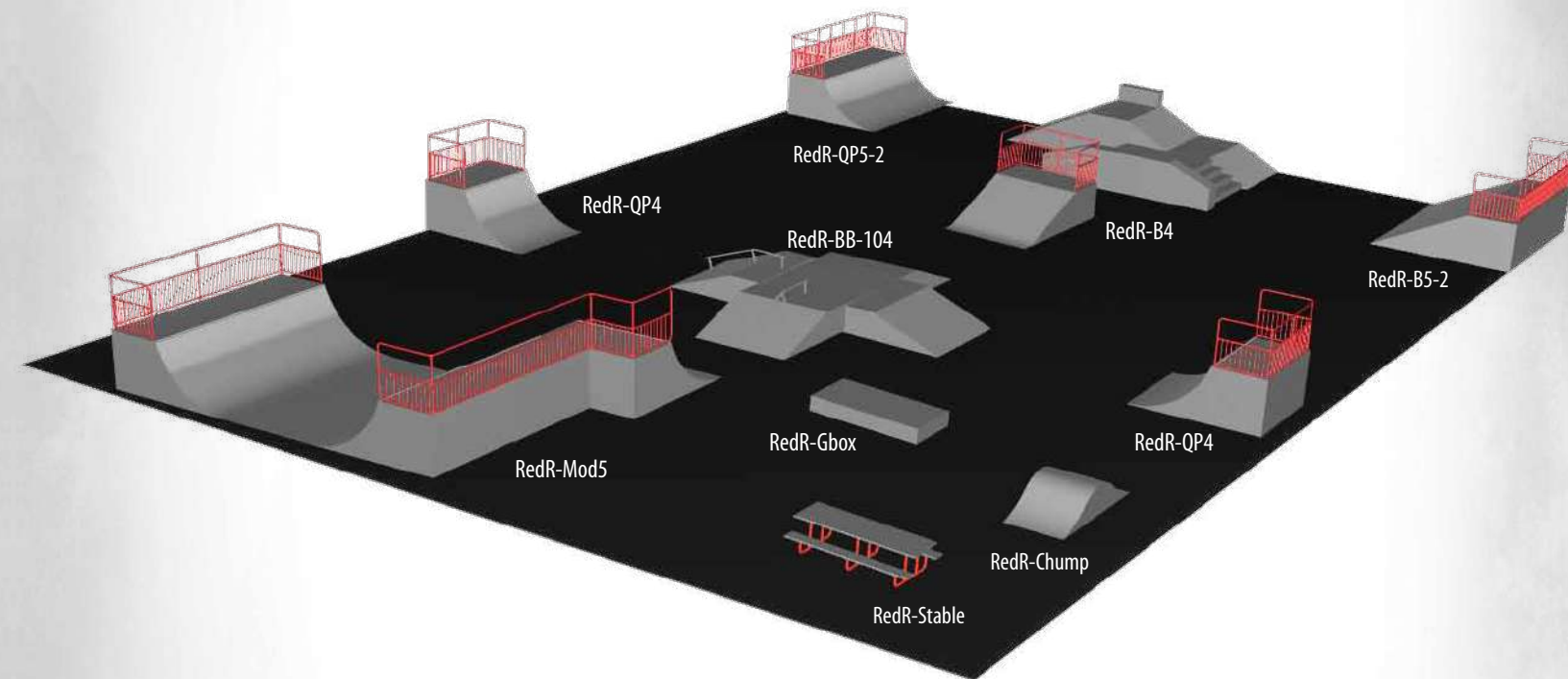

Products Included		
Units	Product #	Description
1	RedR-Mod5	5' Half Pipe with 5' Quarter Pipe Hip
1	RedR-BB104	4 way bank to bank with grind rail
2	RedR-QP4	4' Quarter Pipe
1	RedR-B4	4' Bank
1	RedR-Gbox	Grind Box
1	RedR-Chump	Camel Hump
1	RedR-Stable	Skate Table
1	RedR-B5-2	5' Bank (2 X wide)
1	RedR-QP5-2	5' Quarter Pipe (2 X wide)
1	RedR-Mod1001	Combination Bank Module

REDRAILED

SKATEBOARD RAMPS & ACCESSORIES



Toll Free: 1-(888) 212-1411
www.redrailed.com
Kan-Go-Roo Playgrounds Ltd.

23 Boom Lane Unit E
Atholville, NB E3N 4E8
Toll Free: 1 888 212-1411
Fax: 1 888 789-0987

